



Main

Range of product	Harmony K
Product or component type	Complete cam switch
Product mounting	In plastic enclosure
Component name	KA2
[I _{th}] conventional free air thermal current	16 A
Cam switch function	Emergency stop switch
Enclosure material	PVC
Cam switch head type	With front plate 60 x 60 mm
Type of operator	Red handle
Rotary handle padlocking	Without
Presentation of legend	With yellow legend, O-I black marking
Poles description	3P + N

Complementary

Presentation of legend holder	With metallic finish blank legend
Contacts operation	Make before break
Operational power in W	5500 W at 400 V AC-23
CAD overall width	74 mm
CAD overall height	135 mm
CAD overall depth	112 mm
Product weight	0.4 kg

The information provided in this documentation contains general descriptions and/or technical characteristics of the performance of the products contained herein. This documentation is not intended as a substitute for and is not to be used for determining suitability or reliability of these products for specific user applications. It is the duty of any such user or integrator to perform the appropriate and complete risk analysis, evaluation and testing of the products with respect to the relevant specific application or use thereof. Neither Schneider Electric Industries SAS nor any of its affiliates or subsidiaries shall be responsible or liable for misuse of the information contained herein.

Cam Switch in Plastic Enclosure

Dimensions and Mounting

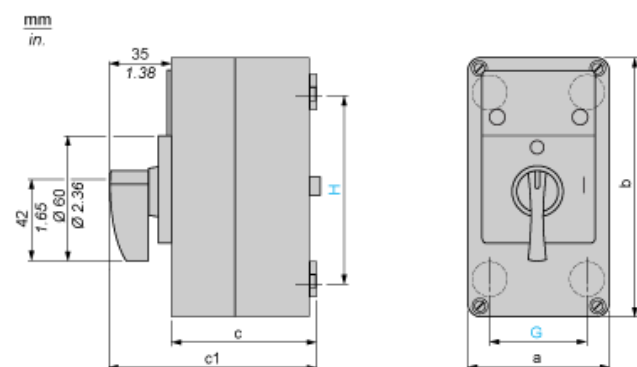

- a 74 mm/2.91 in.
- b 135 mm/5.31 in.
- c 72 mm/2.83 in.
- c1 106 mm/4.17 in.
- G 50 mm/1.97 in.
- H 95 mm/3.74 in.

1 entry for n°16 cable gland at the top and at the bottom.