



### Main

Range of product	Harmony XALF
Product or component type	Hoistway box
Device short name	XALF
Product specific application	Lift inspection
Operator profile	1 illuminated mushroom head pushbutton
Operator description	Red unmarked 1 NO + 1 NC
Contacts operation	Slow-break

### Complementary

Material	Polycarbonate
Product weight	0.185 kg
Marking	CE
Contacts material	Silver alloy (Ag/Ni)
Light source colour	White

### Environment

Protective treatment	TH
Ambient air temperature for storage	-40...70 °C
Ambient air temperature for operation	0...50 °C
Standards	EN 81-1 EN/IEC 60947-1 EN/IEC 60947-5-1 EN/IEC 60947-5-4 EN/IEC 60947-5-5

Dimensions

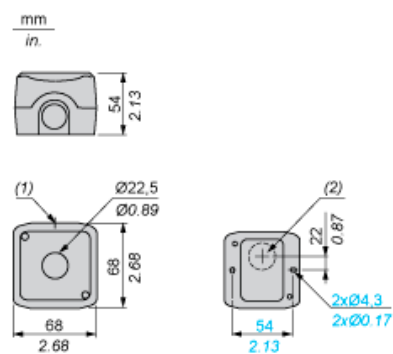

- (1) 2 knock-outs for Pg 13.5 cable gland, maximum capacity 12 mm / 0.47 in.  
(2) Knock-out for cable entry, maximum capacity 14 mm / 0.55 in.