

**MOSA M12 FEMALE 90° 3LED FIELD-WIREABLE (IDC)**4-pol. 0.25...0.5mm<sup>2</sup>

Female 90°

M12, 4-pole

3× LED (PNP)

IDC terminals

Connection cross section: 0.25...0.5 mm<sup>2</sup>

Art-No. 7005 - M12 Lite - (plastic hexagonal screw) on request

The resistance to aggressive media should be individually tested for your application. Further details on request.

[Link to Product](#)**Illustration**

Female

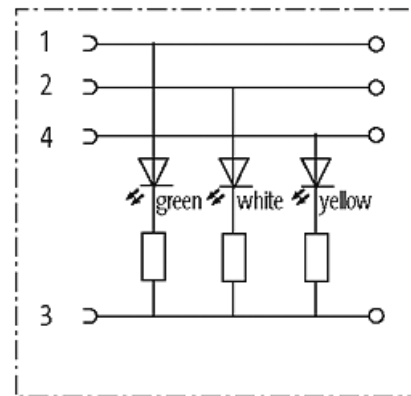
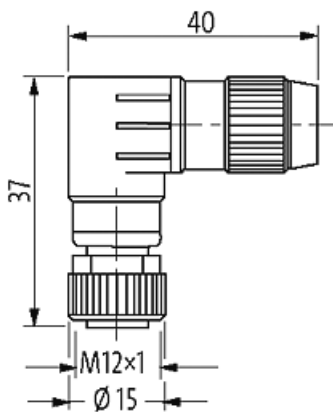
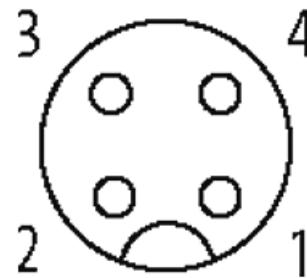

Product may differ from Image

**Form**

Form 12691

**Technical Data**

Operating voltage	24 V DC ±25%
Operating current per contact	max. 4 A
Connection cross section	0.25...0.5 mm <sup>2</sup> (conductor diameter min. 0.1 mm)
Sealing range (cable Ø)	4...5.1 mm
Wire isolation	PVC, PP, TPE
Outer wire Ø	1.2...1.6 mm
Locking of ports	Screw thread (M12×1 mm) recommended torque 0.6 Nm, self-securing
Protection	IP67 inserted and tightened (EN 60529)

Reconnection (cable)	10
----------------------	----

**General data**

Temperature range	-25...+85 °C
Dimensions H×W×D	37×40×15 mm

**Commercial data**

country of origin	DE
customs tariff number	85366990
EAN	4048879201674
eClass	27279221
Packaging unit	1