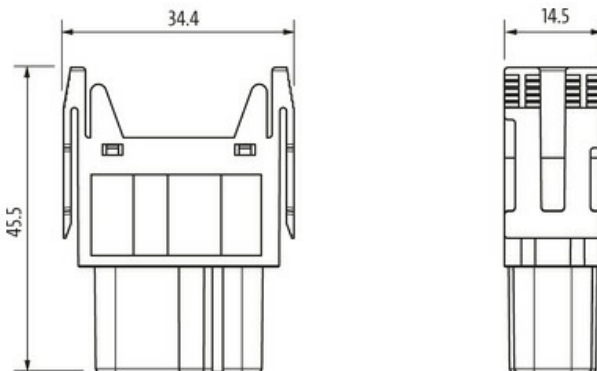
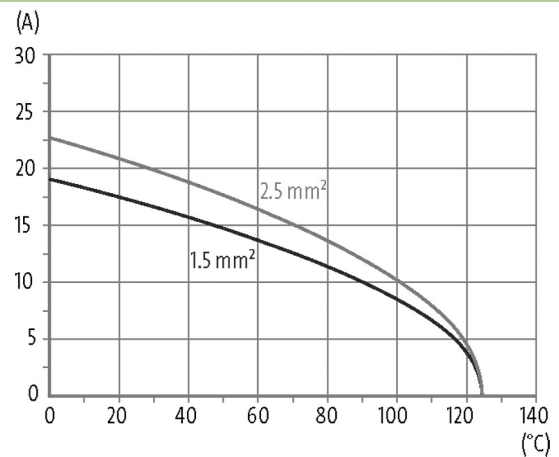

**Female module, 8-pole, crimp t.**

400 V, 16 A

Female  
8-pole  
Crimp

Technical data will be only guaranteed with Murrelektronik components.

**Link to Product****Illustration**

Product may differ from Image

**Technical Data**

Operating voltage	400 V AC/DC
Rated surge voltage	6.0 kV
Operating current	16 A
No. of poles	8
Material group	I
Mating cycles	min. 500
Connection	Crimp
Connection cross section	0.5...4 mm <sup>2</sup> (AWG 20...11)
Holding force (contacts)	≥ 130 N
Insertion and withdrawal force	< 220 N
Isolation resistance	≥ 10 <sup>8</sup> Ω
Contact resistance	≤ 5 mΩ
Over voltage category	III

Wire-Ø incl. isolation	max. 4.6 mm
Holding force (modules)	≥ 300 N

#### General data

Material (contact)	Brass
Material (contact surface)	Ag Au
Pollution Degree	3
Temperature range	-40...+125 °C
No. of module positions	1
Flammability class	V-0 (acc. to UL 94)
Type	Female
Climatic category	40/125/10
Material (module)	PA GF
Dimensions H×W×D	45.5×14.5×34.4 mm

#### Cables

Current load capacity	see derating curve
-----------------------	--------------------

#### Commercial data

country of origin	CZ
customs tariff number	85389099
EAN	4048879641630
eClass	27143424
Packaging unit	5.000