

ILE2P661PC1A1

brushless dc motor 24..48 V - Ethernet
Powerlink interface - L = 174 mm - 18:1



Main

Range of product	Lexium integrated drive
Product or component type	Motion integrated drive
Device short name	ILE
Motor type	Brushless dc motor
Number of motor poles	6
Network number of phases	Single phase
[Us] rated supply voltage	24 V 48 V
Network type	DC
Communication interface	Integrated Ethernet Powerlink
Length	174 mm
Winding type	Medium speed of rotation and medium torque
Electrical connection	Industrial connector
Holding brake	Without
Gear box type	Straight teeth gear, 3 stages
Reduction ratio	18:1 (160:9)
Nominal speed	281 rpm at 48 V 225 rpm at 24 V
Nominal torque	3.5 N.m at 48 V 3.5 N.m at 24 V

Complementary

Transmission rate	100 Mbits
Mounting support	Flange
Motor flange size	66 mm
Number of motor stacks	1
Centring collar diameter	16 mm
Centring collar depth	4 mm
Number of mounting holes	4
Mounting holes diameter	4.4 mm
Circle diameter of the mounting holes	73.54 mm
Feedback type	BLDC encoder
Shaft end	Keyed
Second shaft	Without second shaft end
Shaft diameter	10 mm
Shaft length	25 mm
Key width	16 mm
Supply voltage limits	18...55.2 V
Current consumption	5500 mA (maximum continuous) 7000 mA (peak)
Associated fuse rating	16 A
Commissioning interface	RS485 Modbus TCP (9.6, 19.2 and 38.4 kbauds)
Input/Output type	4 signals (each be used as input or output)
Voltage state 0 guaranteed	-3...4.5 V
Voltage state 1 guaranteed	15...30 V

Discrete input current	2 mA at 24 V for 24 V signal interface <= 3 mA at 24 V on/STO_B for safety input <= 10 mA at 24 V on/STO_A for safety input
Discrete output voltage	23...25 V
Maximum switching current	200 mA total 100 mA per output
Protection type	Overload of output voltage Safe torque off Short circuit of the output voltage
Supply current	Supply: 3.8 A, 48 V Supply: 6.8 A, 24 V Supply: 0.1 A, power stage disabled
Nominal output power	95 W at 24 V 119 W at 48 V
Peak stall torque	6.19 N.m at 48 V 6.19 N.m at 24 V
Continuous stall torque	4.3 N.m
Detent torque	1.42 N.m
Speed feedback resolution	12 points/turn (motor) 1.667° (gearbox output)
Accuracy error	+/- 0.5 point
Torsional backlash	<= 1 °
Rotor inertia	48 kg.cm ²
Maximum mechanical speed	281 rpm
Maximum radial force Fr	200 N (short-term operation) 200 N (long-term operation)
Maximum axial force Fa	80 N (short-term operation) 10 N (long-term operation)
Service life in hours	15000 h of bearing : (long-term operation) 2500 h of bearing : (short-term operation)
Marking	CE
Type of cooling	Natural convection
Product weight	1.85 kg

Environment

Standards	EN 50347 EN 61800-3:2001, second environment EN 61800-3 : 2001-02 EN/IEC 50178 EN/IEC 61800-3 IEC 60072-1 IEC 61800-3, Ed 2
Product certifications	CUL TÜV UL
Ambient air temperature for operation	0...40 °C without derating > 40...55 °C with power derating of 2 % per °C
Permissible ambient air temperature around the device	110 °C (motor) 105 °C (power amplifier)
Ambient air temperature for storage	-25...70 °C
Operating altitude	<= 1000 m without derating
Relative humidity	15...85 % without condensation
Vibration resistance	20 m/s ² (f = 10...500 Hz) for 10 cycles conforming to EN/IEC 60068-2-6
Shock resistance	150 m/s ² for 1000 shocks conforming to EN/IEC 60068-2-29
IP degree of protection	IP54 total except shaft bushing conforming to EN/IEC 60034-5 IP41 shaft bushing conforming to EN/IEC 60034-5

Offer Sustainability

Sustainable offer status	Not Green Premium product
RoHS (date code: YYWW)	Compliant - since 0910 - Schneider Electric declaration of conformity
REACH	Reference not containing SVHC above the threshold

Integrated Drive with Straight Teeth Gear

Dimensions

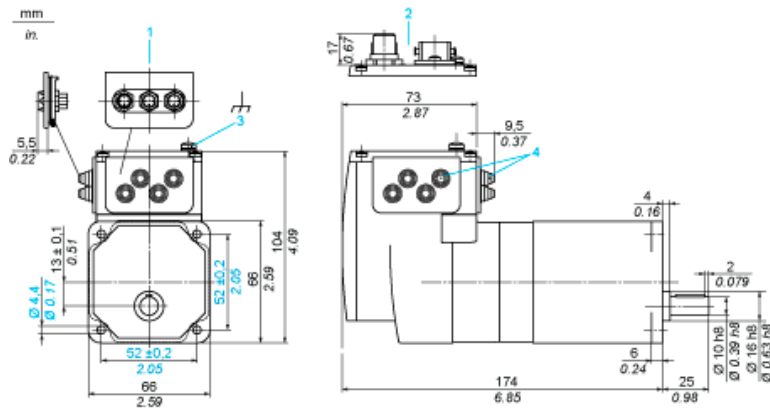

- 1 Accessories: I/O signal insert with industrial connectors
- 2 Option: industrial connectors
- 3 Earth (ground) terminal
- 4 Accessories: cable entries $\varnothing = 3 \dots 9 \text{ mm}/0.12 \dots 0.35 \text{ in.}$

Connection Example with 4 I/O Signals



Torque Characteristics

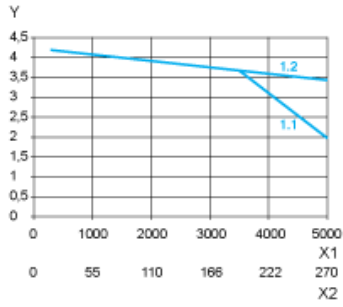

- X1 Speed of rotation of motor in rpm
- X2 Speed of rotation of gearing in rpm
- Y Torque in Nm
- 1.1 Max. torque at 24 V
- 1.2 Max. torque at 36 V