

ILS1V571PB1A0

integrated drive ILS with stepper motor-
24..36V-pulse/direction w/o RS422- 3.5A



Main

Range of product	Lexium integrated drive
Product or component type	Motion integrated drive
Device short name	ILS
Motor type	3-phase stepper motor
Number of motor poles	6
Network number of phases	Single phase
[Us] rated supply voltage	24 V 36 V
Network type	DC
Communication interface	Integrated pulse/direction 5 V without RS422
Length	101.9 mm
Winding type	Medium speed of rotation and medium torque
Electrical connection	Printed circuit board connector
Holding brake	Without
Gear box type	Without
Nominal speed	500 rpm at 24 V 1000 rpm at 36 V
Nominal torque	0.45 N.m
Holding torque	0.51 N.m

Complementary

Mounting support	Flange
Motor flange size	57 mm
Number of motor stacks	1
Centring collar diameter	38.1 mm
Centring collar depth	1.6 mm
Number of mounting holes	4
Mounting holes diameter	5.2 mm
Circle diameter of the mounting holes	66.6 mm
Feedback type	Index pulse
Shaft end	Untapped
Second shaft	Without second shaft end
Shaft diameter	6.35 mm
Shaft length	21 mm
Supply voltage limits	18...40 V
Current consumption	3500 mA (maximum continuous)
Associated fuse rating	10 A
Input/Output type	4 signals (each be used as input or output)
Voltage state 0 guaranteed	-3...4.5 V
Voltage state 1 guaranteed	15...30 V
Discrete input current	10 mA at 24 V for safety input
Discrete output voltage	23...25 V
Maximum switching current	200 mA total 100 mA per output
Protection type	Overload of output voltage Safe torque off Short circuit of the output voltage

Peak stall torque	0.45 N.m
Continuous stall torque	0.45 N.m
Speed feedback resolution	200, 400, 500, 1000, 2000, 4000, 5000, 10000 steps 1.8°, 0.9°, 0.72°, 0.36°, 0.18°, 0.09°, 0.072°, 0.036°
Accuracy error	+/- 6 arc min
Rotor inertia	0.1 kg.cm ²
Maximum mechanical speed	3000 rpm
Maximum radial force Fr	24 N
Maximum axial force Fa	8.4 N (force pressure) 100 N (tensile force)
Service life in hours	20000 h of bearing :
Marking	CE
Type of cooling	Natural convection
Product weight	1.3 kg

Environment

Standards	EN 50347 EN 61800-3:2001, second environment EN 61800-3 : 2001-02 EN/IEC 50178 EN/IEC 61800-3 IEC 60072-1 IEC 61800-3, Ed 2
Product certifications	CUL TÜV UL
Ambient air temperature for operation	0...50 °C without derating > 50...65 °C with power derating of 2 % per °C
Permissible ambient air temperature around the device	110 °C (motor) 105 °C (power amplifier)
Ambient air temperature for storage	-25...70 °C
Operating altitude	<= 1000 m without derating
Relative humidity	15...85 % without condensation
Vibration resistance	20 m/s ² (f = 10...500 Hz) for 10 cycles conforming to EN/IEC 60068-2-6
Shock resistance	150 m/s ² for 1000 shocks conforming to EN/IEC 60068-2-29
IP degree of protection	IP54 total except shaft bushing conforming to EN/IEC 60034-5 IP41 shaft bushing conforming to EN/IEC 60034-5

Offer Sustainability

Sustainable offer status	Not Green Premium product
RoHS (date code: YYWW)	Compliant - since 0922 - Schneider Electric declaration of conformity
REACH	Reference not containing SVHC above the threshold
Product environmental profile	Available Download Product Environmental

Integrated Drive

Dimensions

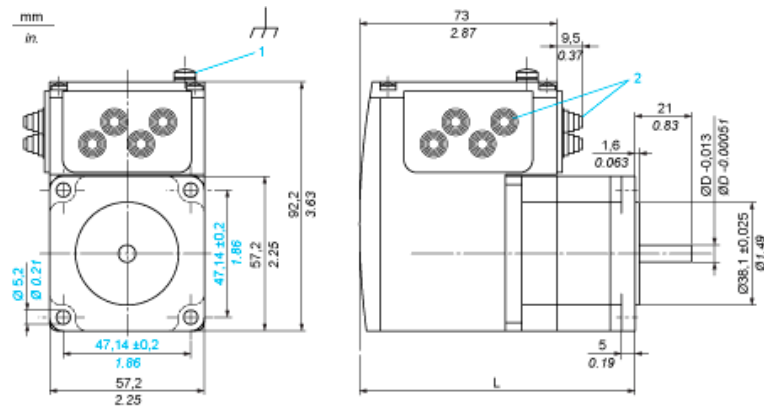

- 1 Earth (ground) terminal
- 2 Accessories: cable entries $\varnothing = 3 \dots 9 \text{ mm} / 0.12 \dots 0.35 \text{ in.}$
- L 101.9 mm/4.01 in.
- D 6.35 mm/0.25 in.

Multifunction Interface

Input Wiring Diagram

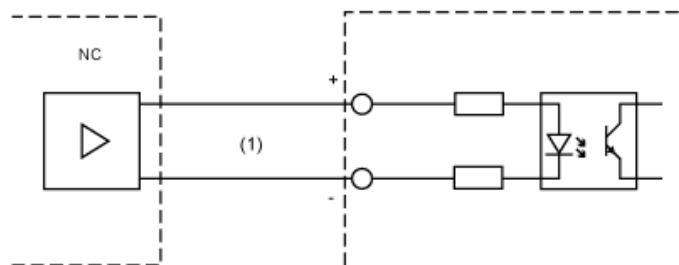

(1) Opto-isolated signals

The reference pulses are supplied via two of the signal inputs, either as pulse/ direction signals or as A/B signals. The other signal inputs have the functions "power amplifier enable/pulse blocking" and "step size switching/PWM motor current control".

Torque Characteristics

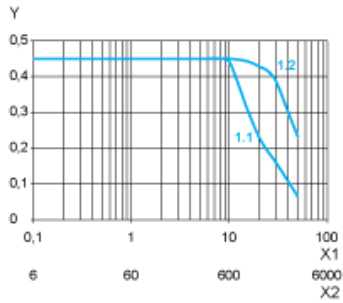

- X1 Frequency in kHz
- X2 Speed of rotation in rpm
- Y Torque in Nm
- 1.1 Max. torque at 24 V
- 1.2 Max. torque at 36 V