

# ATV650U40N4

variable speed drive ATV650 - 4kW/5HP -  
380...480V - IP55



## Main

Range of product	Altivar Process ATV600
Product or component type	Variable speed drive
Product specific application	Process and utilities
Device short name	ATV650
Variant	Standard version
Product destination	Asynchronous motors Synchronous motors
Mounting mode	Wall mount
EMC filter	Integrated conforming to EN/IEC 61800-3 category C2 with 50 m motor cable maxi Integrated conforming to EN/IEC 61800-3 category C3 with 150 m motor cable maxi
IP degree of protection	IP55 conforming to IEC 61800-5-1 IP55 conforming to IEC 60529
Type of cooling	Forced convection
Supply frequency	50...60 Hz (- 5...5 %)
Network number of phases	3 phases
[Us] rated supply voltage	380...480 V (- 15...10 %)
Motor power kW	4 kW (normal duty) 3 kW (heavy duty)
Motor power hp	5 hp (normal duty)
Line current	7.6 A at 380 V (normal duty) 6.7 A at 480 V (normal duty) 6 A at 380 V (heavy duty) 5.4 A at 480 V (heavy duty)
Prospective line I <sub>sc</sub>	50 kA
Apparent power	5.6 kVA at 480 V (normal duty) 4.5 kVA at 480 V (heavy duty)
Continuous output current	9.3 A at 4 kHz (normal duty) 7.2 A at 4 kHz (heavy duty)
Maximum transient current	10.8 A during 60 s (heavy duty) 10.2 A during 60 s (normal duty)
Asynchronous motor control profile	Constant torque standard Variable torque standard Optimized torque mode
Synchronous motor control profile	Permanent magnet motor
Speed drive output frequency	0.1...500 Hz
Nominal switching frequency	4 kHz
Switching frequency	2...12 kHz adjustable 4...12 kHz with derating factor
Safety function	STO (safe torque off) SIL 3
Number of preset speeds	16 preset speeds

The information provided in this documentation contains general descriptions and/or technical characteristics of the performance of the products contained herein. This documentation is not intended as a substitute for and is not to be used for determining suitability or reliability of these products for specific user applications. It is the duty of any such user or integrator to perform the appropriate and complete risk analysis, evaluation and testing of the products with respect to the relevant specific application or use thereof. Neither Schneider Electric Industries SAS nor any of its affiliates or subsidiaries shall be responsible or liable for misuse of the information contained herein.

Communication port protocol	Ethernet Modbus serial Modbus TCP
Option card	Slot A : communication module for Profibus DP V1 Slot A : communication module for Profinet Slot A : communication module for DeviceNet Slot A : communication module for Modbus TCP/ EtherNet/IP Slot A : communication module for CANopen daisy chain RJ45 Slot A : communication module for CANopen SUB-D 9 Slot A : communication module for CANopen screw terminals Slot A/slot B : digital and analog I/O extension module Slot A/slot B : output relay extension module Slot A : communication module for Ethernet IP/Modbus TCP/MD-Link

## Complementary

Output voltage	$\leq$ power supply voltage
Permissible temporary current boost	1.1 x I <sub>n</sub> for 60 s (normal duty) 1.5 x I <sub>n</sub> for 60 s (heavy duty)
Motor slip compensation	Adjustable Automatic whatever the load Can be suppressed Not available in permanent magnet motor law
Acceleration and deceleration ramps	Linear adjustable separately from 0.01 to 9000 s S, U or customized
Braking to standstill	By DC injection
Protection type	Motor : thermal protection Motor : safe torque off Motor : motor phase break Drive : thermal protection Drive : safe torque off Drive : overheating Drive : overcurrent between output phases and earth Drive : overload of output voltage Drive : short-circuit protection Drive : motor phase break Drive : overvoltages on the DC bus Drive : line supply overvoltage Drive : line supply undervoltage Drive : line supply phase loss Drive : overspeed Drive : break on the control circuit
Frequency resolution	Display unit : 0.1 Hz Analog input : 0.012/50 Hz
Electrical connection	Control : removable screw terminals 0.5...1.5 mm <sup>2</sup> (AWG 20...AWG 16) Line side : screw terminal 4...6 mm <sup>2</sup> (AWG 12...AWG10) Motor : screw terminal 4...6 mm <sup>2</sup> (AWG 12...AWG10)
Type of connector	RJ45 (on the remote graphic terminal) for Ethernet/Modbus TCP RJ45 (on the remote graphic terminal) for Modbus serial
Physical interface	2-wire RS 485 for Modbus serial
Transmission frame	RTU for Modbus serial
Transmission rate	10/100 Mbit/s for Ethernet IP/Modbus TCP 4.8, 9.6, 19.2, 38.4 kbit/s for Modbus serial
Exchange mode	Half duplex, full duplex, autonegotiation for Ethernet/Modbus TCP
Data format	8 bits, configurable odd, even or no parity for Modbus serial
Type of polarization	No impedance for Modbus serial
Number of addresses	1...247 for Modbus serial
Method of access	Slave for Modbus TCP
Supply	External supply for digital inputs : 24 V DC (19...30 V) current $\leq$ 1.25 mA (overload and short-circuit protection) Internal supply for reference potentiometer (1 to 10 kOhm) : 10.5 V DC +/- 5 % current $\leq$ 10 mA (overload and short-circuit protection) Internal supply for digital inputs and STO : 24 V DC (21...27 V) current $\leq$ 200 mA (overload and short-circuit protection)

Local signalling	3 LEDs for local diagnostic 3 LEDs dual colour for embedded communication status 4 LEDs dual colour for communication module status 1 LED red for presence of voltage
Width	264 mm
Height	678 mm
Depth	272 mm
Product weight	10.6 kg
Analogue input number	3
Analogue input type	Software-configurable voltage AI1, AI2, AI3 : 0...10 V DC impedance 30 kOhm, resolution 12 bits Software-configurable current AI1, AI2, AI3 : 0...20 mA impedance 250 Ohm, resolution 12 bits
Discrete input number	8
Discrete input type	Programmable DI1...DI6 : 24 V DC $\leq$ 30 V impedance 3.5 kOhm Programmable as pulse input DI5, DI6 0...30 kHz : 24 V DC $\leq$ 30 V Safe torque off STOA, STOB : 24 V DC $\leq$ 30 V impedance $>$ 2.2 kOhm
Input compatibility	Discrete input DI1...DI6 : level 1 PLC conforming to EN/IEC 61131-2 Discrete input DI5, DI6 : level 1 PLC conforming to IEC 65A-68 Discrete input STOA, STOB : level 1 PLC conforming to EN/IEC 61131-2
Discrete input logic	DI1...DI6, positive logic (source) : , $<$ 5 V (state 0), $>$ 11 V (state 1) DI1...DI6, negative logic (sink) : , $>$ 16 V (state 0), $<$ 10 V (state 1) DI5, DI6, positive logic (source) : , $<$ 0.6 V (state 0), $>$ 2.5 V (state 1) STOA, STOB, positive logic (source) : , $<$ 5 V (state 0), $>$ 11 V (state 1)
Analogue output number	2
Analogue output type	Software-configurable voltage AO1, AO2 : 0...10 V DC impedance 470 Ohm, resolution 10 bits Software-configurable current AO1, AO2 : 0...20 mA, resolution 10 bits
Sampling duration	Discrete input DI1...DI4 : 2 ms (+/- 0.5 ms) Discrete input DI5, DI6 : 5 ms (+/- 1 ms) Analog input AI1, AI2, AI3 : 5 ms (+/- 0.1 ms) Analog output AO1 : 10 ms (+/- 1 ms)
Accuracy	Analog input AI1, AI2, AI3 : +/- 0.6 % for a temperature variation 60 °C Analog output AO1, AO2 : +/- 1 % for a temperature variation 60 °C
Linearity error	Analog input AI1, AI2, AI3 : +/- 0.15 % of maximum value Analog output AO1, AO2 : +/- 0.2 %
Relay output number	3
Relay output type	Configurable relay logic R1 : fault relay NO/NC electrical durability 100000 cycles Configurable relay logic R2 : sequence relay NO electrical durability 100000 cycles Configurable relay logic R3 : sequence relay NO electrical durability 100000 cycles
Refresh time	Relay output R1, R2, R3 : 5 ms (+/- 0.5 ms)
Minimum switching current	Relay output R1, R2, R3 : 5 mA at 24 V DC
Maximum switching current	Relay output R1, R2, R3 on resistive load (cos phi = 1) : 3 A at 250 V AC Relay output R1, R2, R3 on resistive load (cos phi = 1) : 3 A at 30 V DC Relay output R1, R2, R3 on inductive load (cos phi = 0.4 and L/R = 7 ms) : 2 A at 250 V AC Relay output R1, R2, R3 on inductive load (cos phi = 0.4 and L/R = 7 ms) : 2 A at 30 V DC
Isolation	Between power and control terminals
IP degree of protection	IP55

## Environment

Insulation resistance	$>$ 1 mOhm at 500 V DC for 1 minute to earth
Noise level	52 dB conforming to 86/188/EEC
Operating position	Vertical +/- 10 degree
THDI	$\leq$ 48 % full load conforming to IEC 61000-3-12
Electromagnetic compatibility	Electrostatic discharge immunity test conforming to IEC 61000-4-2 level 3 Radiated radio-frequency electromagnetic field immunity test conforming to IEC 61000-4-3 level 3 Electrical fast transient/burst immunity test conforming to IEC 61000-4-4 level 4 1.2/50 $\mu$ s - 8/20 $\mu$ s surge immunity test conforming to IEC 61000-4-5 level 3 Conducted radio-frequency immunity test conforming to IEC 61000-4-6 level 3
Pollution degree	2 conforming to EN/IEC 61800-5-1

Vibration resistance	1.5 mm peak to peak (f = 2...13 Hz) conforming to IEC 60068-2-6 1 gn (f = 13...200 Hz) conforming to IEC 60068-2-6
Shock resistance	15 gn during 11 ms conforming to IEC 60068-2-27
Relative humidity	5...95 % without condensation conforming to IEC 60068-2-3
Ambient air temperature for operation	-15...40 °C without derating 40...50 °C with derating factor
Ambient air temperature for storage	-40...70 °C
Operating altitude	<= 1000 m without derating 1000...4800 m with current derating 1 % per 100 m
Environmental characteristic	Chemical pollution resistance class 3C3 EN/IEC 60721-3-3 Dust pollution resistance class 3S3 EN/IEC 60721-3-3
Standards	UL 508C EN/IEC 61800-3 EN/IEC 61800-3 environment 1 category C2 EN/IEC 61800-3 environment 2 category C3 EN/IEC 61800-5-1 IEC 61000-3-12 IEC 60721-3 IEC 61508 IEC 13849-1
Product certifications	ATEX INERIS ATEX zone 2/22 CSA TÜV UL REACH DNV-GL
Marking	CE

### Offer Sustainability

Sustainable offer status	Not Green Premium product
RoHS (date code: YYWW)	Compliant - since 1526 - <a href="#">Schneider Electric declaration of conformity</a>
REACH	Reference contains SVHC above the threshold - <a href="#">go to CaP for more details</a>
Product environmental profile	Available <a href="#">Download Product Environmental</a>

Dimensions

IP55 / UL Type 12 Drives Without Load Switch - Front and Left View

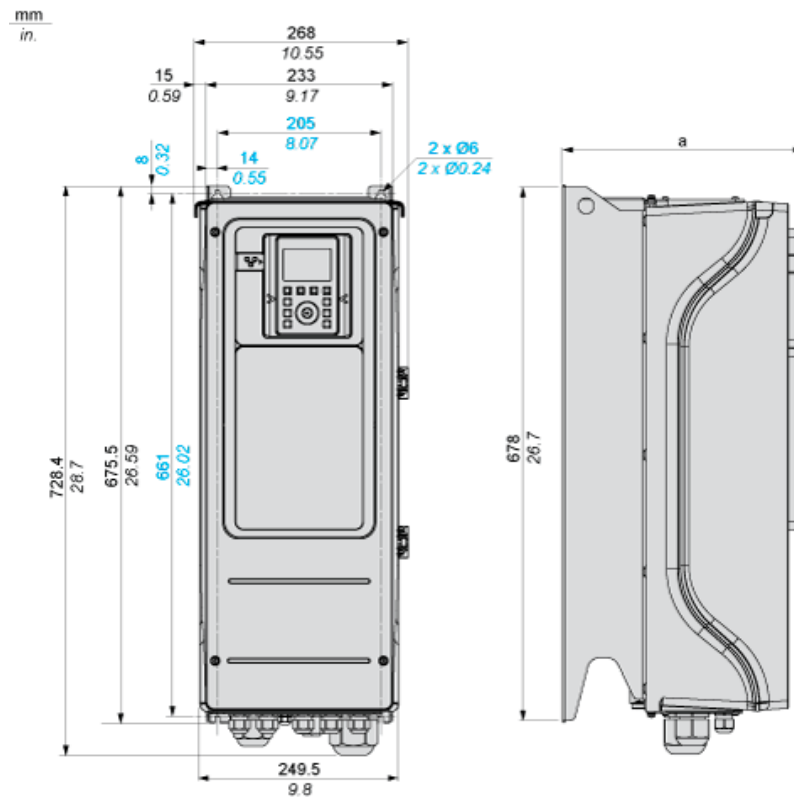

a = 272 mm (10.7 in.)

Clearances

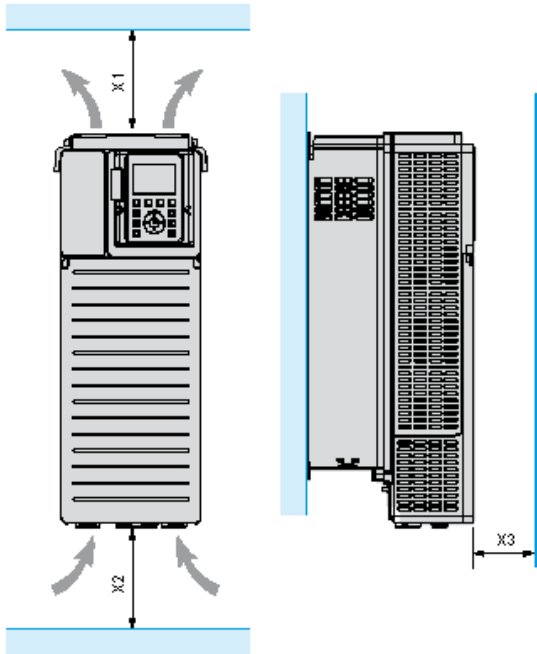

X1	X2	X3
≥ 100 mm (3.94 in.)	≥ 100 mm (3.94 in.)	≥ 10 mm (0.39 in.)

- Mount the device in a vertical position ( $\pm 10^\circ$ ). This is required for cooling the device.
- Do not mount the device close to heat sources.
- Leave sufficient free space so that the air required for cooling purposes can circulate from the bottom to the top of the drive.

Single or Three-Phase Power Supply with Upstream Breaking via Line Contactor

Connection diagrams conforming to standards EN 954-1 category 1 and IEC/EN 61508 capacity SIL1, stopping category 0 in accordance with standard IEC/EN 60204-1

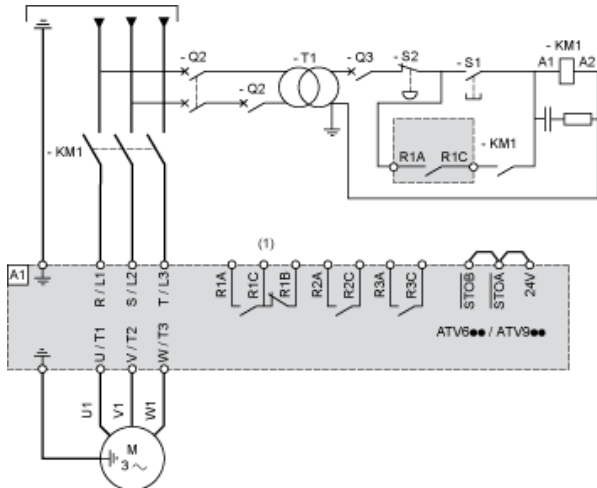

- (1) Use digital output R1 set to operating state Fault to switch Off the product once an error is detected.
- A1 : Drive
- KM1 Line Contactor
- Q2, Circuit breakers
- Q3 :
- S1, Pushbuttons
- S2 :
- T1 : Transformer for control part

Single or Three-Phase Power Supply with Downstream Breaking via Switch Disconnecter

Connection diagrams conforming to standards EN 954-1 category 1 and IEC/EN 61508 capacity SIL1, stopping category 0 in accordance with standard IEC/EN 60204-1

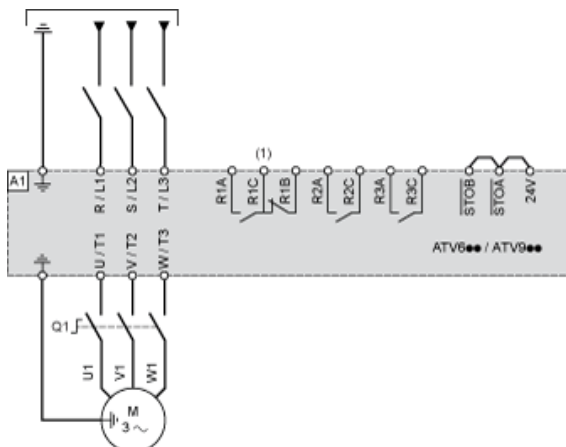

- (1) Use digital output R1 set to operating state Fault to switch Off the product once an error is detected.
- A1 : Drive
- Q1 : Switch disconnector

Control Block Wiring Diagram

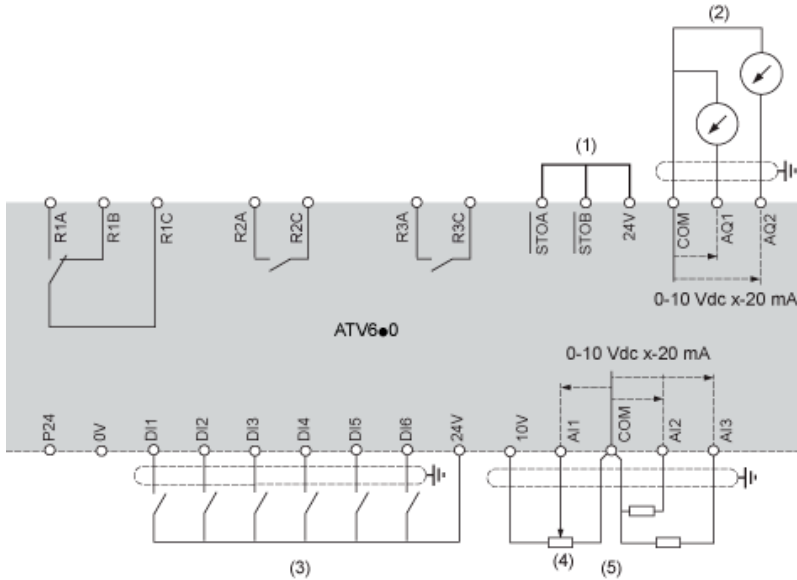

- (1) Safe Torque Off
  - (2) Analog Output
  - (3) Digital Input
  - (4) Reference potentiometer
  - (5) Analog Input
- A1 : ATV6.. Drive  
 R1A, Fault relay  
 R1B,  
 R1C :  
 R2A, Sequence relay  
 R2C :  
 R3A, Sequence relay  
 R3C :

### Sensor Connection

It is possible to connect either 1 or 3 sensors on terminals AI2 or AI3.

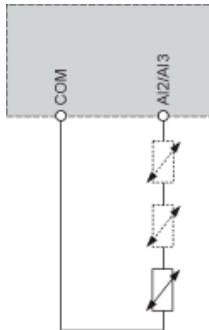

### Sink / Source Switch Configuration

The switch is used to adapt the operation of the logic inputs to the technology of the programmable controller outputs.

- Set the switch to Source (factory setting) if using PLC outputs with PNP transistors.
- Set the switch to Ext if using PLC outputs with NPN transistors.

### Switch Set to SRC (Source) Position Using the Output Power Supply for the Digital Inputs

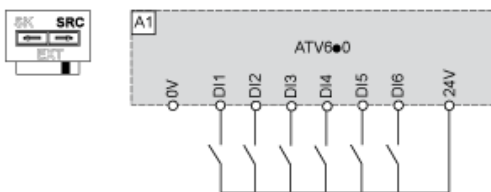

### Switch Set to SRC (Source) Position and Use of an External Power Supply for the DIs

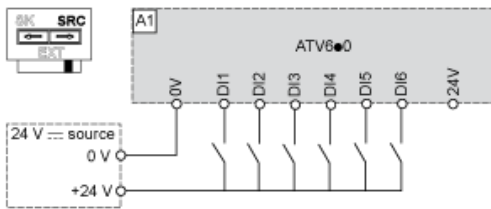

### Switch Set to SK (Sink) Position Using the Output Power Supply for the Digital Inputs

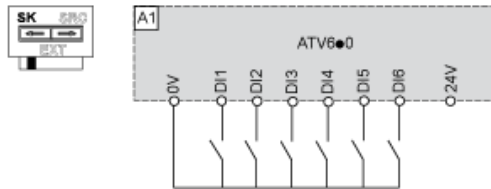

### Switch Set to EXT Position Using an External Power Supply for the DIs

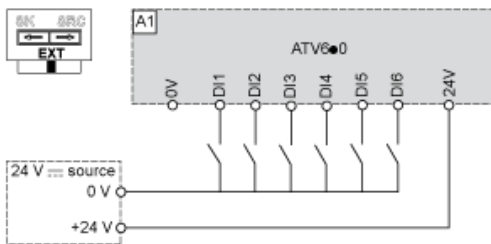

Derating Curves

