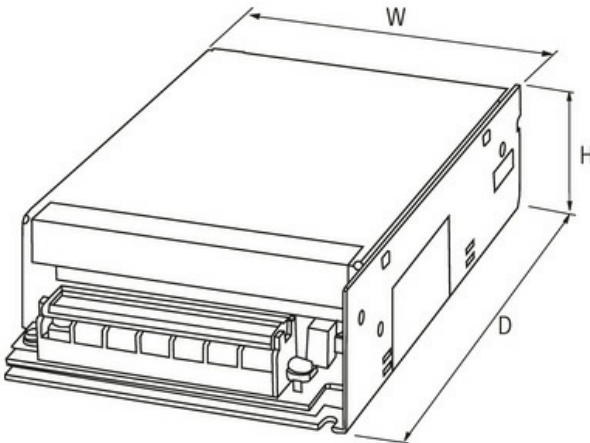
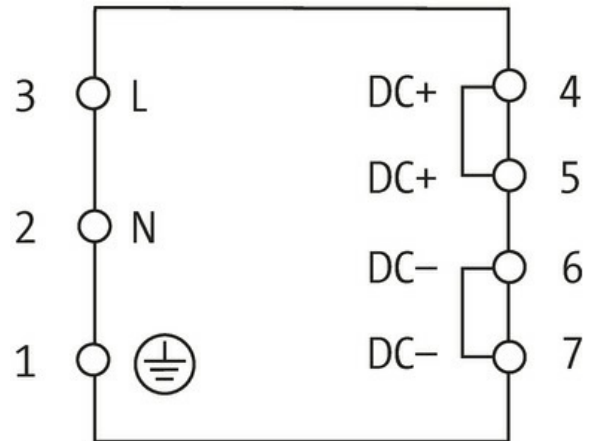

ECO-POWER POWER SUPPLY 1-PHASE,

IN: 90-264 VAC OUT: 24V/2,5ADC

INPUT: 100...240 V AC
 OUTPUT: 24 V DC \pm 1%
 Current: 2.5 A

[Link to Product](#)**Illustration**

Product may differ from Image

General data

Standards	IEC 61010-2-201, EN 61204-3, EN 55011 B
Mounting method	screw fixing, M3
Temperature range	0...+40 °C, ...+50 °C derating (storage temperature -20...+85 °C)
Relative humidity	20...90%, no condensation
Efficiency	85% (115 V AC); 87% (230 V AC)
Dimensions HxWxD	40x98x135 mm

Output

Output voltage	24 V DC \pm 1%
LED display	LED (green) for output voltage
Output current	2.5 A (+40 °C); 2.0 A (+50 °C)
Mains failure bridging time	min. 10 ms (115 V AC); min. 90 ms (230 V AC)

Ripple	max. 20 mV eff/rms
Spikes	max. 100 mV ss/pp
Unit protection	short-circuit and overload protected
Parallel usage/serial usage	no/yes (max. 2 units)

Input

Input voltage	100...240 V AC
Primary fusing external	max. 16 A
Input current	1.2 A (115 V AC); 0.5 A (230 V AC)
Inrush current after 1 ms	max. 20 A
Frequency	50...60 Hz

Commercial data

country of origin	CN
customs tariff number	85044082
EAN	4048879080439
eClass	27049002
Packaging unit	1.000