

ATV61HC16Y

variable speed drive ATV61 - 160kW / 690V - IP20



Main

Range of product	Altivar 61
Product or component type	Variable speed drive
Product specific application	Pumping and ventilation machine
Component name	ATV61
Motor power kW	160 kW 3 phases at 690 V 132 kW 3 phases at 500 V
Power supply voltage	500...690 V (- 15...10 %)
Supply number of phases	3 phases
Line current	158.9 A for 600 V 3 phases 132 kW 182 A for 500 V 3 phases 132 kW 163 A for 690 V 3 phases 132 kW
EMC filter	Level 3 EMC filter
Assembly style	With heat sink
Maximum prospective line I _{sc}	28 kA 3 phases
Maximum transient current	240 A for 60 s 3 phases
Nominal switching frequency	2.5 kHz
Switching frequency	2.5...4.9 kHz with derating factor 2.5...4.9 kHz adjustable
Asynchronous motor control	Voltage/Frequency ratio, 2 points Voltage/Frequency ratio, 5 points Flux vector control without sensor, standard Voltage/Frequency ratio - Energy Saving, quadratic U/f
Synchronous motor control profile	Vector control without sensor, standard
Communication port protocol	CANopen Modbus
Type of polarization	No impedance for Modbus
Option card	Profibus DP V1 communication card Profibus DP communication card Multi-pump card Modbus/Uni-Telway communication card Modbus TCP communication card Modbus Plus communication card METASYS N2 communication card LonWorks communication card Interbus-S communication card I/O extension card Fipio communication card Ethernet/IP communication card DeviceNet communication card Controller inside programmable card CC-Link communication card BACnet communication card APOGEE FLN communication card

The information provided in this documentation contains general descriptions and/or technical characteristics of the performance of the products contained herein. This documentation is not intended as a substitute for and is not to be used for determining suitability or reliability of these products for specific user applications. It is the duty of any such user or integrator to perform the appropriate and complete risk analysis, evaluation and testing of the products with respect to the relevant specific application or use thereof. Neither Schneider Electric Industries SAS nor any of its affiliates or subsidiaries shall be responsible or liable for misuse of the information contained herein.

Complementary

Product destination	Asynchronous motors Synchronous motors
Power supply voltage limits	425...759 V
Power supply frequency	50...60 Hz (- 5...5 %)
Power supply frequency limits	47.5...63 Hz
Continuous output current	200 A at 2.5 kHz, 500 V 3 phases 180 A at 2.5 kHz, 690 V 3 phases
Speed drive output frequency	0.1...500 Hz
Speed range	1...100 in open-loop mode, without speed feedback
Speed accuracy	+/- 10 % of nominal slip for 0.2 Tn to Tn torque variation without speed feedback
Torque accuracy	+/- 15 % in open-loop mode, without speed feedback
Transient overtorque	130 % of nominal motor torque, +/- 10 % for 60 s
Braking torque	30 % without braking resistor ≤ 125 % with braking resistor
Regulation loop	Frequency PI regulator
Motor slip compensation	Adjustable Automatic whatever the load Can be suppressed Not available in voltage/frequency ratio (2 or 5 points)
Diagnostic	1 LED red presence of drive voltage
Output voltage	≤ power supply voltage
Electrical isolation	Between power and control terminals
Type of cable for mounting in an enclosure	Without mounting kit : 1-strand IEC cable at 45 °C, copper 90 °C XLPE/EPR Without mounting kit : 1-strand IEC cable at 45 °C, copper 70 °C PVC With UL Type 1 kit : 3-strand UL 508 cable at 40 °C, copper 75 °C PVC With an IP21 or an IP31 kit : 3-strand IEC cable at 40 °C, copper 70 °C PVC
Electrical connection	PC/-, PA/+ terminal 2 x 120 mm ² / 2 x 250 kcmil PA, PB terminal 120 mm ² / 250 kcmil L1/R, L2/S, L3/T, U/T1, V/T2, W/T3 terminal 2 x 120 mm ² / 2 x 250 kcmil AI1-/AI1+, AI2, AO1, R1A, R1B, R1C, R2A, R2B, LI1...LI6, PWR terminal 2.5 mm ² / AWG 14
Tightening torque	PC/-, PA/+ 24 N.m / 212 lb.in PA, PB 24 N.m / 212 lb.in L1/R, L2/S, L3/T, U/T1, V/T2, W/T3 24 N.m / 212 lb.in AI1-/AI1+, AI2, AO1, R1A, R1B, R1C, R2A, R2B, LI1...LI6, PWR 0.6 N.m
Supply	Internal supply 24 V DC (21...27 V), ≤ 200 mA for overload and short-circuit protection Internal supply for reference potentiometer (1 to 10 kOhm) 10.5 V DC +/- 5 %, ≤ 10 mA for overload and short-circuit protection External supply 24 V DC (19...30 V), 30 W
Analogue input number	2
Analogue input type	AI2 software-configurable voltage 0...10 V DC, input voltage 24 V max, impedance 30000 Ohm, resolution 11 bits AI2 software-configurable current 0...20 mA, impedance 242 Ohm, resolution 11 bits AI1-/AI1+ bipolar differential voltage +/- 10 V DC, input voltage 24 V max, resolution 11 bits + sign
Sampling time	Discrete input LI6 (if configured as logic input) 2 ms, +/- 0.5 ms Discrete input LI1...LI5 2 ms, +/- 0.5 ms Analog output AO1 2 ms, +/- 0.5 ms Analog input AI2 2 ms, +/- 0.5 ms Analog input AI1-/AI1+ 2 ms, +/- 0.5 ms
Absolute accuracy precision	AO1 +/- 1 % for a temperature variation 60 °C AI2 +/- 0.6 % for a temperature variation 60 °C AI1-/AI1+ +/- 0.6 % for a temperature variation 60 °C
Linearity error	AO1 +/- 0.2 % AI2 +/- 0.15 % of maximum value AI1-/AI1+ +/- 0.15 % of maximum value
Analogue output number	1
Analogue output type	AO1 software-configurable logic output 10 V, ≤ 20 mA AO1 software-configurable voltage, analogue output range 0...10 V DC, impedance 470 Ohm, resolution 10 bits AO1 software-configurable current, analogue output range 0...20 mA, impedance 500 Ohm, resolution 10 bits
Discrete output number	2

Discrete output type	(R2A, R2B) configurable relay logic NO, electrical durability 100000 cycles (R1A, R1B, R1C) configurable relay logic NO/NC, electrical durability 100000 cycles
Maximum response time	R2A, R2B <= 7 ms, tolerance +/- 0.5 ms R1A, R1B, R1C <= 7 ms, tolerance +/- 0.5 ms <= 100 ms in STO (Safe Torque Off)
Minimum switching current	Configurable relay logic 3 mA at 24 V DC
Maximum switching current	R1, R2 on resistive load, 5 A at 30 V DC, cos phi = 1, L/R = 0 ms R1, R2 on resistive load, 5 A at 250 V AC, cos phi = 1, L/R = 0 ms R1, R2 on inductive load, 2 A at 30 V DC, cos phi = 0.4, L/R = 7 ms R1, R2 on inductive load, 2 A at 250 V AC, cos phi = 0.4, L/R = 7 ms
Discrete input number	7
Discrete input type	(PWR) safety input, 24 V DC, voltage limits <= 30 V, impedance 1500 Ohm (LI6) switch-configurable PTC probe, 0...6, impedance 1500 Ohm (LI6) switch-configurable, 24 V DC, voltage limits <= 30 V, with level 1 PLC, impedance 3500 Ohm (LI1...LI5) programmable, 24 V DC, voltage limits <= 30 V, with level 1 PLC, impedance 3500 Ohm
Discrete input logic	LI6 (if configured as logic input) positive logic (source), < 5 V (state 0), > 11 V (state 1) LI6 (if configured as logic input) negative logic (sink), > 16 V (state 0), < 10 V (state 1) LI1...LI5 positive logic (source), < 5 V (state 0), > 11 V (state 1) LI1...LI5 negative logic (sink), > 16 V (state 0), < 10 V (state 1)
Acceleration and deceleration ramps	Automatic adaptation of ramp if braking capacity exceeded, by using resistor Linear adjustable separately from 0.01 to 9000 s S, U or customized
Braking to standstill	By DC injection
Protection type	Motor thermal protection Motor power removal Motor motor phase break Drive thermal protection Drive short-circuit between motor phases Drive power removal Drive overvoltages on the DC bus Drive overheating protection Drive overcurrent between output phases and earth Drive line supply undervoltage Drive line supply overvoltage Drive input phase breaks Drive break on the control circuit Drive against input phase loss Drive against exceeding limit speed
Insulation resistance	> 1 mOhm at 500 V DC for 1 minute to earth
Frequency resolution	Display unit 0.1 Hz Analog input 0.024/50 Hz
Type of connector	Male SUB-D 9 on RJ45 for CANopen 1 RJ45 for Modbus on terminal 1 RJ45 for Modbus on front face
Physical interface	2-wire RS 485 for Modbus
Transmission frame	RTU for Modbus
Transmission rate	20 kbps, 50 kbps, 125 kbps, 250 kbps, 500 kbps, 1 Mbps for CANopen 9600 bps, 19200 bps for Modbus on front face 4800 bps, 9600 bps, 19200 bps, 38.4 Kbps for Modbus on terminal
Data format	8 bits, odd even or no configurable parity for Modbus on terminal 8 bits, 1 stop, even parity for Modbus on front face
Number of addresses	1...247 for Modbus 1...127 for CANopen
Method of access	Slave for CANopen
Marking	CE
Operating position	Vertical +/- 10 degree
Product weight	102 kg
Width	340 mm
Height	1190 mm
Depth	377 mm

Environment

Noise level	77 dB conforming to 86/188/EEC
Dielectric strength	5345 V DC between control and power terminals 3110 V DC between earth and power terminals
Electromagnetic compatibility	Voltage dips and interruptions immunity test conforming to IEC 61000-4-11 Radiated radio-frequency electromagnetic field immunity test conforming to IEC 61000-4-3 level 3 Electrostatic discharge immunity test conforming to IEC 61000-4-2 level 3 Electrical fast transient/burst immunity test conforming to IEC 61000-4-4 level 4 Conducted radio-frequency immunity test conforming to IEC 61000-4-6 level 3
Standards	EN 55011 class A group 2 EN 61800-3 environments 1 category C3 EN 61800-3 environments 2 category C3 EN/IEC 61800-3 EN/IEC 61800-5-1 IEC 60721-3-3 class 3C2 UL Type 1
Product certifications	CSA C-Tick DNV GOST NOM 117 UL
Pollution degree	3 conforming to UL 840 3 conforming to EN/IEC 61800-5-1
Degree of protection	IP30 on the front panel conforming to EN/IEC 61800-5-1 IP30 on the front panel conforming to EN/IEC 60529 IP30 on side parts conforming to EN/IEC 61800-5-1 IP30 on side parts conforming to EN/IEC 60529 IP00 conforming to EN/IEC 61800-5-1 IP00 conforming to EN/IEC 60529 IP54 on lower part conforming to EN/IEC 61800-5-1 IP54 on lower part conforming to EN/IEC 60529 IP41 on upper part conforming to EN/IEC 61800-5-1 IP41 on upper part conforming to EN/IEC 60529
Vibration resistance	1.5 mm peak to peak (f = 3...10 Hz) conforming to EN/IEC 60068-2-6 0.6 gn (f = 10...200 Hz) conforming to EN/IEC 60068-2-6
Shock resistance	7 gn for 11 ms conforming to EN/IEC 60068-2-27
Relative humidity	5...95 % without dripping water conforming to IEC 60068-2-3 5...95 % without condensation conforming to IEC 60068-2-3
Ambient air temperature for operation	50...60 °C with derating factor -10...50 °C without derating
Ambient air temperature for storage	-25...70 °C
Operating altitude	1000...2260 m with current derating 1 % per 100 m <= 1000 m without derating

Offer Sustainability

Sustainable offer status	Not Green Premium product
RoHS (date code: YYWW)	Compliant - since 1002 - Schneider Electric declaration of conformity
REACH	Reference contains SVHC above the threshold - go to CaP for more details
Product environmental profile	Available Download Product Environmental

UL Type 1/IP 20 Drives

Dimensions with or without 1 Option Card (1)

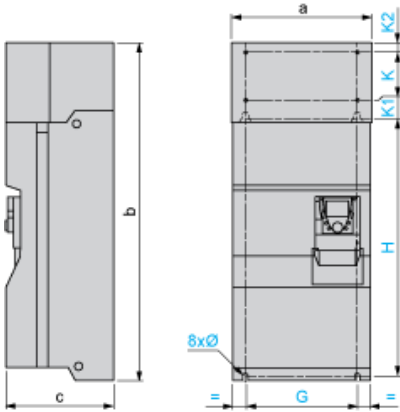

Dimensions in mm

a	b	c	G	H	K	K1	K2	Ø
340	1190	377	285	920	150	75	30	11.5

Dimensions in in.

a	b	c	G	H	K	K1	K2	Ø
13.39	46.85	14.84	11.22	36.22	5.90	2.95	1.18	0.45

(1) Option cards: I/O extension cards, communication cards or "Controller Inside" programmable card.

Dimensions with 2 Option Cards (1)

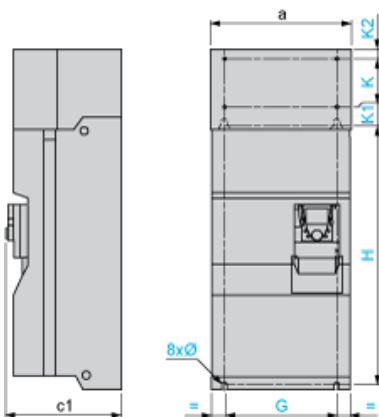

Dimensions in mm

a	c1	G	H	K	K1	K2	Ø
340	392	285	920	150	75	30	11.5

Dimensions in in.

a	c1	G	H	K	K1	K2	Ø
13.39	15.43	11.22	36.22	5.90	2.95	1.18	0.45

(1) Option cards: I/O extension cards, communication cards or "Controller Inside" programmable card.

Mounting Recommendations

Clearance

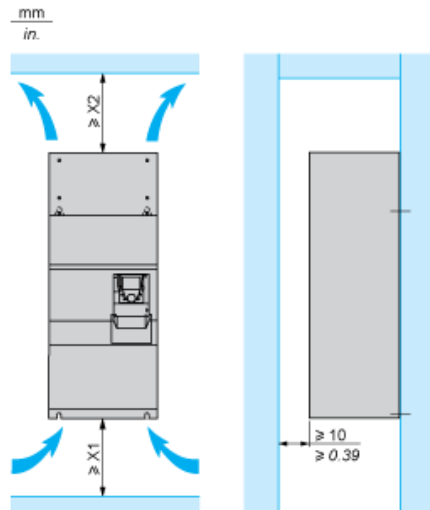

X1 in mm	X2 in mm	X1 in in.	X2 in in.
150	150	5.91	5.91

These drives can be mounted side by side, observing the following mounting recommendations:

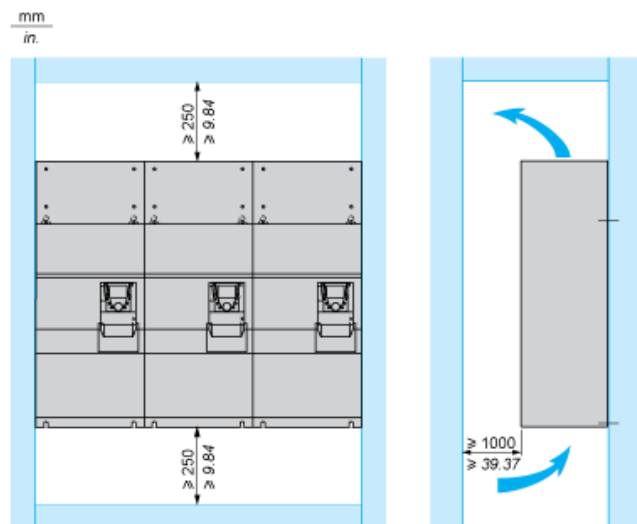

Specific Recommendations for Mounting the Drive in an Enclosure

Ventilation

To ensure proper air circulation in the drive:

- Fit ventilation grilles.
- Ensure that there is sufficient ventilation. If there is not, install a forced ventilation unit with a filter. The openings and/or fans must provide a flow rate at least equal to that of the drive fans (refer to the product characteristics).

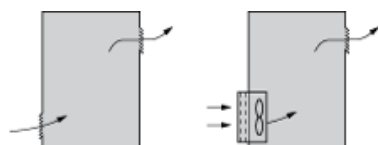

- Use special filters with IP 54 protection.
- Remove the blanking cover from the top of the drive.

Dust and Damp Proof Metal Enclosure (IP 54)

The drive must be mounted in a dust and damp proof enclosure in certain environmental conditions: dust, corrosive gases, high humidity with risk of condensation and dripping water, splashing liquid, etc.

This enables the drive to be used in an enclosure where the maximum internal temperature reaches 50°C.

Wiring Diagram Conforming to Standards EN 954-1 Category 1, IEC/EN 61508 Capacity SIL1, in Stopping Category 0 According to IEC/EN 60204-1

Three-Phase Power Supply with Upstream Breaking via Contactor

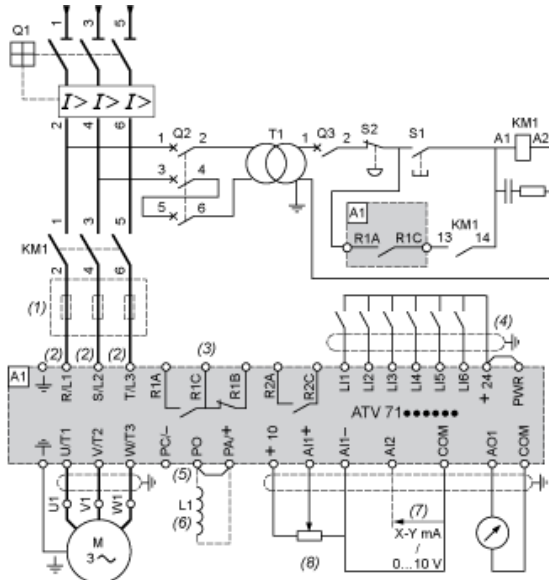

- A1 ATV61 drive
- KM1 Contactor
- L1 DC choke
- Q1 Circuit-breaker
- Q2 GV2 L rated at twice the nominal primary current of T1
- Q3 GB2CB05
- S1, XB4 B or XB5 A pushbuttons
- S2
- T1 100 VA transformer 220 V secondary
- (1) Line choke (three-phase); mandatory for ATV61HC11Y...HC80Y drives (except when a special transformer is used (12-pulse)).
- (2) For ATV61HC50N4, ATV61HC63N4 and ATV61HC50Y...HC80Y drives, refer to the power terminal connections diagram.
- (3) Fault relay contacts. Used for remote signalling of the drive status.
- (4) Connection of the common for the logic inputs depends on the positioning of the SW1 switch. The above diagram shows the internal power supply switched to the "source" position (for other connection types, refer to the user guide).
- (5) There is no PO terminal on ATV61HC11Y...HC80Y drives.
- (6) Optional DC choke for ATV61H...M3, ATV61HD11M3X...HD45M3X and ATV61H075N4...HD75N4 drives. Connected in place of the strap between the PO and PA/+ terminals. For ATV61HD55M3X...HD90M3X, ATV61HD90N4...HC63N4 drives, the choke is supplied with the drive; the customer is responsible for connecting it. For ATV61W...N4 and ATV61W...N4C drives, the DC choke is integrated.
- (7) Software-configurable current (0...20 mA) or voltage (0...10 V) analog input.
- (8) Reference potentiometer.

NOTE: All terminals are located at the bottom of the drive. Fit interference suppressors on all inductive circuits near the drive or connected on the same circuit, such as relays, contactors, solenoid valves, fluorescent lighting, etc.

Wiring Diagram Conforming to Standards EN 954-1 Category 1, IEC/EN 61508 Capacity SIL1, in Stopping Category 0 According to IEC/EN 60204-1

Three-Phase Power Supply with Downstream Breaking via Switch Disconnecter

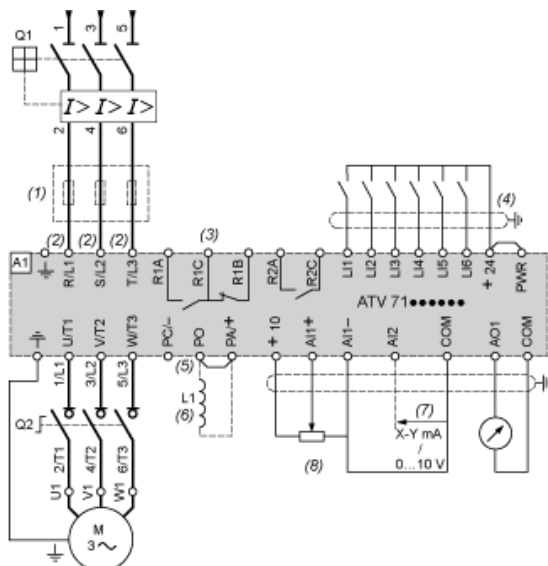

- A1 ATV61 drive
- L1 DC choke
- Q1 Circuit-breaker
- Q2 Switch disconnecter (Vario)
- (1) Line choke (three-phase), mandatory for ATV61HC11Y...HC80Y drives (except when a special transformer is used (12-pulse)).
- (2) For ATV61HC50N4, ATV61HC63N4 and ATV61HC50Y...HC80Y drives, refer to the power terminal connections diagram.
- (3) Fault relay contacts. Used for remote signalling of the drive status.
- (4) Connection of the common for the logic inputs depends on the positioning of the SW1 switch. The above diagram shows the internal power supply switched to the "source" position (for other connection types, refer to the user guide).
- (5) There is no PO terminal on ATV61HC11Y...HC80Y drives.
- (6) Optional DC choke for ATV61H...M3, ATV61HD11M3X...HD45M3X and ATV61H075N4...HD75N4 drives. Connected in place of the strap between the PO and PA/+ terminals. For ATV61HD55M3X...HD90M3X, ATV61HD90N4...HC63N4 drives, the choke is supplied with the drive; the customer is responsible for connecting it. For ATV61W...N4 and ATV61W...N4C drives, the DC choke is integrated.
- (7) Software-configurable current (0...20 mA) or voltage (0...10 V) analog input.
- (8) Reference potentiometer.

NOTE: All terminals are located at the bottom of the drive. Fit interference suppressors on all inductive circuits near the drive or connected on the same circuit, such as relays, contactors, solenoid valves, fluorescent lighting, etc.

Wiring Diagram Conforming to Standards EN 954-1 Category 3, IEC/EN 61508 Capacity SIL2, in Stopping Category 0 According to IEC/EN 60204-1

Three-Phase Power Supply, Low Inertia Machine, Vertical Movement

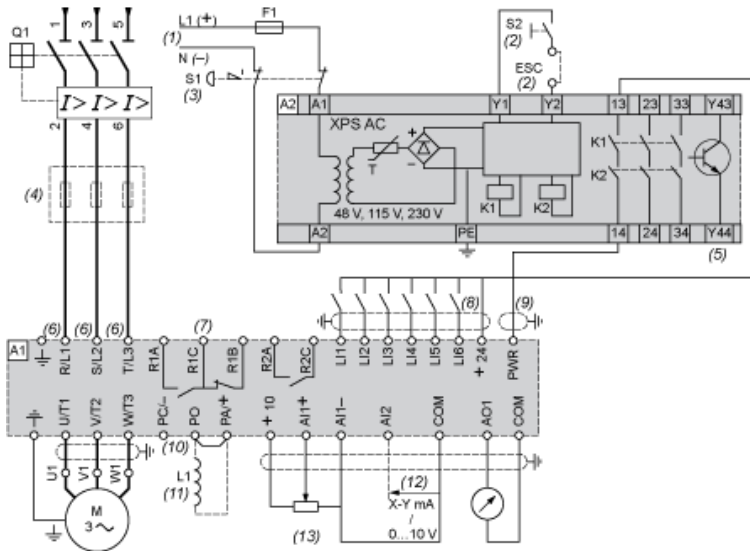

- A1 ATV61 drive
- A2 Preventa XPS AC safety module for monitoring emergency stops and switches. One safety module can manage the “Power Removal” function for several drives on the same machine. In this case, each drive must connect its PWR terminal to its + 24 V via the safety contacts on the XPS AC module. These contacts are independent for each drive.
- F1 Fuse
- L1 DC choke
- Q1 Circuit-breaker
- S1 Emergency stop button with 2 contacts
- S2 XB4 B or XB5 A pushbutton
- (1) Power supply: 24 Vdc or Vac, 115 Vac, 230 Vac.
- (2) S2: resets XPS AC module on power-up or after an emergency stop. ESC can be used to set external starting conditions.
- (3) Requests freewheel stopping of the movement and activates the “Power Removal” safety function.
- (4) Line choke (three-phase), mandatory for and ATV61HC11Y...HC80Y drives (except when a special transformer is used (12-pulse)).
- (5) The logic output can be used to signal that the machine is in a safe stop state.
- (6) For ATV61HC50N4, ATV61HC63N4 and ATV61HC50Y...HC80Y drives, refer to the power terminal connections diagram.
- (7) Fault relay contacts. Used for remote signalling of the drive status.
- (8) Connection of the common for the logic inputs depends on the positioning of the SW1 switch. The above diagram shows the internal power supply switched to the “source” position (for other connection types, refer to the user guide).
- (9) Standardized coaxial cable, type RG174/U according to MIL-C17 or KX3B according to NF C 93-550, external diameter 2.54 mm / 0.09 in., maximum length 15 m / 49.21 ft. The cable shielding must be earthed.
- (10) There is no PO terminal on ATV61HC11Y...HC80Y drives.
- (11) Optional DC choke for ATV61H...M3, ATV61HD11M3X...HD45M3X and ATV61H075N4...HD75N4 drives. Connected in place of the strap between the PO and PA/+ terminals. For ATV61HD55M3X...HD90M3X, ATV61HD90N4...HC63N4 drives, the choke is supplied with the drive; the customer is responsible for connecting it. For ATV61W...N4 and ATV61W...N4C drives, the DC choke is integrated.
- (12) Software-configurable current (0...20 mA) or voltage (0...10 V) analog input.
- (13) Reference potentiometer.

NOTE: All terminals are located at the bottom of the drive. Fit interference suppressors on all inductive circuits near the drive or connected on the same circuit, such as relays, contactors, solenoid valves, fluorescent lighting, etc.

Wiring Diagram Conforming to Standards EN 954-1 Category 3, IEC/EN 61508 Capacity SIL2, in Stopping Category 1 According to IEC/EN 60204-1

Three-Phase Power Supply, High Inertia Machine

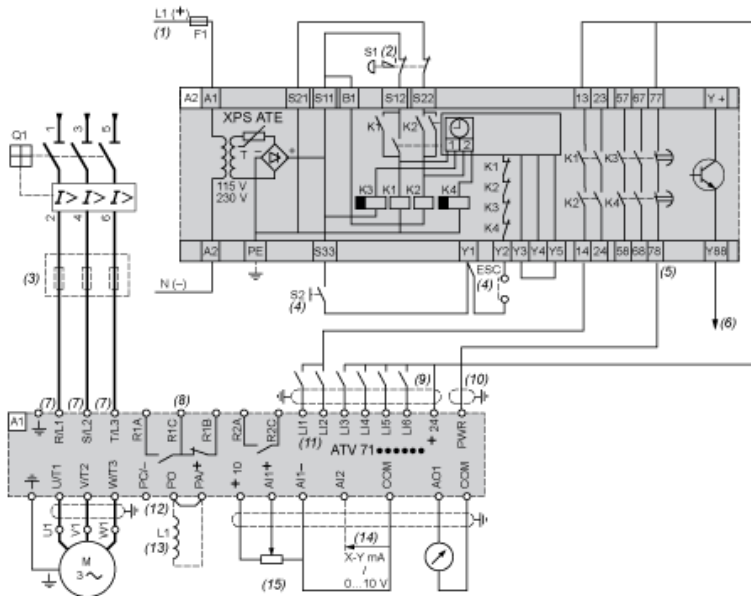

- A1 ATV61 drive
A2 Preventa XPS ATE safety module for monitoring emergency stops and switches. One safety module can manage the "Power Removal"
(5) safety function for several drives on the same machine. In this case the time delay must be adjusted on the drive controlling the motor that requires the longest stopping time. In addition, each drive must connect its PWR terminal to its + 24 V via the safety contacts on the XPS ATE module. These contacts are independent for each drive.
- F1 Fuse
L1 DC choke
Q1 Circuit-breaker
S1 Emergency stop button with 2 contacts
S2 XB4 B or XB5 A pushbutton
- (1) Power supply: 24 Vdc or Vac, 115 Vac, 230 Vac.
(2) Requests controlled stopping of the movement and activates the "Power Removal" safety function.
(3) Line choke (three-phase), mandatory for ATV61HC11Y...HC80Y drives (except when a special transformer is used (12-pulse)).
(4) S2: resets XPS ATE module on power-up or after an emergency stop. ESC can be used to set external starting conditions.
(5) The logic output can be used to signal that the machine is in a safe state.
(6) For stopping times requiring more than 30 seconds in category 1, use a Preventa XPS AV safety module which can provide a maximum time delay of 300 seconds.
(7) For ATV61HC50N4, ATV61HC63N4 and ATV61HC50Y...HC80Y drives, refer to the power terminal connections diagram.
(8) Fault relay contacts. Used for remote signalling of the drive status.
(9) Connection of the common for the logic inputs depends on the positioning of the SW1 switch. The above diagram shows the internal power supply switched to the "source" position (for other connection types, refer to the user guide).
(10) Standardized coaxial cable, type RG174/U according to MIL-C17 or KX3B according to NF C 93-550, external diameter 2.54 mm/0.09 in., maximum length 15 m/49.21 ft. The cable shielding must be earthed.
(11) Logic inputs LI1 and LI2 must be assigned to the direction of rotation: LI1 in the forward direction and LI2 in the reverse direction.
(12) There is no PO terminal on ATV61HC11Y...HC80Y drives.
(13) Optional DC choke for ATV61H...M3, ATV61HD11M3X...HD45M3X and ATV61H075N4...HD75N4 drives. Connected in place of the strap between the PO and PA/+ terminals. For ATV61HD55M3X...HD90M3X, ATV61HD90N4...HC63N4 drives, the choke is supplied with the drive; the customer is responsible for connecting it. For ATV61W...N4 and ATV61W...N4C drives, the DC choke is integrated.
(14) Software-configurable current (0...20 mA) or voltage (0...10 V) analog input.
(15) Reference potentiometer.

NOTE: All terminals are located at the bottom of the drive. Fit interference suppressors on all inductive circuits near the drive or connected on the same circuit, such as relays, contactors, solenoid valves, fluorescent lighting, etc.

Derating Curves

The derating curves for the drive nominal current (I_n) depend on the temperature and the switching frequency. For intermediate temperatures (e.g. 55°C), interpolate between 2 curves.

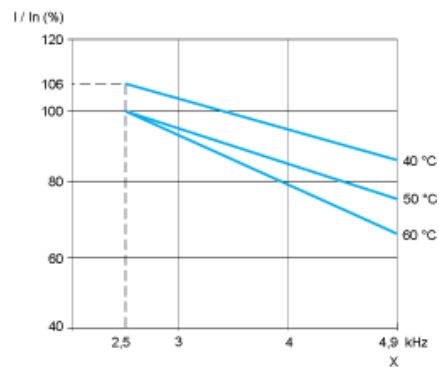

X Switching frequency