

M23 SIGNAL CABLE

Specification: M6FX8002-2CH00-1AF0

Signal cable for SINAMICS S120 and motors with connection M23

Female straight – female 90°

M23, 17-pole – SUB-D25

shielded

Further cable lengths on request.

The resistance to aggressive media should be individually tested for your application. Further details on request.

Plastic housings with good resistance against chemicals and oils.

Link to Product

Illustration

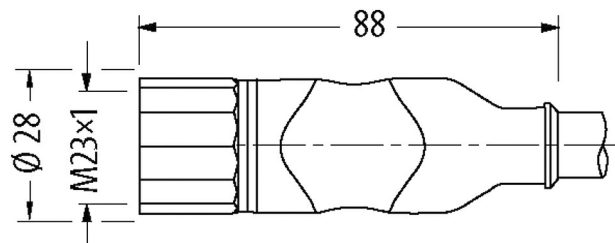
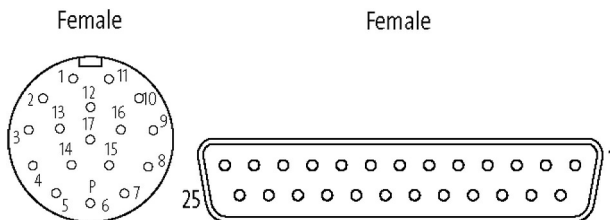
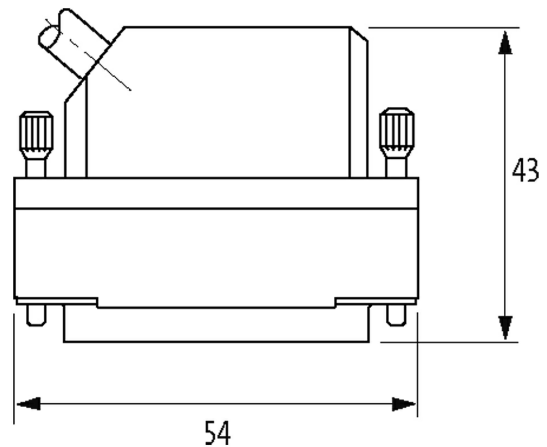
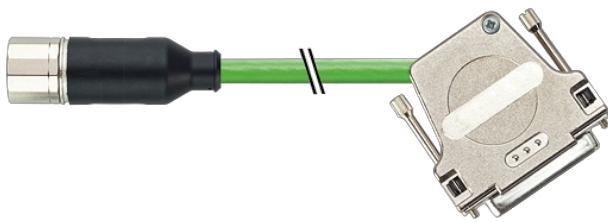

Product may differ from Image

Form

Form SS211

Technical Data

Operating voltage	max. 30 V AC/DC
Locking of ports	Screw thread (M23×1 mm) recommended torque 2.0 Nm, self-securing
Protection	IP20/IP67

General data

Temperature range	-25...+85 °C, depending on cable quality
-------------------	--

Cables

Cable number	882
No./diameter of wires	(3× (2× 0.14D) + 2× 0.5 + 4× 0.14)-C
Wire isolation	PP (ye, gn, bk, br, rd, or, brrd, brbl, gr, bl, whye, whbk)
C-track properties	10 Mio.
Jacket Color	green

Material (jacket)	PUR (UL/CSA)
Outer Ø	8.9 mm ±5%
Bend radius (fixed)	10× outer Ø
Bend radius (moving)	12× outer Ø
Temperature range (fixed)	-50...+80 °C
Temperature range (mobile)	-35...+70 °C
Shield	yes

Commercial data

country of origin	DE
customs tariff number	85444290
EAN	4048879481601
eClass	27279218
Packaging unit	1