

ATV71EXC2C11N4H

enclosed variable speed drive ATV71 Plus-LH -
110 kW - 400V - IP23- low harmonic



Main

Range of product	Altivar 71 Plus-LH
Product or component type	Variable speed drive
Device short name	ATV71
Product destination	Asynchronous motors Synchronous motors
Assembly style	In floor-standing enclosure compact version
Kit composition	A line choke A switch and fast-acting fuses An IP65 remote mounting kit for graphic display terminal Terminals/Bars for motor connection A wired ready-assembled Schneider Spacial SF enclosure Active infeed converter Control transformer 230 V AC Power supply 24 V DC Clean power filter with integrated EMC filter ATV71HC11N4 standard drive IP00

Complementary

EMC filter	Integrated
Network number of phases	3 phases
[Us] rated supply voltage	380...415 V (+/- 10 %)
Supply voltage limits	342...457 V
Supply frequency	50...60 Hz (+/- 5 %)
Network frequency limits	47.5...63 Hz
Motor power kW	110 kW 3 phases at 380...415 V
Line current	177 A at 400 V 3 phases 110 kW
Apparent power	123 kVA at 400 V 3 phases 110 kW
Prospective line I _{sc}	100 kA with option circuit breaker 100 kA with external fuses
Continuous output current	215 A 2.5 kHz at 400 V 3 phases
Maximum transient current	323 A for 60 s at 400 V 3 phases
Speed drive output frequency	0.1...500 Hz
Nominal switching frequency	2.5 kHz
Switching frequency	2.5...8 kHz with derating factor 2...8 kHz adjustable
Speed range	1...100 in open-loop mode, without speed feedback
Speed accuracy	+/- 10 % of nominal slip (0.2 T _n to T _n) without speed feedback +/- 0.01 % of nominal speed (0.2 T _n to T _n) in closed-loop mode with encoder feedback
Torque accuracy	+/- 5 % in closed-loop mode with encoder feedback +/- 15 % in open-loop mode, without speed feedback
Transient overtorque	220 % of nominal motor torque (+/- 10 %) 2 s 170 % of nominal motor torque (+/- 10 %) 60 s
Braking torque	120 % for 60 seconds 100 % continuous
Asynchronous motor control profile	ENA (Energy adaptation) system for unbalanced loads Voltage/Frequency ratio (2 or 5 points) Vector control with/without speed feedback
Synchronous motor control profile	Vector control without sensor, standard Vector control with sensor, standard
Regulation loop	Adjustable PI regulator

Motor slip compensation	Adjustable Automatic whatever the load Can be suppressed Not available in voltage/frequency ratio (2 or 5 points)
Overvoltage category	Class 3 conforming to EN 50178
Local signalling	LCD display unit with operation function, status and configuration - mounted in the front door
Output voltage	<= power supply voltage
Isolation	Between power and control terminals
Type of cable	IEC cable at 40 °C copper 70 °C PVC
Electrical connection	Terminal M12, clamping capacity: 2 x 240 mm ² (U/T1, V/T2, W/T3) for entry from the bottom Terminal M10, clamping capacity: 2 x 150 mm ² (L1/R, L2/S, L3/T) for entry from the bottom Terminal, clamping capacity: 2.5 mm ² AWG 14 (AI1-/AI1+, AI2, AO1, R1A, R1B, R1C, R2A, R2B, LI1...LI6, PWR) for entry from the bottom
Motor recommended cable cross section	3 x 120 mm ²
Short circuit protection	250 A for fuse 3 gl power supply upstream
Supply	Internal supply at 24 V DC 21...27 V 0...100 mA Internal supply for reference potentiometer at 10 V DC 10...11 V 0...10 mA External supply at 24 V DC 19...30 V 1 A 30 W
Analogue input number	2
Analogue input type	Software-configurable current (AI2) 0...20 mA/4...20 mA 250 Ohm, duration: 1.5...2.5 ms) 11 bits Bipolar differential voltage (AI1-/AI1+) +/- 10 V DC at 24 V max, duration: 1.5...2.5 ms) 11 bits + sign Software-configurable voltage (AI2) 0...10 V DC at 24 V max 30 kOhm, duration: 1.5...2.5 ms) 11 bits
Analogue output number	1
Analogue output type	Software-configurable current (AO1) 0...20 mA/4...20 mA at 500 Ohm, duration: 1.5...2.5 ms 10 bits Software-configurable voltage (AO1) 0...10 V DC at 470 Ohm, duration: 1.5...2.5 ms 10 bits
Discrete output number	1
Discrete output type	Configurable relay logic (R1A, R1B, R1C) NO/NC, response time: 6.5...7.5 ms - electrical durability: 100000 cycles
Minimum switching current	3 mA at 24 V DC (configurable relay logic)
Maximum switching current	2 A at 30 V DC - load type: inductive L/R = 7 ms configurable relay logic 2 A at 250 V AC - load type: inductive cos phi = 0.4 configurable relay logic 5 A at 30 V DC - load type: resistive L/R = 0 ms configurable relay logic 5 A at 250 V AC - load type: resistive cos phi = 1 configurable relay logic
Discrete input number	6
Discrete input type	Safety input (PWR) at 24 V DC <= 30 V 1.5 kOhm Switch-configurable (LI6) at 24 V DC <= 30 V level 1 PLC 1.5 kOhm (duration=1.5...2.5 ms) Programmable (LI1...LI4) at 24 V DC <= 30 V level 1 PLC 3.5 kOhm (duration=1.5...2.5 ms)
Discrete input logic	Positive logic (source) (PWR) voltage (state 0): 0...2 V voltage (state 1): 17...30 V Negative logic (sink) (LI1...LI6) voltage (state 0): 16...30 V voltage (state 1): 0...10 V Positive logic (source) (LI1...LI6) voltage (state 0): 0...5 V voltage (state 1): 11...30 V
Acceleration and deceleration ramps	Linear adjustable separately from 0.01 to 9000 s S, U or customized
Braking to standstill	By regenerative braking with active front end
Protection type	Motor phase break for motor Thermal protection for motor Short-circuit between motor phases for drive Power removal for drive Overvoltages on the DC bus for drive Overheating protection for drive Overcurrent between output phases and earth for drive Line supply undervoltage for drive Line supply overvoltage for drive Against input phase loss for drive Against exceeding limit speed for drive
Dielectric strength	5092 V DC between control and power terminals 3535 V DC between earth and power terminals
Insulation resistance	> 1 mOhm at 500 V DC for 1 minute to earth

Frequency resolution	0.1 Hz for display unit 0.024/50 Hz for analog input
Communication port protocol	CANopen Modbus
Type of connector	Male SUB-D 9 on RJ45 - communication protocol: CANopen 1 RJ45 - communication protocol: Modbus on terminal 1 RJ45 - communication protocol: Modbus on front face
Physical interface	2-wire RS 485 - communication protocol: Modbus
Transmission frame	RTU - communication protocol: Modbus
Transmission rate	20 kbps, 50 kbps, 125 kbps, 250 kbps, 500 kbps, 1 Mbps - communication protocol: CANopen 9600 bps, 19200 bps - communication protocol: Modbus on front face 4800 bps, 9600 bps, 19200 bps, 38.4 Kbps - communication protocol: Modbus on terminal
Data format	8 bits, odd even or no configurable parity - communication protocol: Modbus on terminal 8 bits, 1 stop, even parity - communication protocol: Modbus on front face
Type of polarization	No impedance - communication protocol: Modbus
Number of addresses	1...247 - communication protocol: Modbus 1...127 - communication protocol: CANopen
Method of access	Slave - communication protocol: CANopen
Function available	Isolated amplifier for control circuit Adaptor for 115 V logic inputs for control circuit Control terminals for control circuit External 24 V DC supply terminals for power circuit Relay output C/O for control circuit Enclosure plinth for power circuit Cable entry via the top for power circuit Motor choke for power circuit Enclosure heating for power circuit Ammeter for power circuit Door handle for main switch for power circuit Voltmeter for power circuit External motor fan for power circuit Motor heating for power circuit Key switch (local/remote) for power circuit Enclosure lighting for power circuit Buffer voltage 24 V DC power supply for power circuit External 230 V supply terminals for power circuit Design for IT networks for power circuit Insulation monitoring for power circuit Pt100 relay for power circuit PTC relay for power circuit Safe standstill for power circuit
Option card	Encoder interface cards Extended I/O extension card Basic I/O extension card Controller inside programmable card Communication card - communication protocol: Profibus DP V1 Communication card - communication protocol: Profibus DP Communication card - communication protocol: Modbus/Uni-Telway Communication card - communication protocol: Modbus TCP Communication card - communication protocol: Modbus Plus Communication card - communication protocol: Interbus-S Communication card - communication protocol: Fipio Communication card - communication protocol: Ethernet/IP Communication card - communication protocol: DeviceNet Communication card - communication protocol: CC-Link
Operating position	Vertical +/- 10 degree
Colour of enclosure	Light grey RAL 7035
Width	800 mm
Height	2157 mm
Depth	642 mm
Product weight	605 kg

Environment

IP degree of protection	IP23
Standards	EN 60204-1 EN 61800-3 environments 2 category C3 EN 61800-5-1 EN 61800-2
Product certifications	ATEX C-Tick GOST
Marking	CE
Noise level	69 dB
Pollution degree	2 conforming to EN/IEC 61800-5-1
Vibration resistance	3M3 conforming to EN/IEC 60721-3-3 1.5 mm peak to peak (f=3...10 Hz) conforming to EN/IEC 60068-2-6 0.6 gn (f=10...200 Hz) conforming to EN/IEC 60068-2-6
Shock resistance	3M2 conforming to EN/IEC 60721-3-3 4 gn 11 ms conforming to EN/IEC 60068-2-27
Environmental characteristic	3K3 without condensation conforming to IEC 60721-3-3
Relative humidity	<= 95 %
Ambient air temperature for operation	40...50 °C with current derating of 1.8 % per °C 0...40 °C without derating
Ambient air temperature for storage	-25...70 °C
Volume of cooling air	1200 m ³ /h
Operating altitude	1000...3000 m with current derating 1 % per 100 m <= 1000 m without derating

Dimensions

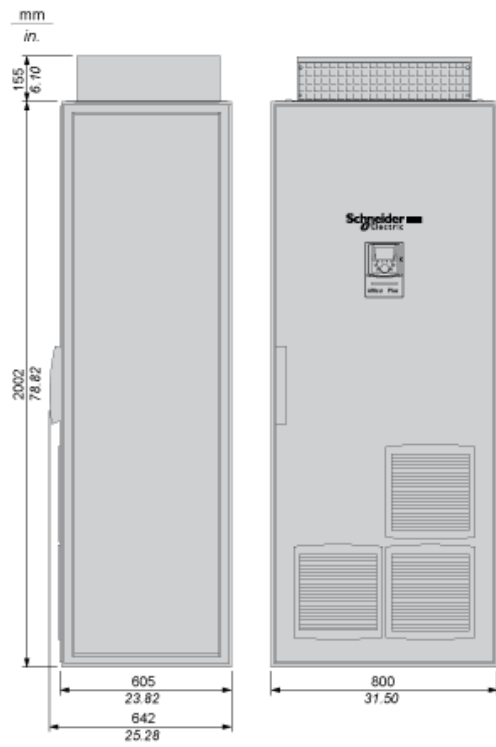

Wiring Diagram

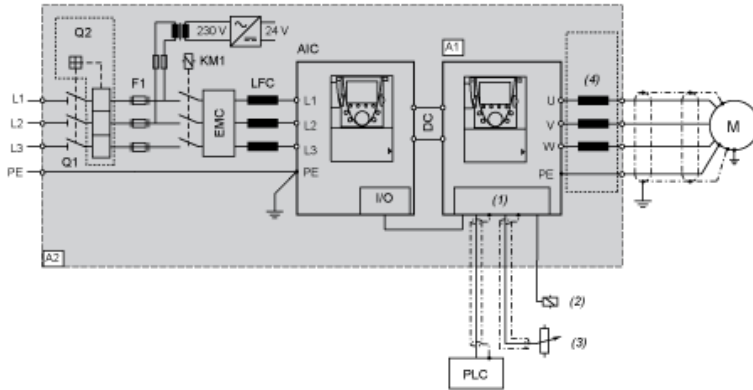

- A1 Drive
- A2 Enclosure
- AIC Active Infeed Converter
- M Motor
- Q1 Main switch built-in as standard
- Q2 Optional circuit breaker
- F1 Main fuses
- KM1 Line contactor
- EMC EMC filter
- LFC Line Filter Choke
- (1) Control
- (2) Relay control
- (3) Reference potentiometer
- (4) Option motor choke

Derating Curves

The derating curves for the drive nominal current (I_n) are dependent on the temperature and switching frequency. For intermediate temperatures, interpolate between 2 curves.

NOTE: The drive will reduce the switching frequency automatically in the event of excessive temperature rise.

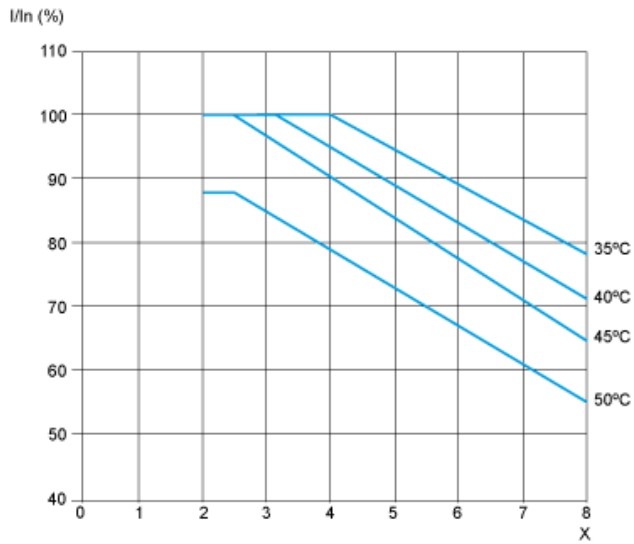

X Switching frequency (kHz)

NOTE: The temperatures shown correspond to the temperature of the air entering the enclosure.