

MOSA M12 FEMALE 90° 3LED (IDC) V2A4-pol. 0.25...0.5mm²

F&B

Female 90°

M12, 4-pole

3× LED (PNP)

IDC terminals

Connection cross section: 0.25...0.5 mm²

V2A nut/screw

Plastic housings with good resistance against chemicals and oils.

The resistance to aggressive media should be individually tested for your application. Further details on request.

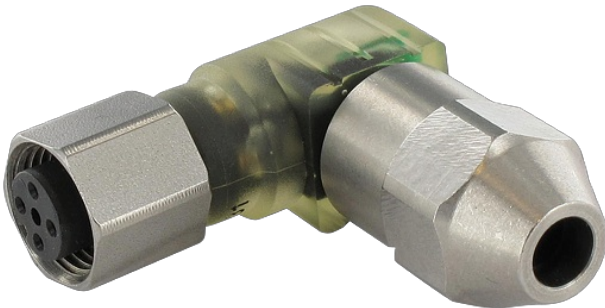
[Link to Product](#)**Illustration**

Female

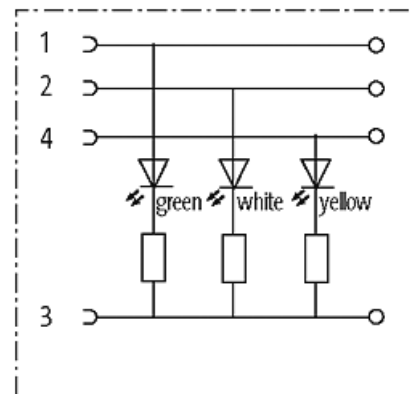
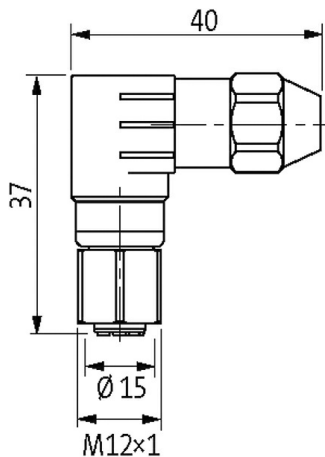
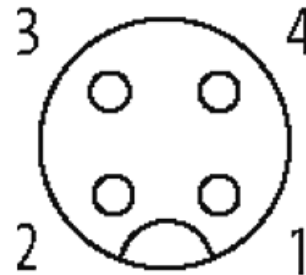

Product may differ from Image

Form

Form 12691

Technical Data

Operating voltage	24 V AC/DC ±25%
Operating current per contact	max. 4 A
Connection cross section	0.25...0.5 mm ² (conductor diameter min. 0.1 mm)
Sealing range (cable Ø)	4...5.1 mm
Wire isolation	PVC, PP, TPE

Outer wire Ø	1.2...1.6 mm
Locking of ports	Screw thread (M12×1 mm) recommended torque 0.6 Nm, self-securing
Protection	IP67 inserted and tightened (EN 60529)
Locking material	Stainless steel 1.4305 (V2A)

General data

Temperature range	-25...+85 °C
-------------------	--------------

Commercial data

country of origin	DE
customs tariff number	85366990
EAN	4048879112079
eClass	27279220
Packaging unit	1