



SmartSolutions™ Expansion Kit

Condition Monitoring and Preventative Maintenance



Validate with data. Provide Savings. Increase Value.

- Sensors with proven wireless connectivity and seamless communication to Cloud Data Services
- Configurable dashboards with default alarms assist in data-driven decisions and solutions
- Out-of-box ready to acquire data in 30 minutes or less
- Mix and Match sensor types to customize the system for your application

The turn-key, essential solution to scale predictive maintenance initiatives

This kit provides the basic platform needed to implement a comprehensive monitoring system for your industrial applications. Easily deploy IIOT solutions for monitoring the health of rotating machines, material levels, pressurized systems, and many other aspects of your operation with one system and a few short minutes for setup and installation. Unlock insights into your processes with the Banner Cloud Data Services platform and industrial grade products. Create Dashboards and Alerts that help automate the maintenance checks inside your facility.

Kit includes:



Wireless Gateway



Prepaid Banner Cloud Data Services

Sold Separately:



Banner Wireless Sensors

SmartSolutions™ Expansion Kit Series

Scale Your IIoT System with Banner

Kit Features:

- Connect a total of 40 sensor nodes for your specific application needs
- Preconfigured gateway provides time-saving Direct-to-Cloud functionality
- Wireless Gateway options rated for indoor and outdoor (IP67) applications
- Proven secure and reliable communications between sensors and the gateway
- 900 MHz ISM Radio for up to 50 times larger range than Bluetooth
- On-board display for wireless sensor network commissioning

Acquire insights with one Direct-to-Cloud Solution

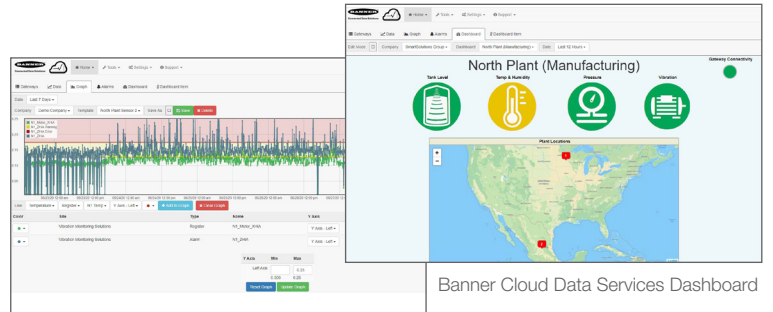

Banner Cloud Data Services Dashboard

The SmartSolutions™ Expansion Kit Series

Designed to enable owners of assets and processes to obtain actionable insights that will solve industrial challenges delivered in a robust and easily deployable solution. From high-grade sensing hardware and gateways, to trusted network connectivity and intuitive software, the SmartSolutions™ Expansion Kit Series provides the nexus of technologies needed to evaluate and scale the Industrial Internet of Things (IIoT) within an enterprise.

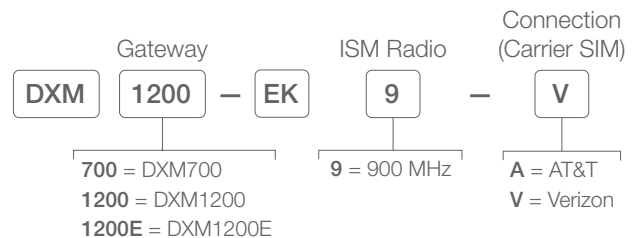

"This helped us scale our preventative maintenance program quickly! We captured the ROI within days of implementation."

Bruce G. - Plant Manager

Designed to get up to speed quickly and scale with ease

The SmartSolutions™ Expansion Kit can deliver value in minutes, not hours or days. Add any industrial grade All-In-One Sensor Node to the Expansion Kit and adapt the system for the specific requirements of the application or facility.

Wireless Gateways



DXM1200 (Sealed)



DXM700

All-in-One Sensor Nodes



Vibration



Temp/ Humidity



Tank Level



Pressure



Differential Pressure



Temp Probe



Dual Temp Probe



Current Sensor

DXM1200 Expansion Kit

Banner's Wireless Gateway is an industrial wireless device that facilitates Industrial Internet of Things (IIoT) applications. As a communications gateway, it offers seamless connectivity by hosting a robust ISM radio network for local wireless devices used to acquire and transmit data from assets within the industrial environment. The intuitive on-board display is used to bind the nodes to the wireless network and the device arrives preconfigured for ethernet communication to Banner Cloud Data Services.

- ISM local radio network in 900 MHz frequency band
- Equipped with IP67-rated housing for use in challenging environments
- 24 V DC Power Supply included within SmartSolutions™ Expansion Kit
- Embedded cellular device provides optional connection to Verizon or AT&T carriers
- Internal radio and cellular antennas ensure reliable data transmission in all conditions
- Use default Ethernet connection or enable Cellular Data Services in minutes



Models	Description
DXM1200-EK9-V	ISM 900 MHz Radio; preconfigured device detection and ethernet communication; Verizon cellular module & SIM included
DXM1200-EK9-A	ISM 900 MHz Radio; preconfigured device detection and ethernet communication; AT&T cellular module & SIM included

Specifications

Supply Voltage	12 to 30 V DC (use only with a suitable Class 2 power supply (UL) or a Limited Power Source (LPS) (CE) power supply)
Construction	Polycarbonate
Environmental Rating	IEC IP67
Operating Conditions	-20 to +60 °C (-4 to +140 °F)
Security Protocol	TLS, SSL, HTTPS
Push to Cloud Rate	Once every 5 minutes (ethernet connection) [default] Once every 10 minutes (cellular connection)
900 MHz Compliance	FCC ID UE3RM1809: FCC Part 15, Subpart C, 15.247 IC: 7044A-RM1809 IFT: RCPBARM13-2283
Certifications	

Support Literature

216539	Sure Cross® DXM1200-Bx Wireless Controller Instruction Manual
196719	Sure Cross® DXM1200-Bx Wireless Controller Datasheet

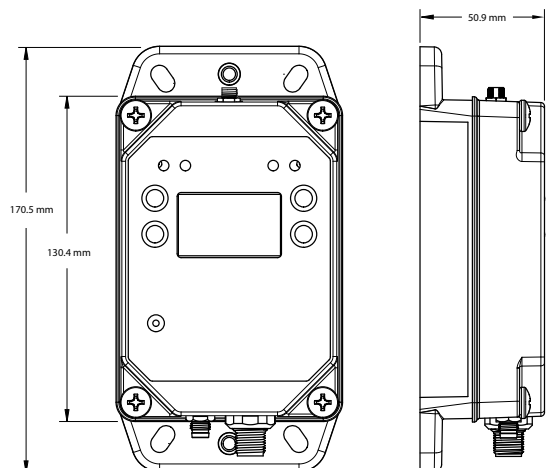

Sensor Nodes to Customize your Expansion Kit

Use the simple binding process to join up to 40 sensor nodes per Gateway that monitor tank level, ambient temperature and humidity, the health of rotating machines and pressurized systems.

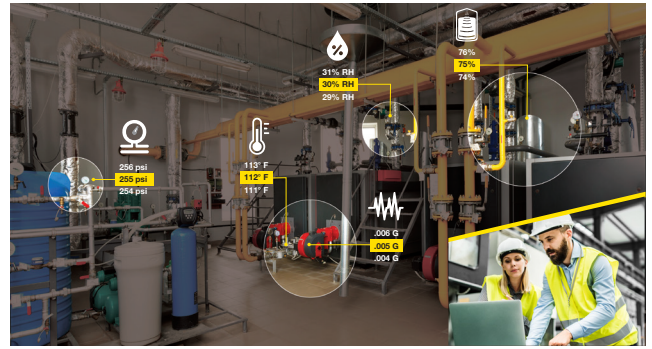

Banner Engineering has hundreds of sensor solutions to meet your needs. Please visit BannerEngineering.com to discover the right solution for your specialized applications.



All-in-One Vibration Sensor Node

Models	Radio Frequency	Power Supply	Inputs & Outputs
DX80N9Q45VAC	900 MHz ISM Band	C Cell Lithium Battery	Vibration and temperature detection



Wireless Node and Compact Vibration Sensor (must be purchased together)

Models	Communication	Radio Frequency	Inputs
DX80N9Q45VTP	ISM Radio Band	900 MHz	Vibration and temperature detection
QM30VT1	1-Wire Serial	–	



All-in-One Temperature and Humidity Sensor Node

Models	Radio Frequency	Measurement Range	Inputs
DX80N9Q45THA	900 MHz ISM Band	–40 to +85 °C (–40 to +185 °F) 0 to 100% Relative Humidity	Temperature and relative humidity (%)



All-in-One Temperature Probe Sensor Node

Models	Radio Frequency	Measurement Range	Inputs
DX80N9Q45TA	900 MHz ISM Band	–20 to +105 °C (–4 to +221 °F)	Temperature



All-in-One Dual Temperature Probe Sensor Node

Models	Radio Frequency	Measurement Range	Inputs
DX80N9Q45DT	900 MHz ISM Band	–20 to +105 °C (–4 to +221 °F)	Temperature

Sensor Nodes to Customize your Expansion Kit (continued)



All-in-One Ultrasonic Sensor Node

Models	Radio Frequency	Ultrasonic input Range and Frequency	Inputs
DX80N9Q45UAA	900 MHz ISM Band	Range: 100 mm to 1 m (3.94 in to 39.4 in) Frequency: 240 kHz	Inputs: One Ultrasonic Input One Thermistor Input
DX80N9Q45UAC	900 MHz ISM Band	Range: 300 mm to 3 m (11.8 in to 118 in) Frequency: 114 kHz	



Wireless Node and Quick-Disconnect Pressure Sensor (must be purchased together)

Models	Radio Frequency	Pressure Range	Inputs
DX80N9Q45UPSD	900 MHz ISM Band	Universal	Pressure
BWA-PRESSURE-SENSOR-15	1 Wire Serial	0-15 PSI	
BWA-PRESSURE-SENSOR-50	1 Wire Serial	0-50 PSI	
BWA-PRESSURE-SENSOR-150	1 Wire Serial	0-150 PSI	
BWA-PRESSURE-SENSOR-500	1 Wire Serial	0-500 PSI	
BWA-PRESSURE-SENSOR-3000	1 Wire Serial	0-3000 PSI	



All-in-One Differential Pressure Sensor Node

Models	Radio Frequency	Pressure Range	Inputs
DX80N9Q45DPSD1	900 MHz ISM Band	±2 inches of water column	Low pressure differential sensor
DX80N9Q45DPSD20	900 MHz ISM Band	±20 inches of water column	



All-in-One Current Sensor Node

Models	Radio Frequency	Measurement Range	Inputs
DX80N9Q45CT	900 MHz ISM Band	0-20 Amps or 0-150 Amps	Amperage (Two Current Transformers Included)