

Sure Cross® DXM700-B1 and DXM700-B2 Wireless Controller



Datasheet

The DXM700-Bx Wireless Controller is an industrial wireless controller that facilitates Industrial Internet of Things (IIoT) applications. As a communications gateway, it interfaces local serial ports, local I/O ports, and local ISM radio devices to the Internet using a cellular connection or wired Ethernet network connection.

- **High Performance Wireless Communication**—Uses Sure Cross® DX80 Wireless Gateway or MultiHop radio with 900 MHz or 2.4 GHz ISM bands available for long range communication
- **Flexible and Customizable**—Expanded internal logic controller with action rules and ScriptBasic programming capable of developing simple or complex solutions to process, log, and control data to/from multiple wireless radios and sensors
- **Improved Speed and Memory**—Upgraded internal processor to use 2850 32-bit integer registers, 2000 floating-point registers, and 1050 non-volatile 32-bit integer registers; expanded ScriptBasic programming capability for faster script processing and ability to build more complex solutions with scripts



- **External Communications**—Cellular modem Internet connectivity
- **Compact Size**—Reduced size of 70 mm to consume less space on a DIN rail
- **Simple Sourcing Outputs**—Four PNP outputs (100 mA max at 30 V DC) available for local triggers
- **Industry Compatibility**—Automation protocols include Modbus/TCP, Modbus RTU, and EtherNet/IP™ for communications between PLCs, HMIs, or other local hosts.
- **Customizable Alerts**—Secure email for alarms and alerts
- Data logged to a removable SD card or sent via email
- Interactive programmable user interface with LCD and LED indicators
- Industry standard RS-485, Ethernet, and USB communication ports

Models

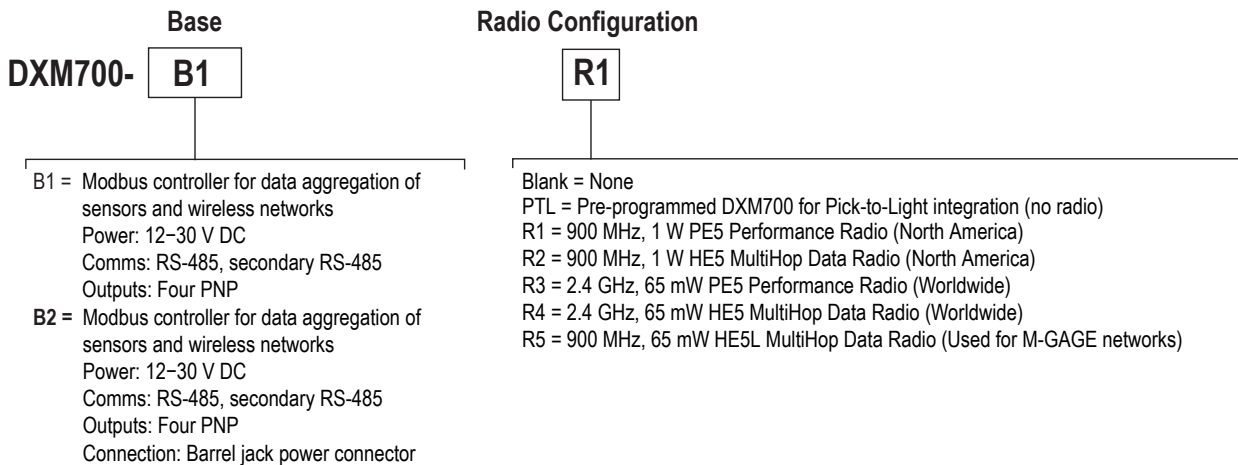

Some example models include, but are not limited to, the following:

Models	Description
DXM700-B1R1	DXM700-B1 Wireless Controller with DX80 ISM 900 MHz Performance radio
DXM700-B1R2	DXM700-B1 Wireless Controller with DX80 ISM 900 MHz MultiHop radio
DXM700-B1R3	DXM700-B1 Wireless Controller with DX80 ISM 2.4 GHz Performance radio
DXM700-B1R4	DXM700-B1 Wireless Controller with DX80 ISM 2.4 GHz MultiHop radio
DXM700-B1R5	DXM700-B1 Wireless Controller with DX80 ISM 900 MHz MultiHop 100mW radio
DXM700-B2R1	DXM700-B2 Wireless Controller with DX80 ISM 900 MHz Performance radio
DXM700-B2R3	DXM700-B2 Wireless Controller with DX80 ISM 2.4 GHz Performance radio

Cellular Communication—Controllers accept Banner LTE (United States) and GSM (outside the United States) modems only. Cellular modems are ordered separately as accessories under the following part numbers:

Table 1: Cellular modem kit models

Cellular Kit Model	Kit Description
SXI-LTE-001	Verizon LTE cellular modem using Telit LE910 modem kit (Verizon part number SENSX002). Includes a cellular modem, SIM card, antenna, and antenna cable. The SIM card is specific to the LTE technology and cannot be used in other cellular modems. Requires a LTE Verizon cellular wireless plan attached to the ICCID (SIM card) number and IMEI (International Mobile Equipment Identity) number. Cellular plans can be purchased through secure.bannercelldata.com .



Cellular Kit Model	Kit Description
SXI-CATM1VZW-001	Verizon CAT M1 cellular modem using Telit ME910 modem kit (Verizon part number SXIM1V). Includes a cellular modem, SIM card, and internal adhesive antenna. The SIM card is specific to the CATM1 technology and cannot be used in other cellular modems. Requires a LTE Verizon cellular wireless plan attached to the ICCID (SIM card) number and IMEI (International Mobile Equipment Identity) number. Cellular plans can be purchased through secure.bannercelldata.com .
SXI-CATM1ATT-001	ATT CAT M1 cellular modem using Telit ME910 model kit. (ATT part number SXIM1A). Includes a cellular modem, SIM card, and internal adhesive antenna. The SIM card is specific to the CATM1 technology and cannot be used in other cellular modems. Requires a LTE AT&T cellular wireless plan attached to the ICCID (SIM card) number and IMEI (International Mobile Equipment Identity) number. Cellular plans can be purchased through secure.bannercelldata.com .

DXM700 Documentation

- DXM Wireless Controller Sell Sheet, p/n [194063](#)
- DXM700-B1 and DXM700-B2 Wireless Controller Datasheet, p/n [207893](#)
- DXM700-Bx Wireless Controller Instruction Manual, p/n [207894](#)
- DXM ScriptBasic Instruction Manual, p/n [191745](#)
- DXM Controller Configuration Quick Start, p/n [191247](#)
- DXM Configuration Software v4 (p/n [b_4496867](#))
- DXM Configuration Software Instruction Manual, p/n [209933](#)
- DXM EDS [Configuration file](#) for Allen-Bradley PLCs
- EIP Configuration File for DXM7xx-BxR1 and R3 models (p/n [209068](#))
- Activating a Cellular Modem (p/n [b_4419353](#))
- Additional technical notes and videos

For more information about the DXM700 family of products, including technical notes, configuration examples, and ScriptBasic program examples, please refer to the Banner website: www.bannerengineering.com

DXM700-Bx System Overview

Banner's DXM Logic Controller integrates Banner's wireless radio, cellular connectivity, and local I/O to provide a platform for the Industrial Internet of Things (IIoT).

Figure 1. DXM700 system overview

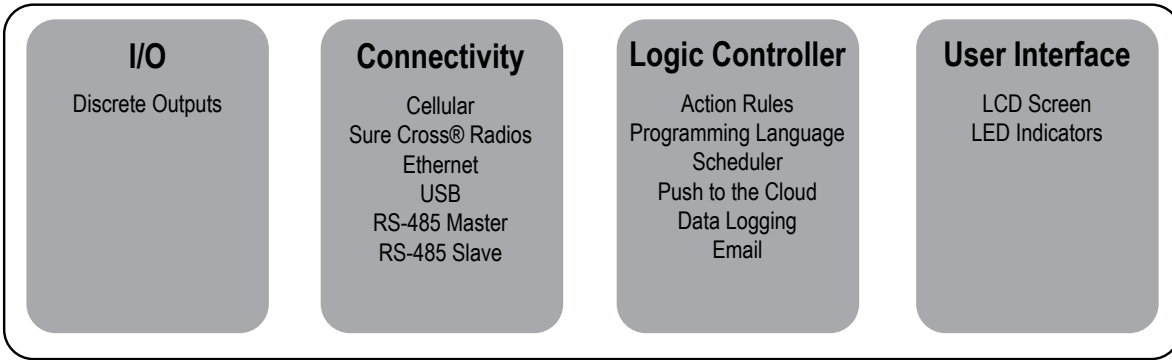

Table 2: Modbus registers for internal local registers (Modbus slave ID 199)

Local Registers	Type	Description
1–845	32-bit integer	Local data registers
846–849	32-bit integer	Reset, Constant, Timer
851–900	32-bit non-volatile integer	Data flash, non-volatile
901–1000		Reserved for internal use
1001–5000	Floating point	Floating point registers, local data registers
5001–7000	32-bit integer	Local data registers
7001–8000	32-bit non-volatile integer	Data flash, non-volatile
> 10000		Read only virtual registers, system-level data

Outputs—Four discrete PNP outputs (supply voltage minus 2 V, 100mA maximum at 30 V DC)

Connectivity—The DXM700's wired and wireless connectivity options make it easy to share data between local and remote equipment. The cellular modem option eliminates the need for IT infrastructures to connect remote equipment for sensing and control to IIoT cloud services. The integrated Sure Cross® wireless radio enables Modbus connectivity to remote sensors, indicators, and control equipment.

Wired Connectivity

- Ethernet: Modbus/TCP (master/slave) or Ethernet/IP
- Field Bus: Modbus RS-485 Master/Slave

Wireless Connectivity

- Sure Cross Wireless Radio: DX80 900 MHz, DX80 2.4 GHz, MultiHop 900 MHz, or MultiHop 2.4 GHz
- Cellular modem: LTE (United States only) or GSM (Outside the United States)

Logic Controller—Program the DXM700's logic controller using action rules and/or ScriptBasic language, which can execute concurrently. The control functions allow freedom when creating custom sensing and control sequences. The logic controller supports the Modbus protocol standards for data management, ensuring seamless integration with existing automation systems. File and LCD password protection is an option.

Register Mapping

- Cyclical Read rules from wireless devices or local wired Modbus devices that include optional scaling, error conditions, and the ability to activate a read rule
- Cyclical or Change of State Write rules to wireless devices or local wired Modbus devices with scaling
- Modbus/TCP Master Read or Write rules for external devices on the network

Action Rules

- Thresholds (IF/THEN/ELSE) with timers, minimum on/off time, and logging options
- Math/Logic Rules (arithmetic and bitwise operators)
- Control Logic (logical operators and SR/T/D/JK flip flops)
- Trending (multiple averaging filters)
- Tracking (counts, on/off times)
- Email notifications
- Push data on conditions

User Interface— A simple user interface consists of an LCD screen and four LED indicators.

User programmable LCD

- Bind Sure Cross radios
- Conduct a site survey to evaluate the radio signal integrity of radios within the network
- View register and output information
- View system status and configuration

Scheduler

- Time/calendar-based events
- Holiday skips
- One-time events
- Dynamic scheduler updating
- Astronomical clock

Optional Text Programming Language

- ScriptBasic to create variables, arrays, functions, loops, IF/THEN/ELSE, logical and arithmetic operators, API commands, register access, string functions and operators, time commands

Data Logging

- Cyclic data/event logging
- Email log files

API Interface

- Host Initiated control
- Web service integration

User Defined LED indicators

- Indicates the status of the DXM700, processes, or equipment

Applications Overview

The DXM700 is ideal for smart factory and facilities applications, including:

- Productivity solutions, such as
 - Call for parts, service, or maintenance
 - Pick-to-light
 - OEE Tower light monitoring
- Predictive maintenance and continuous monitoring using
 - Vibration and temperature monitoring
 - Tank level monitoring
 - Non-contact condition monitoring
- Environmental monitoring and control, such as
 - Temperature and humidity monitoring

The DXM700 can provide visual indication using indicator lights, send email alerts, collect data, and interface with automation systems.

Specifications

Radio Specifications

Radio Range [¶]

900 MHz, 1 Watt: Up to 9.6 km (6 miles)
2.4 GHz, 65 mW: Up to 3.2 km (2 miles)

Antenna Minimum Separation Distance

900 MHz, 150 mW and 250 mW: 2 m (6 ft)
900 MHz, 1 Watt: 4.57 m (15 ft)
2.4 GHz, 65 mW: 0.3 m (1 ft)

Radio Transmit Power

900 MHz, 1 Watt: 30 dBm (1 W) conducted (up to 36 dBm EIRP)
2.4 GHz, 65 mW: 18 dBm (65 mW) conducted, less than or equal to 20 dBm (100 mW) EIRP

Spread Spectrum Technology

FHSS (Frequency Hopping Spread Spectrum)

Link Timeout (Performance)

Gateway: Configurable via User Configuration Software
Node: Defined by Gateway

Antenna Connection

Ext. Reverse Polarity SMA, 50 Ohms
Max Tightening Torque: 0.45 N-m (4 lbf-in)

Radio Packet Size (MultiHop)

900 MHz: 175 bytes (85 Modbus registers)
2.4 GHz: 75 bytes (37 Modbus registers)

900 MHz Compliance (1 Watt)

Contains FCC ID: UE3RM1809: FCC Part 15, Subpart C, 15.247
Contains IC: 7044A-RM1809
IFT: RCPBARM13-2283



(NOM approval only applies to 900 MHz models)

2.4 GHz Compliance (DX80-2400 Radio Module)

Radio module is indicated by the product label marking
Contains FCC ID: UE300DX80-2400: FCC Part 15, Subpart C, 15.247
Radio Equipment Directive (RED) 2014/53/EU
Contains IC: 7044A-DX8024

ANATEL: 15966-21-04042 Este equipamento não tem direito à proteção contra interferência prejudicial e não pode causar interferência em sistemas devidamente autorizados. Para maiores informações, consulte o site da ANATEL www.gov.br/anatel/pt-br/

2.4 GHz Compliance (SX243 Radio Module)

Radio module is indicated by the product label marking
Contains FCC ID: UE3SX243: FCC Part 15, Subpart C, 15.247
Radio Equipment Directive (RED) 2014/53/EU
Contains IC: 7044A-SX243

[¶] Radio range is with the 2 dB antenna that ships with the product. High-gain antennas are available, but the range depends on the environment and line of sight. Always verify your wireless network's range by performing a Site Survey.

Power and I/O Specifications

Supply Voltage

12 to 30 V DC (use only with a suitable Class 2 power supply (UL) or a Limited Power Source (LPS) (CE) power supply)

Power Consumption

35 mA average at 12 Volts (exclusive of load)

Logging

8 GB maximum; removable Micro SD card format

Security Protocols

VPN, SSL, and HTTPS

Power Connections

DXM700-B1: Wiring terminals
DXM700-B2: Barrel jack

Certifications



Banner Engineering Europe
Park Lane, Culliganlaan 2F bus
3, 1831 Diegem, BELGIUM

(CE/UKCA approval
only applies to 2.4
GHz models)



Turck Banner LTD Blenheim
House, Blenheim Court,
Wickford, Essex SS11 8YT,
Great Britain



เครื่องวิทยุคมนาคมนี้ ได้รับยกเว้น ไม่ต้องได้
รับใบอนุญาตให้มี ใช้งานเครื่องวิทยุคมนาคม
หรือตั้งสถานีวิทยุคมนาคมตามประกาศ กสทช.
เรื่อง เครื่องวิทยุคมนาคม และสถานีวิทยุ
คมนาคมที่ได้รับยกเว้นไม่ต้องได้รับใบอนุญาต
วิทยุคมนาคมตามพระราชบัญญัติวิทยุคมนาคม
พ.ศ. 2498

nano | โทรคมนาคม
สำนักงานส่งเสริมวิสาหกิจขนาดกลางและขนาดย่อม
Call Center 1200 (ฟรีWiFi)

เครื่องโทรคมนาคมและอุปกรณ์นี้
มีความสอดคล้องตามมาตรฐาน
หรือข้อกำหนดทางเทคนิคของ
กสทช. (Approval only
applies to the
DXM700-B1R4
model)

Construction

Polycarbonate; DIN rail mount option

Communication Protocols

Modbus RTU Master/Slave, Modbus/TCP, and Ethernet/IP

Discrete Outputs

Four, PNP/Sourcing
Update Rate: 125 milliseconds
ON Condition: Supply minus 2 V
OFF Condition: Less than 2 V

Discrete Output Rating (PNP)

100 mA max current at 30 V DC
ON-State Saturation: Less than 3 V at 100 mA
OFF-state Leakage: Less than 10 μ A

Required Overcurrent Protection



WARNING: Electrical connections must be made by qualified personnel in accordance with local and national electrical codes and regulations.

Overcurrent protection is required to be provided by end product application per the supplied table. Overcurrent protection may be provided with external fusing or via Current Limiting, Class 2 Power Supply. Supply wiring leads < 24 AWG shall not be spliced. For additional product support, go to www.bannerengineering.com.

Supply Wiring (AWG)	Required Overcurrent Protection (Amps)
20	5.0
22	3.0
24	2.0
26	1.0
28	0.8
30	0.5

Modbus® is a registered trademark of Schneider Electric USA, Inc.

RS-485 Communication Specifications

Communication Hardware (MultiHop RS-485)

Interface: 2-wire half-duplex RS-485

Baud rates: 9.6k, 19.2k (default), or 38.4k via DIP switches; 1200 and 2400 via the MultiHop Configuration Software

Data format: 8 data bits, no parity, 1 stop bit

Environmental Specifications

Operating Conditions²

-20 °C to +60 °C (-4 °F to +140 °F)

95% maximum relative humidity (non-condensing)

Radiated Immunity: 10 V/m (EN 61000-4-3)

Shock and Vibration

All models meet IEC 60068-2-6 and IEC 60068-2-27 testing criteria

Shock: 30G 11 ms duration, half sine wave per IEC 60068-2-27

Vibration: 10 Hz to 55 Hz, 0.5 mm peak-to-peak amplitude per IEC 60068-2-6

Environmental Rating

IP20

² Operating the devices at the maximum operating conditions for extended periods can shorten the life of the device.

Dimensions

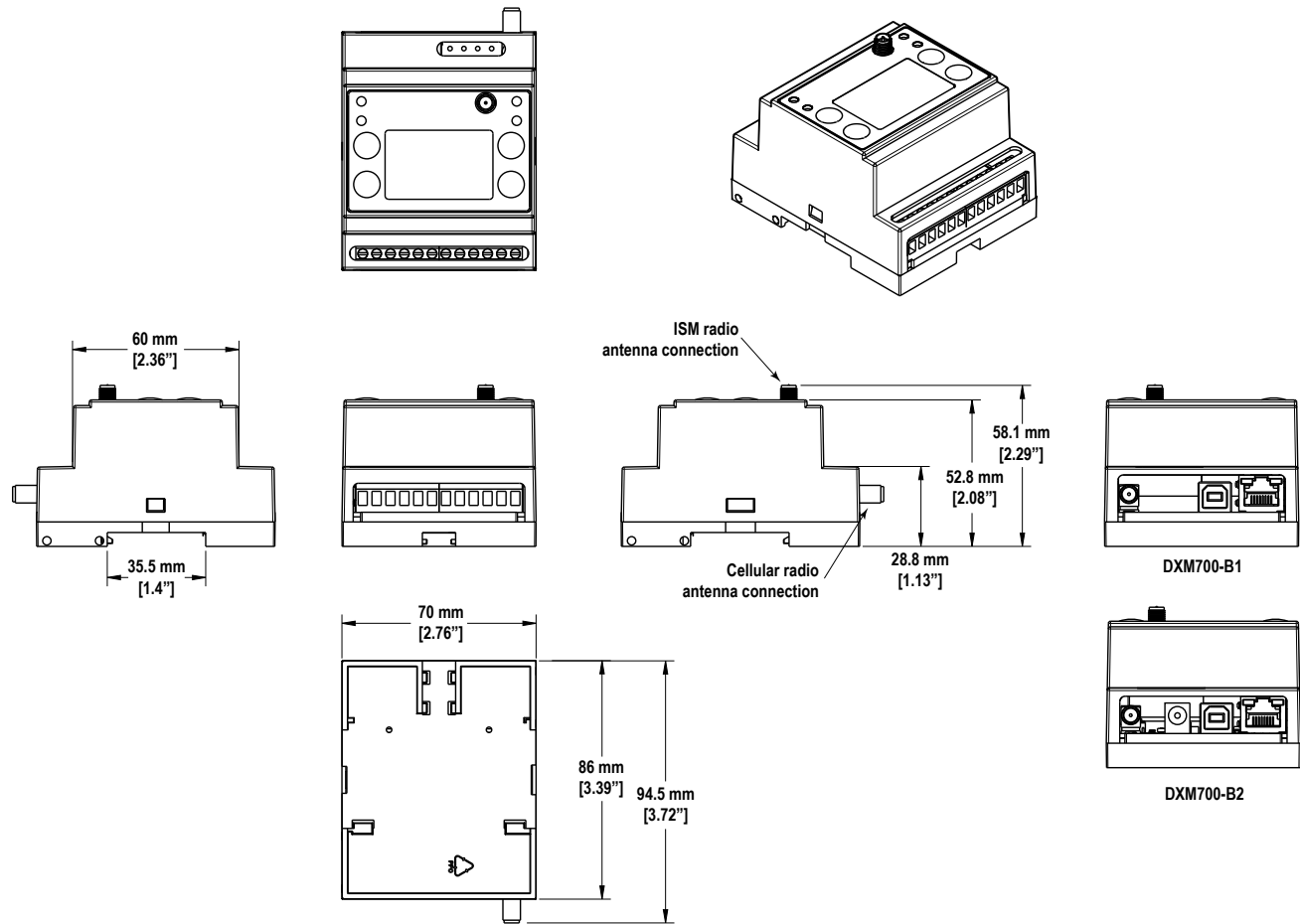

All measurements are listed in millimeters [inches], unless noted otherwise.

Accessories

For a complete list of all the accessories for the Sure Cross wireless product line, please download the Accessories List (p/n [b_3147091](#)).

Cordsets

- MQDC1-506—5-pin M12, straight, single ended, 6 ft
- MQDC1-530—5-pin M12, straight, single ended, 30 ft
- MQDC1-506RA—5-pin M12, right-angle, single ended, 6 ft
- MQDC1-530RA—5-pin M12, right-angle, single ended, 30 ft

Static and Surge Suppressor

- BWC-LFNBMN-DC—Surge Suppressor, bulkhead, N-Type, DC Blocking, N-Type Female, N-Type Male

Short-Range Omni Antennas

- BWA-2O2-D—Antenna, Dome, 2.4 GHz, 2 dBi, RP-SMA Box Mount
- BWA-9O2-D—Antenna, Dome, 900 MHz, 2 dBi, RP-SMA Box Mount
- BWA-9O2-RA—Antenna, Rubber Fixed Right Angle, 900 MHz, 2 dBi, RP-SMA Male Connector

Medium-Range Omni Antennas

- BWA-9O5-C—Antenna, Rubber Swivel, 900 MHz 5 dBi, RP-SMA Male Connector
- BWA-2O5-C—Antenna, Rubber Swivel, 2.4 GHz 5 dBi, RP-SMA Male Connector

Enclosures and DIN Rail Kits

- BWA-AH864—Enclosure, Polycarbonate, with Opaque Cover, 8 x 6 x 4
- BWA-AH1084—Enclosure, Polycarbonate, with Opaque Cover, 10 x 8 x 4
- BWA-AH12106—Enclosure, Polycarbonate, with Opaque Cover, 12 x 10 x 6
- BWA-AH8DR—DIN Rail Kit, 8", 2 trilobular/self-threading screws
- BWA-AH10DR—DIN Rail Kit, 10", 2 trilobular/self-threading screws
- BWA-AH12DR—DIN Rail Kit, 12", 2 trilobular/self-threading screws

Misc Accessories

- BWA-CG.5-3X5.6-10—Cable Gland Pack: 1/2-inch NPT, Cordgrip for 3 holes of 2.8 to 5.6 mm diam, 10 pack
- BWA-HW-052—Cable Gland and Vent Plug Pack: includes 1/2-inch NPT gland, 1/2-inch NPT multi-cable gland, and 1/2-inch NPT vent plug, one each

Antenna Cables

- BWC-1MRSMN05—LMR200 RP-SMA to N-Type Male, 0.5 m
- BWC-2MRFSRS6—LMR200, RP-SMA Male to RP-SMA Female Bulkhead, 6 m
- BWC-4MNFN6—LMR400 N-Type Male to N-Type Female, 6 m

Long-Range Omni Antennas

- BWA-9O8-AS—Antenna, Fiberglass, 3/4 Wave, 900 MHz, 8 dBi, N-Type Female Connector
- BWA-2O8-A—Antenna, Fiberglass, 2.4 GHz, 8 dBi, N-Type Female Connector

Long-Range Yagi Antennas

- BWA-9Y10-A—Antenna, 900 MHz, 10 dBd, N-Type Female Connector

Cellular Antenna

- BWA-CELLA-002—Cellular multiband, 2 dBi, RP-SMA male connection, 6.3 inch blade style. Datasheet: [b_4475176](#)

Power Supplies

- PSD-24-4—DC Power Supply, Desktop style, 3.9 A, 24 V DC, Class 2, 4-pin M12/Euro-style quick disconnect (QD)
- PSDINP-24-06—DC power supply, 0.63 Amps, 24 V DC, with DIN Rail Mount, Class I Division 2 (Groups A, B, C, D) Rated
- PSDINP-24-13—DC power supply, 1.3 Amps, 24 V DC, with DIN Rail Mount, Class I Division 2 (Groups A, B, C, D) Rated
- PSDINP-24-25—DC power supply, 2.5 Amps, 24 V DC, with DIN Rail Mount, Class I Division 2 (Groups A, B, C, D) Rated
- PSW-24-1—DC power supply with multi-blade wall plug, 100–240 V AC 50/60 Hz input, 24 V DC 1 A output, UL Listed Class 2, 4-pin female M12 connector
- PSWB-24-1—DC power supply with multi-blade wall plug, 100–240 V AC 50/60 Hz input, 24 V DC 1 A output, UL Listed Class 2, barrel jack connector

Warnings

Install and properly ground a qualified surge suppressor when installing a remote antenna system. Remote antenna configurations installed without surge suppressors invalidate the manufacturer's warranty. Keep the ground wire as short as possible and make all ground connections to a single-point ground system to ensure no ground loops are created. No surge suppressor can absorb all lightning strikes; do not touch the Sure Cross® device or any equipment connected to the Sure Cross device during a thunderstorm.

Exporting Sure Cross® Radios. It is our intent to fully comply with all national and regional regulations regarding radio frequency emissions. **Customers who want to re-export this product to a country other than that to which it was sold must ensure the device is approved in the destination country.** The Sure Cross wireless products were certified for use in these countries using the antenna that ships with the product. When using other antennas, verify you are not exceeding the transmit power levels allowed by local governing agencies. This device has been designed to operate with the antennas listed on Banner Engineering's website and having a maximum gain of 9 dBm. Antennas not included in this list or having a gain greater than 9 dBm are strictly prohibited for use with this device. The required antenna impedance is 50 ohms. To reduce potential radio interference to other users, the antenna type and its gain should be so chosen such that the equivalent isotropically radiated power (EIRP) is not more than that permitted for successful communication. Consult with Banner Engineering Corp. if the destination country is not on this list.



Important: Please download the complete DXM700-Bx Wireless Controller technical documentation, available in multiple languages, from www.bannerengineering.com for details on the proper use, applications, Warnings, and installation instructions of this device.



Important: Por favor descargue desde www.bannerengineering.com toda la documentación técnica de los DXM700-Bx Wireless Controller, disponibles en múltiples idiomas, para detalles del uso adecuado, aplicaciones, advertencias, y las instrucciones de instalación de estos dispositivos.



Important: Veuillez télécharger la documentation technique complète des DXM700-Bx Wireless Controller sur notre site www.bannerengineering.com pour les détails sur leur utilisation correcte, les applications, les notes de sécurité et les instructions de montage.



WARNING:

- **Do not use this device for personnel protection**
- Using this device for personnel protection could result in serious injury or death.
- This device does not include the self-checking redundant circuitry necessary to allow its use in personnel safety applications. A device failure or malfunction can cause either an energized (on) or de-energized (off) output condition.



Important:

- **Never operate a 1 Watt radio without connecting an antenna**
- Operating 1 Watt radios without an antenna connected will damage the radio circuitry.
- To avoid damaging the radio circuitry, never apply power to a Sure Cross® Performance or Sure Cross MultiHop (1 Watt) radio without an antenna connected.



Important:

- **Electrostatic discharge (ESD) sensitive device**
- ESD can damage the device. Damage from inappropriate handling is not covered by warranty.
- Use proper handling procedures to prevent ESD damage. Proper handling procedures include leaving devices in their anti-static packaging until ready for use; wearing anti-static wrist straps; and assembling units on a grounded, static-dissipative surface.

Banner Engineering Corp. Limited Warranty

Banner Engineering Corp. warrants its products to be free from defects in material and workmanship for one year following the date of shipment. Banner Engineering Corp. will repair or replace, free of charge, any product of its manufacture which, at the time it is returned to the factory, is found to have been defective during the warranty period. This warranty does not cover damage or liability for misuse, abuse, or the improper application or installation of the Banner product.

THIS LIMITED WARRANTY IS EXCLUSIVE AND IN LIEU OF ALL OTHER WARRANTIES WHETHER EXPRESS OR IMPLIED (INCLUDING, WITHOUT LIMITATION, ANY WARRANTY OF MERCHANTABILITY OR FITNESS FOR A PARTICULAR PURPOSE, AND WHETHER ARISING UNDER COURSE OF PERFORMANCE, COURSE OF DEALING OR TRADE USAGE.

This Warranty is exclusive and limited to repair or, at the discretion of Banner Engineering Corp., replacement. **IN NO EVENT SHALL BANNER ENGINEERING CORP. BE LIABLE TO BUYER OR ANY OTHER PERSON OR ENTITY FOR ANY EXTRA COSTS, EXPENSES, LOSSES, LOSS OF PROFITS, OR ANY INCIDENTAL, CONSEQUENTIAL OR SPECIAL DAMAGES RESULTING FROM ANY PRODUCT DEFECT OR FROM THE USE OR INABILITY TO USE THE PRODUCT, WHETHER ARISING IN CONTRACT OR WARRANTY, STATUTE, TORT, STRICT LIABILITY, NEGLIGENCE, OR OTHERWISE.**

Banner Engineering Corp. reserves the right to change, modify or improve the design of the product without assuming any obligations or liabilities relating to any product previously manufactured by Banner Engineering Corp. Any misuse, abuse, or improper application or installation of this product or use of the product for personal protection applications when the product is identified as not intended for such purposes will void the product warranty. Any modifications to this product without prior express approval by Banner Engineering Corp will void the product warranties. All specifications published in this document are subject to change; Banner reserves the right to modify product specifications or update documentation at any time. Specifications and product information in English supersede that which is provided in any other language. For the most recent version of any documentation, refer to: www.bannerengineering.com.

For patent information, see www.bannerengineering.com/patents.

FCC Part 15 Class A

This equipment has been tested and found to comply with the limits for a Class A digital device, pursuant to part 15 of the FCC Rules. These limits are designed to provide reasonable protection against harmful interference when the equipment is operated in a commercial environment. This equipment generates, uses, and can radiate radio frequency energy and, if not installed and used in accordance with the instruction manual, may cause harmful interference to radio communications. Operation of this equipment in a residential area is likely to cause harmful interference in which case the user will be required to correct the interference at his own expense.

Industry Canada

7044A-RM1809, 7044A-DX8024, 7044A-SX243—This device contains licence-exempt transmitters(s)/receiver(s) that comply with Innovation, Science and Economic Development Canada's licence-exempt RSS(s). Operation is subject to the following two conditions:

1. This device may not cause interference.
2. This device must accept any interference, including interference that may cause undesired operation of the device.

Cet appareil contient des émetteurs/récepteurs exemptés de licence conformes à la norme Innovation, Sciences, et Développement économique Canada. L'exploitation est autorisée aux deux conditions suivantes:

1. L'appareil ne doit pas produire de brouillage.
2. L'utilisateur de l'appareil doit accepter tout brouillage radioélectrique subi, même si le brouillage est susceptible d'en compromettre le fonctionnement.

Notas Adicionales

Información México: La operación de este equipo está sujeta a las siguientes dos condiciones: 1) es posible que este equipo o dispositivo no cause interferencia perjudicial y 2) este equipo debe aceptar cualquier interferencia, incluyendo la que pueda causar su operación no deseada.

Banner es una marca registrada de Banner Engineering Corp. y podrán ser utilizadas de manera indistinta para referirse al fabricante. "Este equipo ha sido diseñado para operar con las antenas tipo Omnidireccional para una ganancia máxima de antena de 6 dBd y Yagi para una ganancia máxima de antena 10 dBd que en seguida se enlistan. También se incluyen aquellas con aprobación ATEX tipo Omnidireccional siempre que no excedan una ganancia máxima de antena de 6dBd. El uso con este equipo de antenas no incluidas en esta lista o que tengan una ganancia mayor que 6 dBd en tipo omnidireccional y 10 dBd en tipo Yagi, quedan prohibidas. La impedancia requerida de la antena es de 50 ohms."

Antenas SMA	Modelo	Antenas Tipo-N	Modelo
Antena, Omni 902-928 MHz, 2 dBd, junta de caucho, RP-SMA Macho	BWA-902-C	Antena, Omni 902-928 MHz, 6 dBd, fibra de vidrio, 1800mm, N Hembra	BWA-906-A
Antena, Omni 902-928 MHz, 5 dBd, junta de caucho, RP-SMA Macho	BWA-905-C	Antena, Yagi, 900 MHz, 10 dBd, N Hembra	BWA-9Y10-A

Mexican Importer

Banner Engineering de México, S. de R.L. de C.V.
David Alfaro Siqueiros 103 Piso 2 Valle oriente
San Pedro Garza Garcia Nuevo León, C. P. 66269

81 8363.2714

ANATEL

Modelo (Model): DX80-2400—Este equipamento não tem direito à proteção contra interferência prejudicial e não pode causar interferência em sistemas devidamente autorizados. Para maiores informações, consulte o site da ANATEL www.gov.br/anatel/pt-br/



ANATEL: 15966-21-04042