

S15C Analog Current to Modbus Converter



Datasheet



- Compact analog current to Modbus converter that connects to a current source (4 mA to 20 mA) and outputs the value to Modbus registers
- Rugged over-molded design meets IP65, IP67, and IP68
- Connects directly to a sensor or anywhere in-line for ease of use

Model



Modbus Configuration

Modbus Register Address	Description	I/O Range	Comments	Default	Access
IO Data Out					
40001	Analog Data output	0-32768	Current (mA) = Register Value /1000	4000-20000	RO
40002	Alarm State for IO 1 based on Min and Max thresholds defined in Analog In Min Value () and Analog In Max Value()	0..1	0 = Within threshold range 1 = Out of threshold range	-	RO
40003	Status of program	0..2	STATUS_ERROR_TYPE_NO_ERROR = 0 STATUS_ERROR_TYPE_BELOW_MIN = 1 STATUS_ERROR_TYPE_ABOVE_MAX = 2	-	RO
Input_ADC_Config					
41201	Sample interval time	0..65535	0 = Disabled 1 = 10 ms 2..65535 = 5 ms increments	1	RW
FilterConfig					
41202	Takes current ADC value and the last ADC reading and takes the median of the values.	0..1	0 = Median Filter Disabled 1 = Median Filter Enabled	0	RW
Minimum Value					
41204	Minimum analog value for data read	0..31 mA	Must be less than maximum	4 mA	RW
Maximum Value					
41205	Max analog value for data read	1..32 mA	Must be greater than the minimum	20 mA	RW
COMs Settings					
46101	Baud Rate	0 = 9.6k 1 = 19.2k 2 = 38.4k	0 = 9.6k 1 = 19.2k 2 = 38.4k	1	RW
46102	Parity	0 = None 1 = Odd 2 = Even	0 = None 1 = Odd 2 = Even	0	RW
46103	Slave Address	1..247	1 to 247	1	RW



Wiring Diagrams



Male (Gateway)	Female (Sensor)	Pin	Wire Color
		1	Brown
		2	White
		3	Blue
		4	Black



Important: If using a cable to connect the converter to an analog sensor, use of a shielded M12 cable is recommended, with the shield tied to pin 3.

Connecting 2-wire 4 mA to 20 mA Sensors

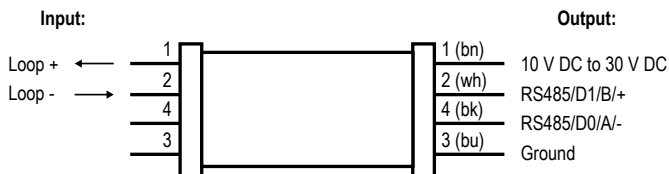

Connecting 3-wire 4 mA to 20 mA Sensors

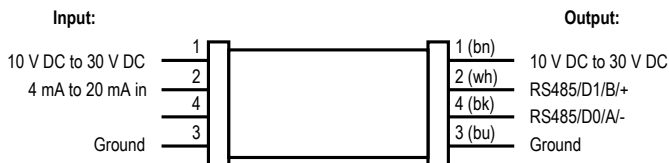

Status Indicators

Power LED Indicator (Green)

- Solid Green = Power On
- Off = Power Off

Modbus Communication LED Indicator (Amber)

- Flashing Amber (4 Hz) = Modbus communications are active
- Solid Amber for 2 seconds to Off = Modbus communications are lost after connection
- Solid Amber for 2 seconds to Flashing Amber (4 Hz) = Modbus communications momentarily lost, but communication reestablished
- Solid Amber = Modbus communications are intermittent, or communications error occurs more frequently than once every 2 seconds
- Off = Modbus communications are not present

Specifications

Supply Voltage

10 V DC to 30 V DC at 50 mA maximum

Power Pass-Through Current

4 A maximum

Supply Protection Circuitry

Protected against reverse polarity and transient voltages

Leakage Current Immunity

400 µA

Resolution

12-bits

Accuracy

1.5% of full scale

Indicators

Green power
Amber Modbus communications

Connections

Integral male/female 4-pin M12 quick disconnect

Construction

Coupling Material: Nickel-plated brass
Connector Body: PVC translucent black

Vibration and Mechanical Shock

Meets IEC 60068-2-6 requirements (Vibration: 10 Hz to 55 Hz, 0.5 mm amplitude, 5 minutes sweep, 30 minutes dwell)
Meets IEC 60068-2-27 requirements (Shock: 15G 11 ms duration, half sine wave)

Certifications



Banner Engineering Europe Park Lane, Culliganlaan 2F bus 3, 1831 Diegem, BELGIUM



Turck Banner LTD Blenheim House, Blenheim Court, Wickford, Essex SS11 8YT, Great Britain



Environmental Rating

IP65, IP67, IP68
NEMA/UL Type 1

Operating Conditions

Temperature: -40 °C to +70 °C (-40 °F to +158 °F)
90% at +70 °C maximum relative humidity (non-condensing)
Storage Temperature: -40 °C to +80 °C (-40 °F to +176 °F)

Required Overcurrent Protection



WARNING: Electrical connections must be made by qualified personnel in accordance with local and national electrical codes and regulations.

Overcurrent protection is required to be provided by end product application per the supplied table.

Overcurrent protection may be provided with external fusing or via Current Limiting, Class 2 Power Supply.

Supply wiring leads < 24 AWG shall not be spliced.

For additional product support, go to www.bannerengineering.com.

Supply Wiring (AWG)	Required Overcurrent Protection (Amps)
20	5.0
22	3.0
24	2.0
26	1.0
28	0.8
30	0.5

Dimensions

All measurements are listed in millimeters [inches], unless noted otherwise.

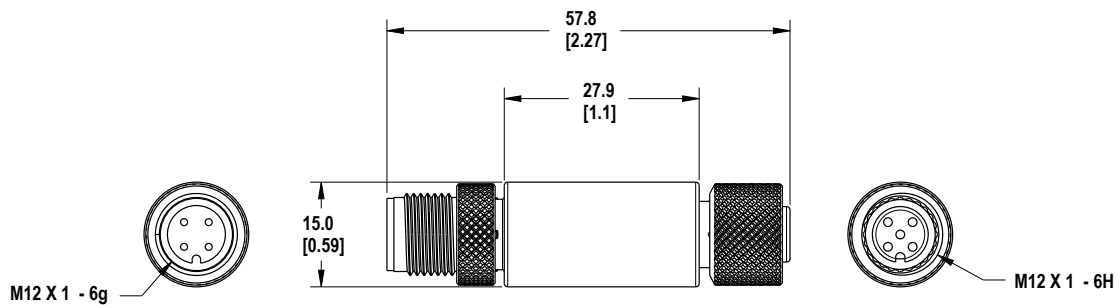

Accessories

Cordsets

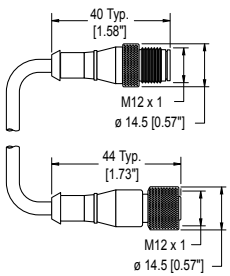
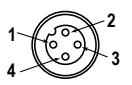
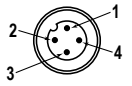
4-Pin Threaded M12 Cordsets—Double Ended				
Model	Length	Style	Dimensions	Pinout
MQDEC-401SS	0.31 m (1 ft)	Male Straight/ Female Straight		Female
MQDEC-403SS	0.91 m (2.99 ft)			
MQDEC-406SS	1.83 m (6 ft)			Male
MQDEC-412SS	3.66 m (12 ft)			
MQDEC-420SS	6.10 m (20 ft)			
MQDEC-430SS	9.14 m (30.2 ft)			
MQDEC-450SS	15.2 m (49.9 ft)			1 = Brown 2 = White 3 = Blue 4 = Black

Banner Engineering Corp Limited Warranty

Banner Engineering Corp. warrants its products to be free from defects in material and workmanship for one year following the date of shipment. Banner Engineering Corp. will repair or replace, free of charge, any product of its manufacture which, at the time it is returned to the factory, is found to have been defective during the warranty period. This warranty does not cover damage or liability for misuse, abuse, or the improper application or installation of the Banner product.

THIS LIMITED WARRANTY IS EXCLUSIVE AND IN LIEU OF ALL OTHER WARRANTIES WHETHER EXPRESS OR IMPLIED (INCLUDING, WITHOUT LIMITATION, ANY WARRANTY OF MERCHANTABILITY OR FITNESS FOR A PARTICULAR PURPOSE), AND WHETHER ARISING UNDER COURSE OF PERFORMANCE, COURSE OF DEALING OR TRADE USAGE.

This Warranty is exclusive and limited to repair or, at the discretion of Banner Engineering Corp., replacement. **IN NO EVENT SHALL BANNER ENGINEERING CORP. BE LIABLE TO BUYER OR ANY OTHER PERSON OR ENTITY FOR ANY EXTRA COSTS, EXPENSES, LOSSES, LOSS OF PROFITS, OR ANY INCIDENTAL, CONSEQUENTIAL OR SPECIAL DAMAGES RESULTING FROM ANY PRODUCT DEFECT OR FROM THE USE OR INABILITY TO USE THE PRODUCT, WHETHER ARISING IN CONTRACT OR WARRANTY, STATUTE, TORT, STRICT LIABILITY, NEGLIGENCE, OR OTHERWISE.**

Banner Engineering Corp. reserves the right to change, modify or improve the design of the product without assuming any obligations or liabilities relating to any product previously manufactured by Banner Engineering Corp. Any misuse, abuse, or improper application or installation of this product or use of the product for personal protection applications when the product is identified as not intended for such purposes will void the product warranty. Any modifications to this product without prior express approval by Banner Engineering Corp will void the product warranties. All specifications published in this document are subject to change; Banner reserves the right to modify product specifications or update documentation at any time. Specifications and product information in English supersede that which is provided in any other language. For the most recent version of any documentation, refer to: www.bannerengineering.com.

For patent information, see www.bannerengineering.com/patents.

FCC Part 15

This device complies with Part 15 of the FCC Rules. This equipment generates, uses, and can radiate radio frequency energy and, if not installed and used in accordance with the instruction manual, may cause harmful interference to radio communications. Operation is subject to the following two conditions: 1) This device may not cause harmful interference; and 2) This device must accept any interference received, including interference that may cause undesired operation.

Industry Canada

This device complies with CAN ICES-3 (B)/NMB-3(B). Operation is subject to the following two conditions: 1) This device may not cause harmful interference; and 2) This device must accept any interference received, including interference that may cause undesired operation.

Cet appareil est conforme à la norme NMB-3(B). Le fonctionnement est soumis aux deux conditions suivantes : (1) ce dispositif ne peut pas occasionner d'interférences, et (2) il doit tolérer toute interférence, y compris celles susceptibles de provoquer un fonctionnement non souhaité du dispositif.