

BS8141-0

Accessories for Sensors and Actuators – Field-Wireable Connector

Male Connector M12 × 1, Straight

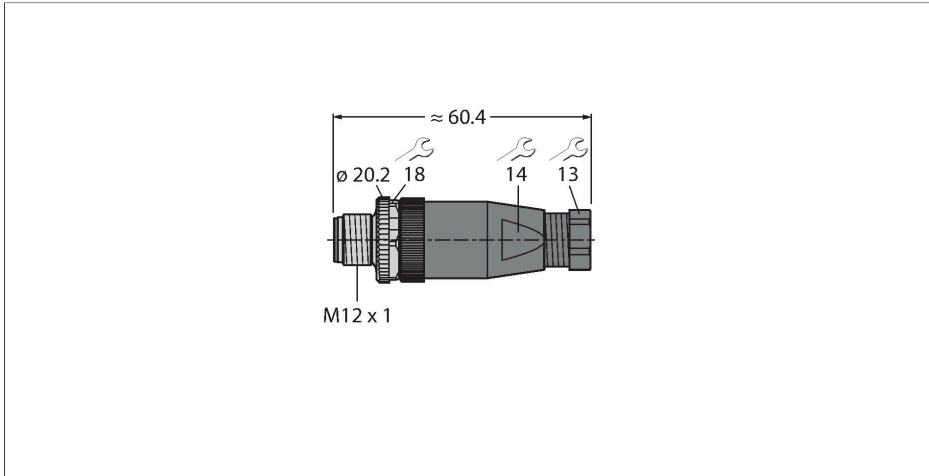

Features



- Metal coupling nut
- Protection class IP67
- UL approval
- Screw-clamp terminal
- 4-pin
- PG7 screw-in thread
- Cable feedthrough 4.0...6.0 mm

Contact assignment

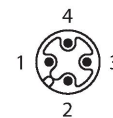

Technical data

Type	BS8141-0
ID	69010
Connector A	Male, M12 × 1, Straight, A-coded
Number of Pins	4
Contacts	CuZn, Optalloy Coating
Contact carriers	Plastic, PA, Black
Connector body	Plastic, PA, Black
Coupling nut/screw	Die-cast Zinc, GD-Zn, Nickel-plated
Seal	Plastic
Screw-in thread seal	plastic, FPM/FKM
Screw-in thread	PG7
External diameter of the cable	min. 4...6 mm
Core cross-section/Clamping ability	0.14...0.75 mm ²
Connection mode	Screw/clamp connection
Mechanical lifespan	> 100 Mating cycles
Protection class	IP67, (screwed together)
Electrical properties at +20 °C	
Rated voltage	250 V
Current	4 A
Insulation resistance	≥ 10 ⁸ Ω
forward resistance	≤ 8 mΩ
Mechanical and chemical properties	
Ambient temperature range (stationary)	-40 °C...+85 °C

Technical data

Approvals

cULus recognized
