

## Data sheet for SIMOTICS S-1FT2

Article No. : 1FT2108-4AC10-0MA0



Figure similar

Client order no. :  
Order no. :  
Offer no. :  
Remarks :

Item no. :  
Consignment no. :  
Project :

### Basic motor data

Motor type	Permanent-magnet synchronous motor, Natural cooling, IP64
Motor type	High Dynamic
Static torque	25.00 Nm
Static current	14.8 A
Maximum torque	87.00 Nm
Maximum current	77.0 A
Maximum speed	5,600 rpm
Rotor moment of inertia	22.3000 kgcm <sup>2</sup>
Weight	19.7 kg

### Rated data

SINAMICS S210, 3AC 400V

Rated speed	2,000 rpm
Rated torque	30.00 Nm
Rated current	12.8 A
Rated power	6.30 kW

### Encoder system

Encoder system	Encoder AM22DQC: Absolute encoder 22 bit + 12 bit multitrurn
----------------	--

### Motor connection

Connection type	OCC for S210
Connector size	M23

### Mechanical data

Design acc. to Code I	IM B5 (IM V1, IM V3)
Vibration severity grade	Grade A
Shaft height	80
Flange size (AB)	155 mm
Centering ring (N)	130 mm
Hole circle (M)	165 mm
Screw-on hole (S)	11.0 mm
Overall length (LB)	280 mm
Diameter of shaft (D)	32 mm
Length of shaft (E)	58 mm
Length of flange diagonal (P)	194 mm
Shaft end	Plain shaft
Color of the housing	Standard (Anthracite, similar to RAL 7016)

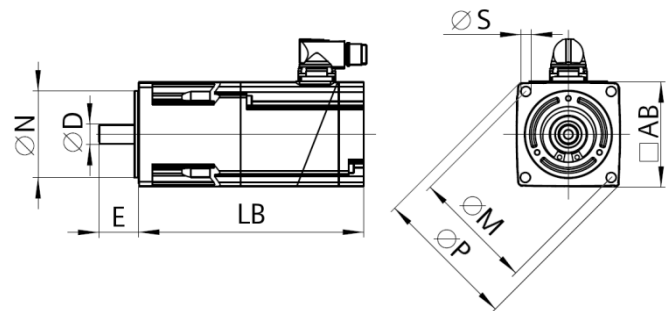

### Holding brake

Holding torque	36.00 Nm
Average dynamic torque	15.00 Nm
Opening time	120 ms
Closing time	40 ms
Maximum single switching energy <sup>1)</sup>	1,300 J
Service life, operating energy	2,400,000 J
Holding current <sup>2)</sup>	0.5 A
Break-induced current for 500 ms <sup>2)</sup>	1.4 A

<sup>1)</sup> Up to three consecutive emergency stops and up to 25% of all emergency stops as a Wmax high energy stop possible.

<sup>2)</sup> Typical value for 20°C ambient temperature. At -15°C the break-induced currents can be increased by up to 30%.