

PTCB E1 48DC/2A NO - Electronic circuit breaker



1471918

<https://www.phoenixcontact.com/gb/products/1471918>

Please be informed that the data shown in this PDF document is generated from our online catalog. Please find the complete data in the user documentation. Our general terms of use for downloads are valid.

Single-channel, electronic device protection for 48 V DC loads. Fixed nominal current of 2 A. With floating remote indication contact. Can be combined with CLIPLINE terminal blocks. For installation on DIN rails.



Your advantages

- Simple application setup due to bridging option to CLIPLINE complete terminal block system
- More space in the control cabinet: narrowest protection on just 6 mm width
- Flexible use and reduction of inventory due to adjustable amp values on each device for wide range of applications

Commercial data

Item number	1471918
Packing unit	1 pc
Minimum order quantity	1 pc
Sales key	CLA135
Product key	CLA135
GTIN	4063151881146
Weight per piece (including packing)	33.66 g
Weight per piece (excluding packing)	27.24 g
Customs tariff number	85363010
Country of origin	DE

Technical data

Notes

General

Note	Repeated hard short circuits can reduce the melting integral of the integrated backup fuse.
	This device is not a switching device acc. to UL508

Product properties

Product type	Device circuit breakers
Product family	PTCB
Type	DIN rail module, one-piece
Number of positions	1

Insulation characteristics

Protection class	III
Pollution degree	2

Electrical properties

General

Operating voltage	30 V DC ... 56 V DC
Rated voltage	48 V DC
Rated current I_N	20 A DC (Total current input) 2 A DC (Rated current output)
Rated current (pre-adjusted)	2 A
Rated surge voltage	0.5 kV
Tripping method	E (electronic)
Feedback resistance	max. 60 V DC
Required backup fuse	Only required if I_{max} of the power supply > the short-circuit switching capacity. Integrated failsafe element.
Short-circuit switching capacity	300 A
Dielectric strength	max. 60 V DC (Load circuit)
Fuse	electronic
Efficiency	> 99 %
Closed circuit current I_0	typ. 10 mA
Power dissipation	typ. 0.5 W (No-load operation) < 0.8 W (Nominal operation)
Module initialization time	< 350 ms
Waiting time after switch off of a channel	5 s (at overload / short circuit)
Measuring tolerance I	± 15 %
MTBF (IEC 61709, SN 29500)	21687269 h (at 25 °C with 21 % load) 8362602 h (at 40 °C with 34.25% load) 1281969 h (at 60 °C with 100% load)

PTCB E1 48DC/2A NO - Electronic circuit breaker



1471918

<https://www.phoenixcontact.com/gb/products/1471918>

Voltage drop	0.1 V (at 2 A)
Fail-safe element	5 A DC
Contact switching type	without electrical isolation

Load circuit

Shutdown time	≤ 10 ms (For short circuit > 3.0 x I _N)
	≤ 50 ms (with overload >2.0 x I _N)
	≤ 1 s (with overload 1.5...2.0 x I _N)
	≤ 4 s (with overload 1.1...1.5 x I _N)
Undervoltage switch-off	≤ 28.5 V DC (active)
	≥ 29.5 V DC (inactive)
Overvoltage switch-off	≥ 56.5 V DC (active)
	≤ 55.5 V DC (inactive)
Max. capacitive load	10000 µF (Depending on the current setting and the available short-circuit current, e.g., 3 mF at 48 V DC and 0.1 ohm cable)

Indicator/remote signaling

Connection name	Remote indication circuit
Switching function	N/O contact
Operating voltage	0 V DC ... 56 V DC
Operating current	100 mA DC

Connection data

Main circuit IN+

Connection method	Push-in connection
Stripping length	8 mm
Conductor cross-section flexible	0.2 mm ² ... 2.5 mm ²
Conductor cross-section rigid	0.2 mm ² ... 4 mm ²
Conductor cross-section AWG	24 ... 12
Conductor cross-section, flexible, with ferrule, with plastic sleeve	0.2 mm ² ... 2.5 mm ²
Conductor cross-section flexible, with ferrule without plastic sleeve	0.2 mm ² ... 2.5 mm ²

Main circuit IN-

Connection method	Push-in connection
Stripping length	8 mm
Conductor cross-section flexible	0.2 mm ² ... 2.5 mm ²
Conductor cross-section rigid	0.2 mm ² ... 4 mm ²
Conductor cross-section AWG	24 ... 12
Conductor cross-section, flexible, with ferrule, with plastic sleeve	0.2 mm ² ... 2.5 mm ²
Conductor cross-section flexible, with ferrule without plastic sleeve	0.2 mm ² ... 2.5 mm ²

Main circuit OUT

Connection method	Push-in connection
Stripping length	8 mm

PTCB E1 48DC/2A NO - Electronic circuit breaker



1471918

<https://www.phoenixcontact.com/gb/products/1471918>

Conductor cross-section flexible	0.2 mm ² ... 2.5 mm ²
Conductor cross-section rigid	0.2 mm ² ... 4 mm ²
Conductor cross-section AWG	24 ... 12
Conductor cross-section, flexible, with ferrule, with plastic sleeve	0.2 mm ² ... 2.5 mm ²
Conductor cross-section flexible, with ferrule without plastic sleeve	0.2 mm ² ... 2.5 mm ²

Remote indication circuit

Connection method	Push-in connection
Stripping length	8 mm
Conductor cross-section flexible	0.2 mm ² ... 2.5 mm ²
Conductor cross-section rigid	0.2 mm ² ... 4 mm ²
Conductor cross-section AWG	24 ... 14
Conductor cross-section, flexible, with ferrule, with plastic sleeve	0.2 mm ² ... 2.5 mm ²
Conductor cross-section flexible, with ferrule without plastic sleeve	0.2 mm ² ... 2.5 mm ²

Signaling

Channel LED off	off (Channel switched off)
Channel LED yellow	lit (Channel switched on, channel load > 80%)
Channel LED green	lit (Channel switched on)
Channel LED red	lit (Channel switched off, over- or undervoltage active)
	ON temporarily (Channel switched off, 5 s cool-down phase, overload or short-circuit release)
	flashing (Channel switched off, ready to be switched back on, overload or short-circuit release)
	flashing quickly (Channel switched off, external voltage at the output, possible installation error)
Channel LED red-yellow	flashing (Overtemperature or P _{OUT} greater than 100 W)

Dimensions

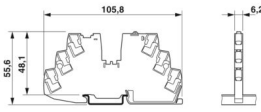
Dimensional drawing	
Width	6.2 mm
Height	105.8 mm
Depth	55.6 mm (incl. DIN rail 7.5 mm)

Material specifications

Color	gray (RAL 7042)
Material	PBT
	PBT
Flammability rating according to UL 94	V-0

Environmental and real-life conditions

PTCB E1 48DC/2A NO - Electronic circuit breaker



1471918

<https://www.phoenixcontact.com/gb/products/1471918>

Ambient conditions

Degree of protection	IP20
Ambient temperature (operation)	-30 °C ... 60 °C
Ambient temperature (storage/transport)	-40 °C ... 70 °C
Altitude	≤ 3000 m up to 52 °C (amsl)
	≤ 4000 m up to 46 °C (amsl)
Humidity test	96 h, 95 % RH, 40 °C
Shock (operation)	30g (IEC 60068-2-27, Test Ea)
Vibration (operation)	10 Hz ... 59.6 Hz (Amplitude ±0.35 mm; in accordance with IEC 60068-2-6, Test Fc)
	59.6 Hz ... 150 Hz (Acceleration 5g; in accordance with IEC 60068-2-6, Test Fc)
	5 Hz ... 100 Hz (Resonance search 4g; resonance frequency 4g; 90 min in accordance with DNV GL Class B)

Approvals

UL approval

Identification	UL/C-UL Listed UL 508
	UL Recognized UL 2367

Standards and regulations

Standards/specifications	EN 61000-6-2
Note	EMC – Immunity for industrial areas
Standards/specifications	EN 61000-6-3
Note	EMC – Emission for residential, business and commercial properties and small operations
Standards/specifications	EN 60068-2-78
Note	Environmental influences – Moisture and heat, constant
Standards/specifications	EN 50178
Note	Equipping power installations with electronic equipment
Standards/specifications	EN 60068-2-6
Note	Environmental influences – Vibrations (sinusoidal)
Standards/specifications	EN 60068-2-27
Note	Environmental influences – Shocks
Standards/specifications	EN 60068-2-30
Note	Environmental influences – Part 2–30: Tests – Test Db: Damp heat, cyclical

Mounting

Mounting type	DIN rail: 35 mm
---------------	-----------------

PTCB E1 48DC/2A NO - Electronic circuit breaker



1471918

<https://www.phoenixcontact.com/gb/products/1471918>

Drawings

Dimensional drawing

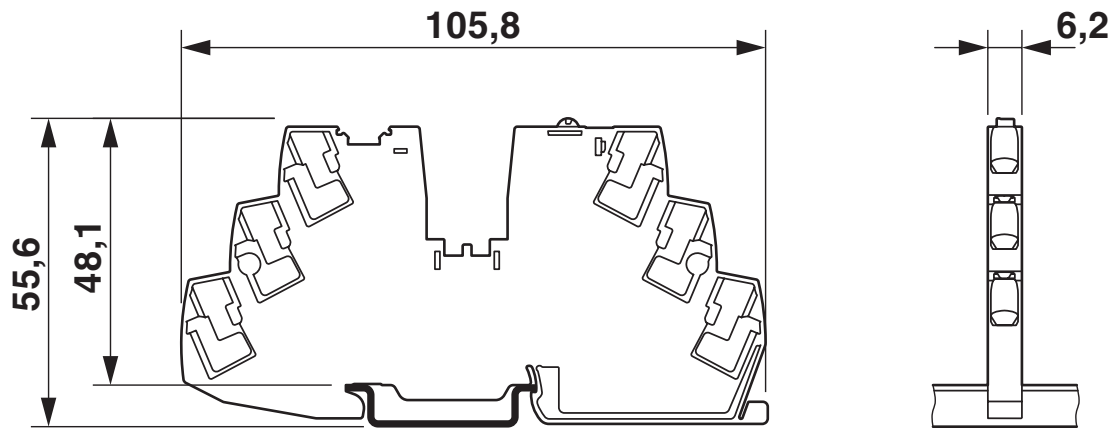

Diagram

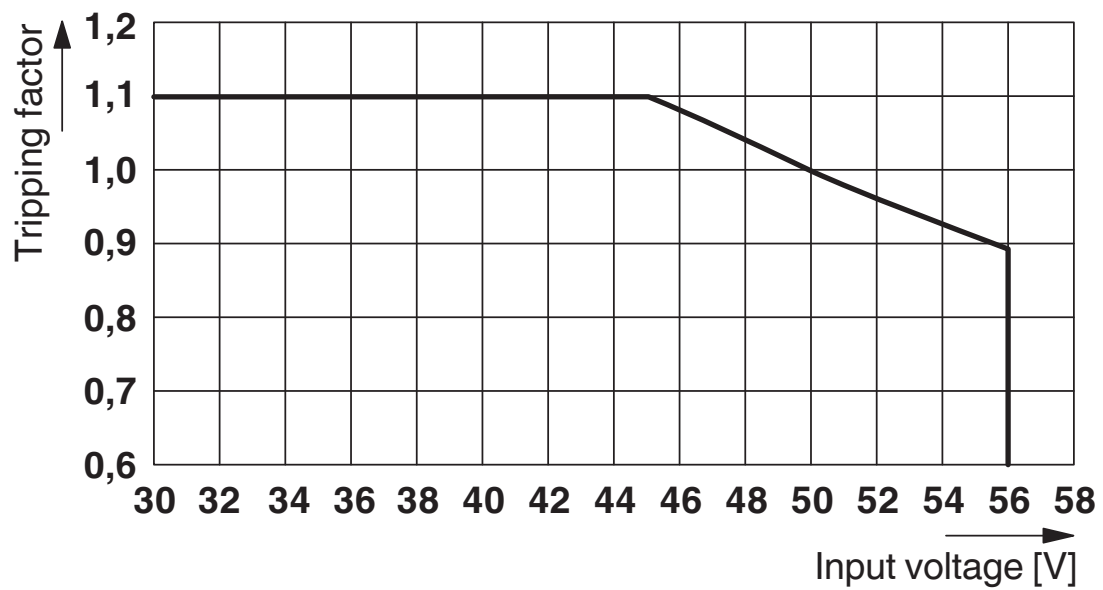

Diagram

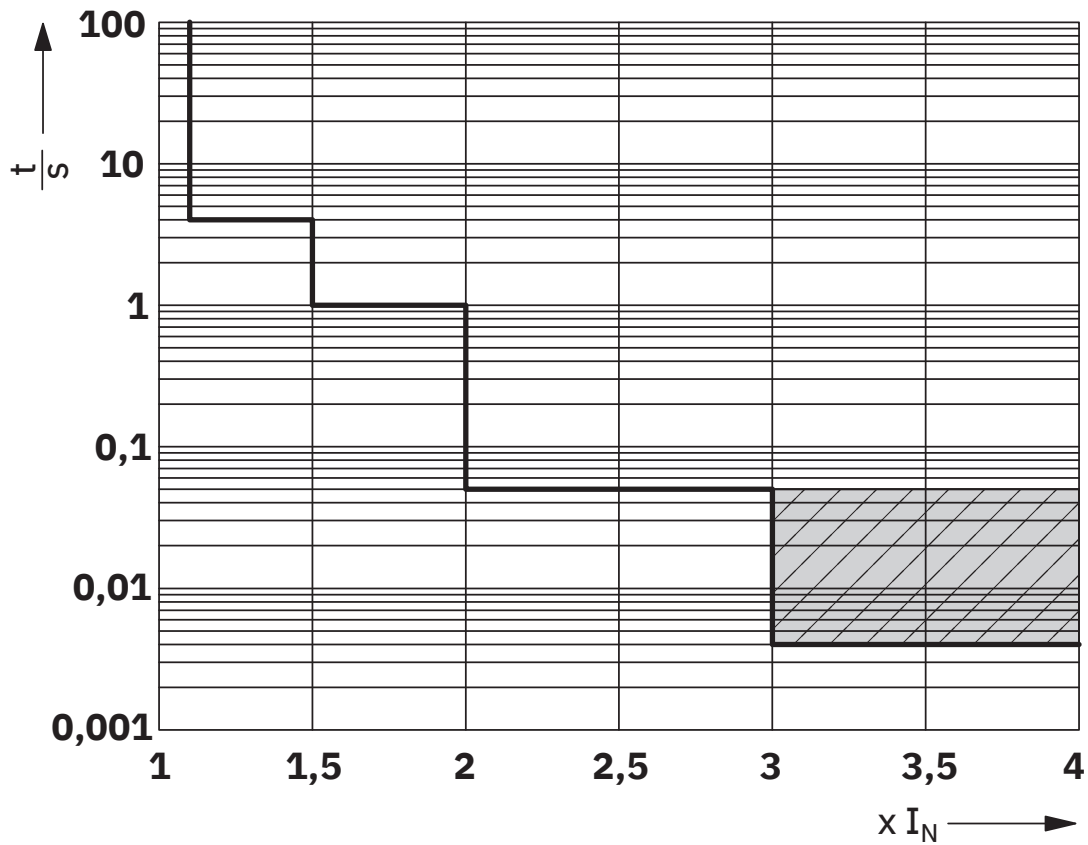

Trigger characteristic in the DC range

Block diagram

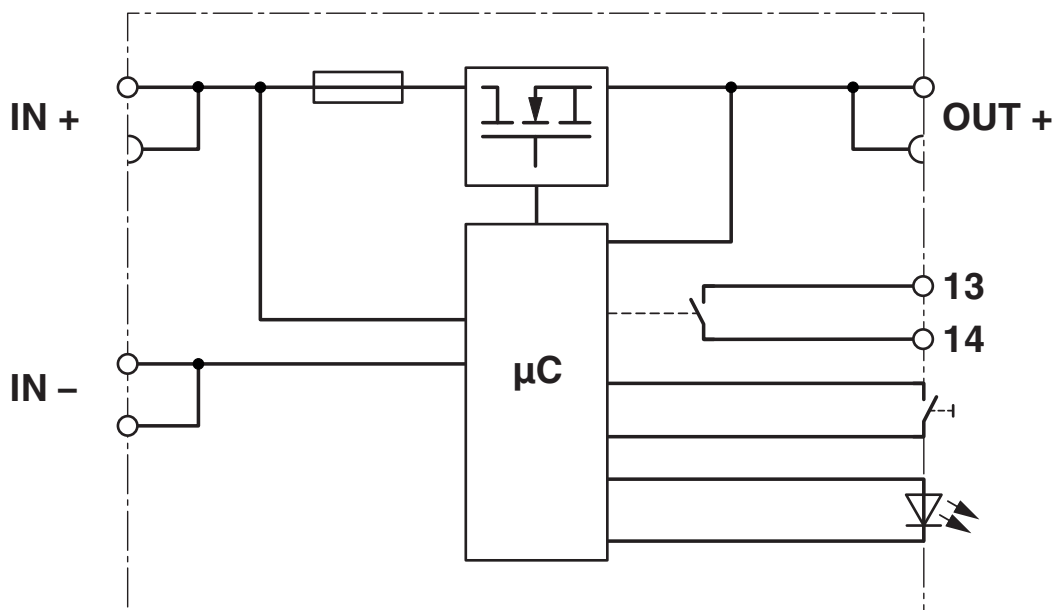

PTCB E1 48DC/2A NO - Electronic circuit breaker





1471918

<https://www.phoenixcontact.com/gb/products/1471918>

Approvals

To download certificates, visit the product detail page: <https://www.phoenixcontact.com/gb/products/1471918>

 **UL Listed**
Approval ID: E123528

 **cUL Listed**
Approval ID: E123528

 **UL Recognized**
Approval ID: E317172

PTCB E1 48DC/2A NO - Electronic circuit breaker



1471918

<https://www.phoenixcontact.com/gb/products/1471918>

Classifications

ECLASS

ECLASS-13.0	27140401
ECLASS-15.0	27140401

ETIM

ETIM 9.0	EC003538
----------	----------

1471918

<https://www.phoenixcontact.com/gb/products/1471918>

Environmental product compliance

EU RoHS

Fulfills EU RoHS substance requirements	Yes
Exemption	7(a), 7(c)-I

China RoHS

Environment friendly use period (EFUP)	EFUP-50
	An article-related China RoHS declaration table can be found in the download area for the respective article under "Manufacturer declaration". For all articles with EFUP-E, no China RoHS declaration table issued and required.

EU REACH SVHC

REACH candidate substance (CAS No.)	Lead(CAS: 7439-92-1)
-------------------------------------	----------------------

Phoenix Contact 2025 © - all rights reserved
<https://www.phoenixcontact.com>

PHOENIX CONTACT Ltd
Halesfield 13, Telford
Shropshire, TF7 4PG
01952 681700
info@phoenixcontact.co.uk