

Overview

- High quality torsionally stiff and backlash free coupling
- Compensating of mounting errors
- Balanced torsional rigidity (torsional spring constant)
- Protection against shaft currents with an insulated hub on non-drive end
- Form-fit connection thanks to keyway



Technical data

Technical data

Shaft diameter D1	11 mm
Shaft diameter D2	16 mm
Keyway D1	4 mm
Keyway D2	5 mm
Operating speed	≤13000 rpm (highspeed)
Moment of inertia	$258 \cdot 10^{-3} \text{ kgcm}^2$
Torsional rigidity	1400 Nm/rad
Operating torque	≤8 Nm

Technical data

Maximum torque	10 Nm
Admissible axial movement	± 0.7 mm (±0,3 mm at version with insulated hub version)
Admissible parallel misalignment	± 0.15 mm (±0,05 mm at version with insulated hub version)
Admissible angular error	± 1 °
Electrical insulation	Yes
Weight approx.	95 g
Material	Spring disks: X12 CrNi 17 7

Description

Spring disk coupling, which combines the necessary torsional stiffness with the ability to compensate for axial displacement which occurs especially through heat expansion of the drive and the play backlash of the ball bearings.

Dimensions

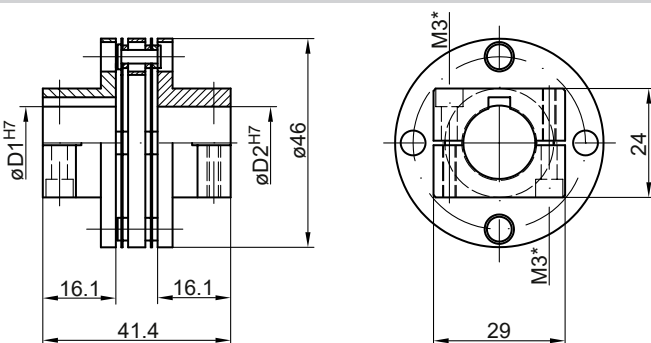

* Maximum tightening torque:
Mt = 1 Nm (plastic side)
Mt = 1.3 ± 10 % Nm (metal side)

Assembly drawing

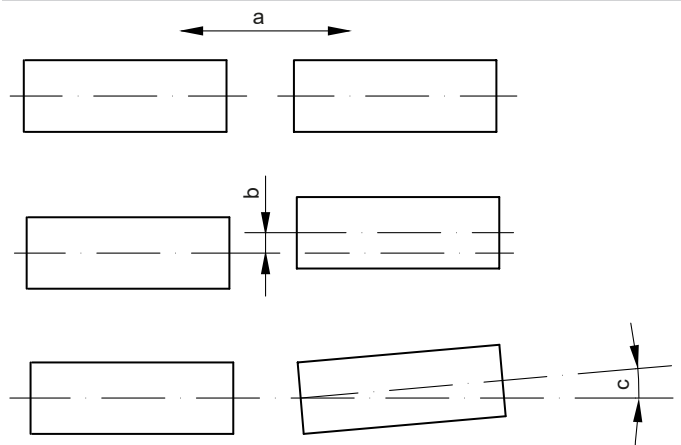

a = Admissible axial movement
b = Admissible parallel misalignment
c = Admissible angular error