



# HART Loop Converter

## KFD2-HLC-Ex1.D

- 1-channel isolated barrier
- 24 V DC supply (Power Rail)
- HART field device input with transmitter power supply
- Usable as signal splitter (1 input and several outputs)
- 3 analog outputs 4 mA ... 20 mA
- Sink and source mode output
- Configurable by keypad



### Function

This isolated barrier is used for intrinsic safety applications. It is a HART loop converter that provides power to transmitters or can be connected to existing HART loops in parallel. It is able to evaluate up to four HART variables (PV, SV, TV, QV). Of those four HART variables, the data contained in any three of them can be converted to three different 4 mA ... 20 mA current signals. These loop signals can be connected to display devices or analog inputs on the process control system/ control system. The unit is easily programmed by the use of a keypad located on the front of the unit or with the PACTware™ configuration software. For additional information, refer to the manual and [www.pepperl-fuchs.com](http://www.pepperl-fuchs.com).

### Application

- Configurable as primary module or secondary module
- Automatic HART burst supported
- Support for a HART handheld device connected on safe area side
- Can be configured to assign the same input variable to multiple outputs (signal splitting)

### Wiring Diagram

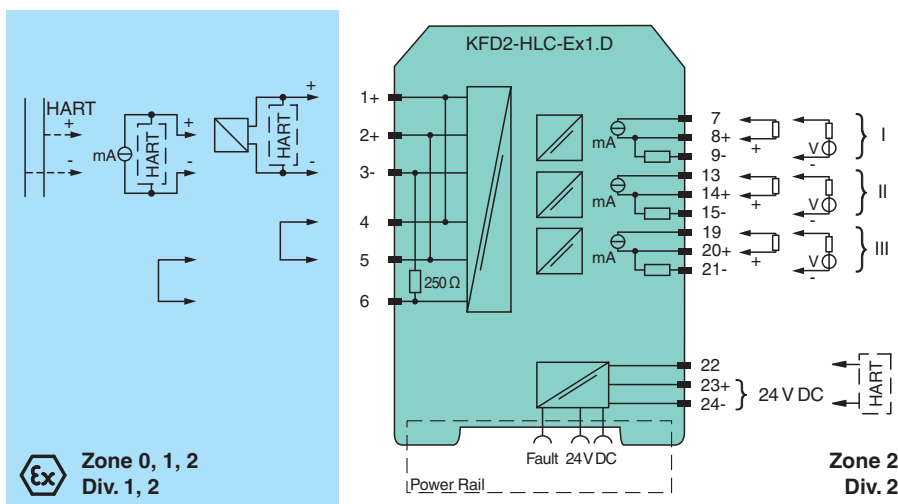

### Technical Data

General specifications	
Signal type	Analog input
<b>Supply</b>	
Connection	Power Rail or terminals 23+, 24-
Rated voltage	U <sub>r</sub> 19 ... 30 V DC

Release date: 2025-10-13 Date of issue: 2025-10-13 Filename: 261916\_eng.pdf

Refer to "General Notes Relating to Pepperl+Fuchs Product Information".

Pepperl+Fuchs Group  
www.pepperl-fuchs.com

USA: +1 330 486 0002  
pa-info@us.pepperl-fuchs.com

Germany: +49 621 776 2222  
pa-info@de.pepperl-fuchs.com

Singapore: +65 6779 9091  
pa-info@sg.pepperl-fuchs.com



## Technical Data

Rated current	$I_r$	approx. 120 mA at 24 V DC
Power dissipation		2.3 W
Power consumption		2.9 W
<b>HART signal channels (intrinsically safe)</b>		
Conformity		HART field device input (revision 5 to 7)
<b>Interface</b>		
Programming interface		programming socket
<b>Input</b>		
Connection side		field side
Connection		terminals 1, 2, 3, 4, 5, 6
Open circuit voltage/short-circuit current		typ. 24 V / 28 mA
Input resistance		250 $\Omega$ , 5 % (terminals 2, 3 and with jumper on 5, 6)
Available voltage		$\geq 15.5$ V at 20 mA, short-circuit protected
<b>Output</b>		
Connection side		control side
Connection		output I: terminals 7, 8, 9 , output II: terminals 13, 14, 15 , output III: terminals 19, 20, 21
Output signal		analog
Voltage range		5 ... 30 V , sink mode from external supply
Current range		4 ... 20 mA , (source or sink mode)
Load		max. 650 $\Omega$ , source mode
Fault signal		downscale $I \leq 2$ mA, upscale $I \geq 21.5$ mA (acc. NAMUR NE43) or hold measurement value
Other outputs		HART communicator on terminals 22, 24
Collective error message		Power Rail and LED red
<b>Transfer characteristics</b>		
Output I, II, III		
Resolution		max. 2 $\mu$ A
Accuracy		$< 20$ $\mu$ A, 10 $\mu$ A typ.
Influence of ambient temperature		$< \pm 2$ $\mu$ A/K
Duration of measurement/Response delay		HART message acquisition time plus 100 ms
<b>Galvanic isolation</b>		
Output I/II/III/power supply		functional insulation acc. to IEC 62103, rated insulation voltage 50 V <sub>eff</sub>
<b>Indicators/settings</b>		
Display elements		LEDs , display
Control elements		Control panel
Configuration		via operating buttons via PACTware
Labeling		space for labeling at the front
<b>Directive conformity</b>		
Electromagnetic compatibility		
Directive 2014/30/EU		EN 61326-1:2013 (industrial locations)
Low voltage		
Directive 2014/35/EU		EN 61010-1:2010
<b>Conformity</b>		
Electromagnetic compatibility		NE 21:2006
Degree of protection		IEC 60529:2001
<b>Ambient conditions</b>		
Ambient temperature		-20 ... 60 °C (-4 ... 140 °F)
<b>Mechanical specifications</b>		
Degree of protection		IP20
Connection		screw terminals
Mass		300 g
Dimensions		40 x 119 x 115 mm (1.6 x 4.7 x 4.5 inch) (W x H x D) , housing type C2

Release date: 2025-10-13 Date of issue: 2025-10-13 Filename: 261916\_eng.pdf

## Technical Data

Mounting		on 35 mm DIN mounting rail acc. to EN 60715:2001
<b>Data for application in connection with hazardous areas</b>		
EU-type examination certificate		BASEEFA 07 ATEX 0174
Marking		Ⓔ II (1)G [Ex ia Ga] IIC Ⓔ II (1)D [Ex ia Da] IIIC
<b>Supply</b>		
Maximum safe voltage	$U_m$	253 V AC (Attention! The rated voltage can be lower.)
Equipment		terminals 1, 4/3 (with link between terminals 4 and 5)
Voltage	$U_o$	25.2 V
Current	$I_o$	104.9 mA
Power	$P_o$	0.661 W
Internal capacitance	$C_i$	1.1 nF
Internal inductance	$L_i$	0 mH
<b>Equipment</b>		
		terminals 2, 5/3
Voltage	$U_i$	< 28 V
Power	$P_i$	< 1.33 W
Voltage	$U_o$	1.1 V
Current	$I_o$	11.9 mA
Power	$P_o$	4 mW
Internal capacitance	$C_i$	0 $\mu$ F
Internal inductance	$L_i$	0 mH
<b>Output I, II, III</b>		
		terminals 7, 8, 9; 13, 14, 15; 19, 20, 21 non-intrinsically safe
Maximum safe voltage	$U_m$	253 V (Attention! $U_m$ is no rated voltage.)
<b>Certificate</b>		
		PF 07 CERT 1142 X
<b>Marking</b>		
		Ⓔ II 3G Ex nA IIC T4 Gc
<b>Galvanic isolation</b>		
Input/Other circuits		safe electrical isolation acc. to IEC/EN 60079-11, voltage peak value 375 V
<b>Directive conformity</b>		
Directive 2014/34/EU		EN IEC 60079-0:2018+AC:2020, EN 60079-11:2012, EN 60079-15:2010
<b>International approvals</b>		
<b>FM approval</b>		
Control drawing		116-0129
<b>IECEx approval</b>		
IECEx certificate		IECEx BAS 07.0047
IECEx marking		[Ex ia Ga] IIC, [Ex ia Da] IIIC
<b>General information</b>		
Supplementary information		Observe the certificates, declarations of conformity, instruction manuals, and manuals where applicable. For information see <a href="http://www.pepperl-fuchs.com">www.pepperl-fuchs.com</a> .

Release date: 2025-10-13 Date of issue: 2025-10-13 Filename: 261916\_eng.pdf

Refer to "General Notes Relating to Pepperl+Fuchs Product Information".

Pepperl+Fuchs Group  
www.pepperl-fuchs.com

USA: +1 330 486 0002  
pa-info@us.pepperl-fuchs.com

Germany: +49 621 776 2222  
pa-info@de.pepperl-fuchs.com

Singapore: +65 6779 9091  
pa-info@sg.pepperl-fuchs.com

 PEPPERL+FUCHS

**Assembly**

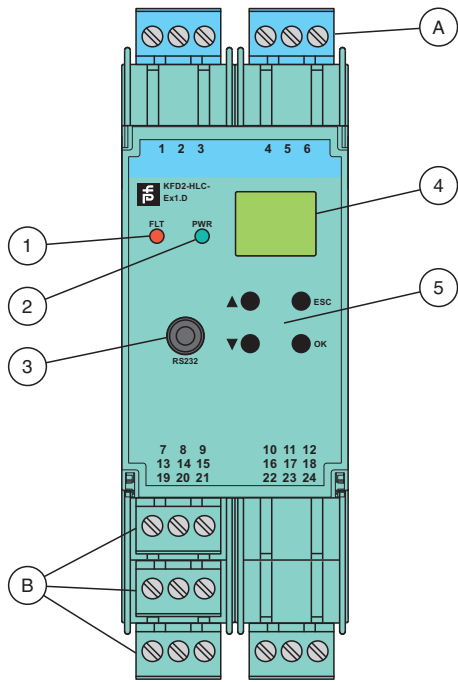

1	LED red: Fault signal
2	LED green: Power supply
3	Programming socket
4	LCD display
5	Keypad
A	Removable terminals, blue
B	Removable terminals, green

Release date: 2025-10-13 Date of issue: 2025-10-13 Filename: 261916\_eng.pdf