

# PLC-RSC-120UC/21/EX - Relay module



2909525

<https://www.phoenixcontact.com/gb/products/2909525>

Please be informed that the data shown in this PDF document is generated from our online catalog. Please find the complete data in the user documentation. Our general terms of use for downloads are valid.



PLC-INTERFACE, consisting of DIN-rail-mountable basic terminal block in 6.2 mm with screw connection and plug-in miniature relay with 6 A power contact, 1 changeover contact, 120 V AC/110 V DC input voltage. Approved according to ATEX/IECEx (Zone 2) and Ex Zone Class I, Div. 2.

## Commercial data

Item number	2909525
Packing unit	10 pc
Minimum order quantity	10 pc
Sales key	DK622K
Product key	DK622K
GTIN	4055626363622
Weight per piece (including packing)	42.71 g
Weight per piece (excluding packing)	36.8 g
Customs tariff number	85364900
Country of origin	DE

## Technical data

### Notes

#### Utilization restriction

EMC note	EMC: class A product, see manufacturer's declaration in the download area
----------	---

### Product properties

Product type	Relay Module
Product family	PLC-INTERFACE
Application	Class I, Division 2 potentially explosive areas
Operating mode	100% operating factor
Mechanical service life	2x 10 <sup>7</sup> cycles

#### Insulation characteristics: Standards/regulations

Overtoltage category	III
Pollution degree	3

#### Data management status

Date of last data management	22.09.2025
------------------------------	------------

### Electrical properties

Maximum power dissipation for nominal condition	0.42 W
Test voltage (Winding/contact)	4 kV AC (50 Hz, 1 min., winding/contact)

### Input data

#### Coil side

Nominal input voltage $U_N$	120 V AC
	110 V DC
Input voltage range	93.6 V AC ... 168 V AC (20 °C)
	85.8 V DC ... 154 V DC (20 °C)
Nominal voltage (plugged-in electromechanical relay)	60 V DC
Drive and function	monostable
Drive (polarity)	polarized
Typical input current at $U_N$	3.5 mA ( $U_N = 120$ V AC)
	3 mA ( $U_N = 110$ V DC)
Typical response time	6 ms
Typical release time	15 ms
Protective circuit	Bridge rectifier; Bridge rectifier
Operating voltage display	Yellow LED

### Output data

# PLC-RSC-120UC/21/EX - Relay module



2909525

<https://www.phoenixcontact.com/gb/products/2909525>

## Switching

Contact switching type	1 changeover contact
Type of switch contact	Single contact
Contact connection type	Power contact
Contact material	AgSnO
Maximum switching voltage	250 V AC/DC (The separating plate PLC-ATP should be installed for voltages larger than 250 V (L1, L2, L3) between identical terminal blocks in adjacent modules. Potential bridging is then carried out with FBST 8-PLC... or ...FBST 500...)
Minimum switching voltage	5 V AC/DC (100 mA)
Limiting continuous current	6 A (Derating)
Maximum inrush current	10 A (4 s)
Min. switching current	10 mA (12 V)
Interrupting rating (ohmic load) max.	140 W (24 V DC) 20 W (48 V DC) 18 W (60 V DC) 23 W (110 V DC) 40 W (220 V DC) 1500 VA (250 V AC)
Switching capacity	2 A (24 V (DC13)) 0.2 A (110 V (DC13)) 0.1 A (220 V (DC13)) 3 A (24 V (AC15)) 3 A (120 V (AC15)) 3 A (230 V (AC15))

## Connection data

Connection method	Screw connection
Stripping length	8 mm
Screw thread	M3
Conductor cross-section rigid	0.14 mm <sup>2</sup> ... 2.5 mm <sup>2</sup>
Conductor cross-section flexible	0.14 mm <sup>2</sup> ... 2.5 mm <sup>2</sup> 0.2 mm <sup>2</sup> ... 2.5 mm <sup>2</sup> (Single ferrule) 2x 0.5 mm <sup>2</sup> ... 1.5 mm <sup>2</sup> (TWIN ferrule)
Conductor cross-section AWG	26 ... 14
Tightening torque	0.6 Nm ... 0.8 Nm

## Dimensions

Width	6.2 mm
Height	80 mm
Depth	94 mm

## Material specifications

Color	gray (RAL 7042)
Flammability rating according to UL 94 (Housing)	V0 (Housing)

## Environmental and real-life conditions

### Ambient conditions

Degree of protection (Relay)	RT III (Relay)
Degree of protection (Relay base)	IP20 (Relay base)
Ambient temperature (operation)	-40 °C ... 60 °C
Ambient temperature (storage/transport)	-40 °C ... 85 °C
Altitude	≤ 2000 m

## Approvals

### CE

Certificate	CE-compliant
-------------	--------------

### ATEX

Identification	⊕ II 3G Ex ec nC IIC T4 Gc
Certificate	IBExU16ATEXB015 X

### IECEX

Identification	Ex ec nC IIC T4 Gc
Certificate	IECEX IBE 16.0029X

### UKCA Ex (UKEX)

Identification	⊕ II 3 G Ex ec nC IIC T4 Gc
Certificate	PxCIF21UKEX2909514X

### CCC / China-Ex

Identification	Ex ec nC IIC T4 Gc
Certificate	2021122304114118

### UL, USA/Canada

Identification	Class I, Zone 2, AEx ec nC IIC T4
	Class I, Zone 2, Ex ec nC IIC Gc T4 X

### Shipbuilding approval

Certificate	TAE0000196
-------------	------------

### Corrosive gas test

Identification	ISA-S71.04. G3 Harsh Group
	EN 60068-2-60

### Shipbuilding data

Temperature	D
Humidity	A
Vibration	B/C
EMC	B
Enclosure	Required protection according to the Rules shall be provided upon installation on board

# PLC-RSC-120UC/21/EX - Relay module



2909525

<https://www.phoenixcontact.com/gb/products/2909525>

## EMC data

Electromagnetic compatibility	Conformance with EMC directive
Low Voltage Directive	Conformance with Low Voltage Directive

## Standards and regulations

### Standards/regulations

Standards/regulations	IEC 60664
	IEC 60947-5-1
	IEC/EN 60079-0
	IEC/EN 60079-7
	IEC/EN 60079-15

### GB Standard

Standards/regulations	GB/T 3836.1
	GB/T 3836.3
	GB/T 3836.8

## Mounting

Mounting type	DIN rail mounting
Assembly note	in rows with zero spacing
Mounting position	any

Drawings

Diagram

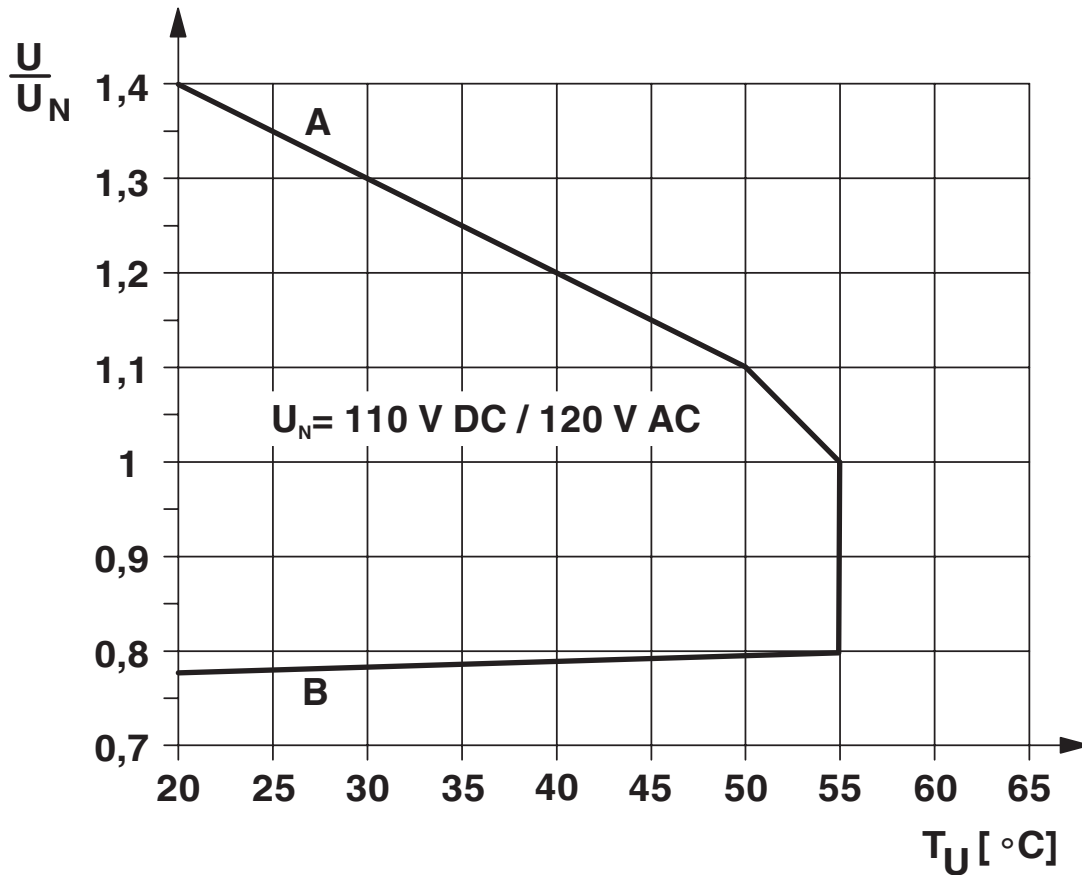

Curve A

Maximum permissible continuous voltage  $U_{\text{max}}$  with limiting continuous current on the contact side (see relevant technical data)

Curve B

Minimum permissible operate voltage  $U_{\text{op}}$  after pre-excitation (see relevant technical data)



Interrupting rating



Permissible humidity for operation and storage.

The maximum permissible ambient temperature as specified in the data sheet must be observed.

Area A: Ice buildup at ambient temperatures  $\leq 0^\circ\text{C}$  must be prevented

Area B: Condensation at ambient temperatures  $> 0^\circ\text{C}$  must be prevented

On 30 full days that are naturally distributed across an entire year, a humidity level of 95% is permissible at an ambient temperature  $\leq 25^\circ\text{C}$ .

# PLC-RSC-120UC/21/EX - Relay module

2909525

<https://www.phoenixcontact.com/gb/products/2909525>

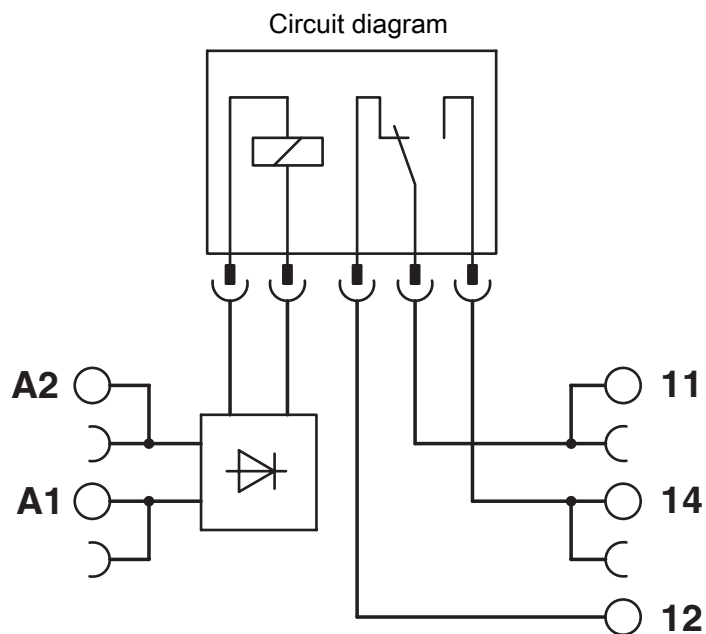

# PLC-RSC-120UC/21/EX - Relay module



2909525

<https://www.phoenixcontact.com/gb/products/2909525>

## Approvals

To download certificates, visit the product detail page: <https://www.phoenixcontact.com/gb/products/2909525>



**DNV GL**

Approval ID: TAE0000196



**cULus Listed**

Approval ID: E140324



**EAC Ex**

Approval ID: RU C-DE.AB72.B.02328



**IECEx**

Approval ID: IECEx IBE 16.0029X



**ATEX**

Approval ID: 16ATEXB015X



**cULus Listed**

Approval ID: E199827



**CCC**

Approval ID: 2021122304114118

# PLC-RSC-120UC/21/EX - Relay module



2909525

<https://www.phoenixcontact.com/gb/products/2909525>

## Classifications

### ECLASS

ECLASS-13.0	27371601
ECLASS-15.0	27371601

### ETIM

ETIM 9.0	EC001437
----------	----------

### UNSPSC

UNSPSC 21.0	39122300
-------------	----------

## Environmental product compliance

### EU RoHS

Fulfills EU RoHS substance requirements	Yes
Exemption	7(a), 7(c)-I

### China RoHS

Environment friendly use period (EFUP)	EFUP-50
	An article-related China RoHS declaration table can be found in the download area for the respective article under "Manufacturer declaration". For all articles with EFUP-E, no China RoHS declaration table issued and required.

### EU REACH SVHC

REACH candidate substance (CAS No.)	Hexahydromethylphthalic anhydride(CAS: n/a)
	Lead(CAS: 7439-92-1)
	2,2',6,6'-tetrabromo-4,4'-isopropylidenediphenol(CAS: 79-94-7)
SCIP	0aa60854-16a3-42a1-a031-d804137e9f33