

## EIL580P-BT12.5FF.01024.B

With blind hollow shaft, 1...65536 pulses per revolution programmable (interpolated system)

Article number: 11121825

### Overview

- Size ø58 mm
- Precise optical sensing (interpolated)
- Output signal level programmable (TTL or HTL)
- Blind hollow shaft, ø12 mm
- Flange connector M23, 12-pin CCW, radial
- Pulses per revolution 1...65536, programmable
- High protection IP 65
- High resistance to shock and vibrations



### Technical data

#### Technical data - electrical ratings

Voltage supply	4.75...30 VDC
Reverse polarity protection	Yes
Short-circuit proof	Yes
Consumption w/o load	≤70 mA
Initializing time	≤ 30 ms after power on
Pulses per revolution	1024
Duty cycle	45...55 % typical at 1024, 2048 ppr (further see table Duty cycle)
Reference signal	Zero pulse, width 90° ±10 %
Sensing method	Optical
Output frequency	≤300 kHz (TTL)
Output signals	A+, B+, R+, A-, B-, R-
Output stages	TTL/RS422
Programmable parameters	Output level TTL/HTL Pulse number 1...65536 Zero pulse width 90°/180° Zero pulse position Signal sequence
Interference immunity	EN 61000-6-2

#### Technical data - electrical ratings

Emitted interference	EN 61000-6-3
Approval	UL 508 / CSA 22.2
<b>Technical data - mechanical design</b>	
Size (flange)	ø58 mm
Shaft type	ø12 mm (blind hollow shaft)
Protection EN 60529	IP 65
Operating speed	≤8000 rpm (+20 °C, IP 65)
Starting torque	≤0.02 Nm (+20 °C, IP 65)
Material	Housing: aluminium die-cast Flange: aluminium
Operating temperature	-40...+100 °C
Relative humidity	90 % non-condensing
Resistance	EN 60068-2-6 Vibration 30 g, 10-2000 Hz EN 60068-2-27 Shock 250 g, 6 ms
Connection	Flange connector M23, 12-pin
Weight approx.	300 g

# EIL580P-BT12.5FF.01024.B

With blind hollow shaft, 1...65536 pulses per revolution programmable (interpolated system)

Article number: 11121825

## Terminal assignment

### Flange connector M23, 12-pin

Pin	Assignment
1	B-
2	-
3	R+
4	R-
5	A+
6	A-
7	R-Set <sup>1)</sup>
8	B+
9	-
10	GND
11	-
12	UB

<sup>1)</sup>The R-Set input is used to set the reference pulse (zero pulse) on the current shaft position.

R-Set = UB ≥ 200 ms

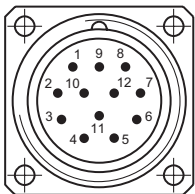

Flange connector M23, pin contacts, 12-pin, counterclockwise (CCW)

## Output signals

Zero pulse electrical 90° A&B high  
(Factory setting at clockwise rotation (CW)  
in view of the encoder flange)

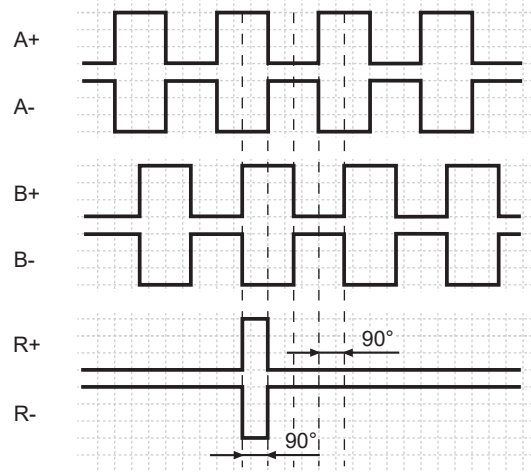

Zero pulse electrical 180° B low  
(at clockwise rotation (CW)  
in view of the encoder flange)

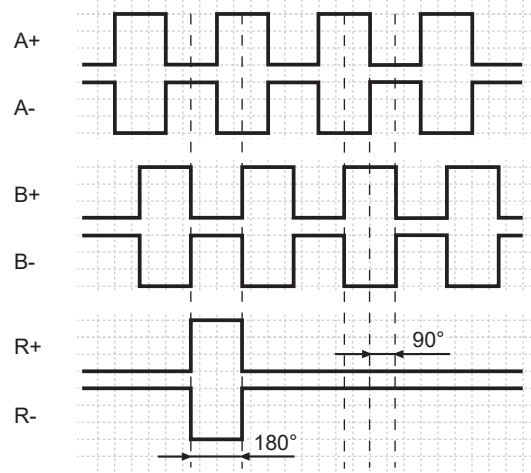

## Trigger level

Outputs	TTL/RS422
Output level High	≥2.5 V
Output level Low	≤0.5 V
Load	≤20 mA

  

Outputs	HTL/Push-pull
Output level High	≥UB -3 V
Output level Low	≤1.5 V
Load	≤20 mA

**Duty cycle**

The duty cycle (D) is defined as the time ratio between the HIGH pulse duration (H) and the pulse period (T).

System-induced and depending on the pulse number, the measured values may vary which has an impact on speed and position acquisition. Binary pulse numbers are recommended for speed feedback.

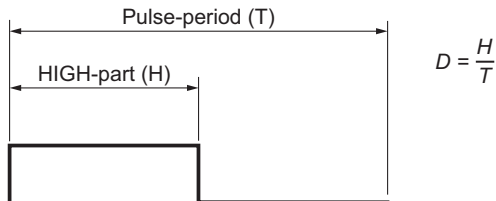

Programmed pulse number	Scan ratio (D) (maximum)	Jitter (+/-) (maximum)
1...1023	45...55 %	5%
1024, 2048	45...55 %	5%
1025...5000	40...60 %	10%
8192, 16384	35...85 %	15%
5001...10000	22...78 %	28%
32768	25...75 %	25%
65536	15...85 %	35%
all other	Jitter[%]=(programmed pulse number -10000)*0,0007%+28%	

# EIL580P-BT12.5FF.01024.B

With blind hollow shaft, 1...65536 pulses per revolution programmable (interpolated system)

Article number: 11121825

## Dimensions

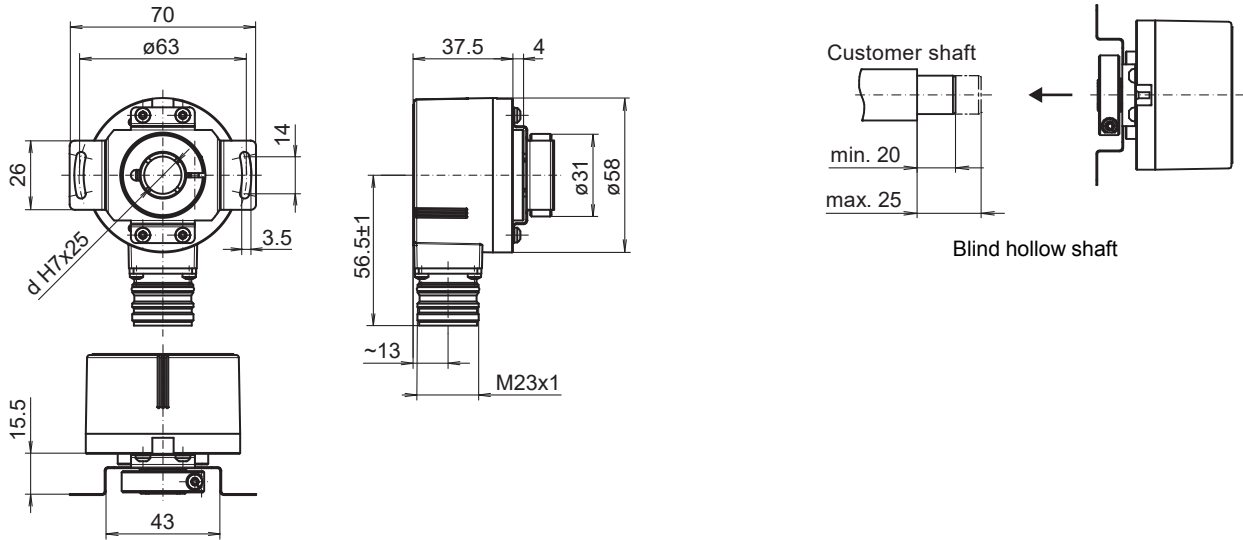

Clamping ring at A-side: Blind hollow shaft, flange connector M23 radial