

HART Transmitter Power Supply, Input Isolator

LB3005A2

- 4-channel
- Power supply for 2-wire transmitters with 4 mA ... 20 mA
- Installation in Zone 2 or safe area
- Supply circuit 15 V (20 mA)
- Input from active signals of 4-wire transmitters
- HART communication via field bus or service bus
- Simulation mode for service operations (forcing)
- Line fault detection (LFD): one LED per channel
- Permanently self-monitoring



Function

The transmitter power supply feeds 2-wire transmitters.
Active signals from separately powered field devices and 4-wire transmitters can be connected.
Open and short circuit line faults are detected.
The inputs are galvanically isolated from the bus and the power supply.

Wiring Diagram

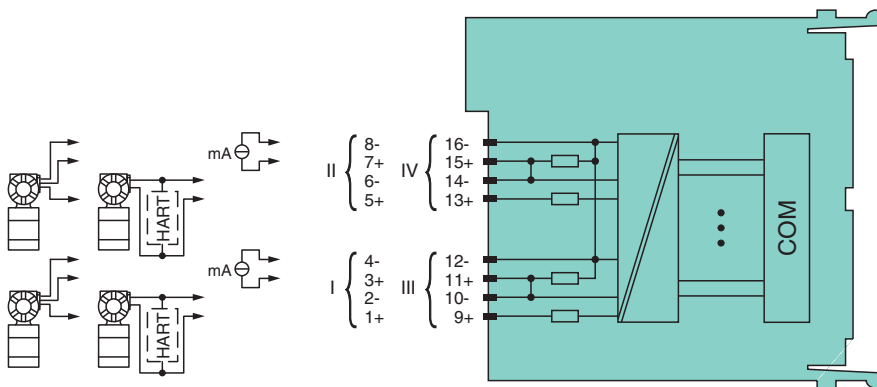

Zone 2

Technical Data

Slots	
Occupied slots	2
Supply	
Connection	backplane bus
Rated voltage	U_r 12 V DC , only in connection with the power supplies LB9***
Power dissipation	1.5 W
Power consumption	2.7 W
Internal bus	
Connection	backplane bus
Interface	manufacturer-specific bus to standard com unit
Analog input	

Release date: 2025-05-23 Date of issue: 2025-05-23 Filename: 254700_eng.pdf

Refer to "General Notes Relating to Pepperl+Fuchs Product Information".

Pepperl+Fuchs Group
www.pepperl-fuchs.com

USA: +1 330 486 0002
pa-info@us.pepperl-fuchs.com

Germany: +49 621 776 2222
pa-info@de.pepperl-fuchs.com

Singapore: +65 6779 9091
pa-info@sg.pepperl-fuchs.com

PEPPERL+FUCHS

Technical Data

Number of channels	4
Suitable field devices	
Field device	pressure converter
Field device [2]	flow converter
Field device [3]	level converter
Field device [4]	Temperature Converter
Field device interface	
Connection	2-wire transmitter
Connection [2]	3-wire transmitter
Connection [3]	4-wire transmitter
Connection	2-wire transmitter (HART):Supply circuit: channel I 1+, 2-, channel II 5+, 6-, channel III 9+, 10-, channel IV 13+, 14-3-wire transmitter:Supply circuit: channel I 1+, 4-, channel II 5+, 8-, channel III 9+, 12-, channel IV 13+, 16-Measurement loop: channel I 3+, 4-, channel II 7+, 8-, channel III 11+, 12-, channel IV 15+, 16-4-wire transmitter (powered externally):Measurement loop: channel I 3+, 4-, channel II 7+, 8-, channel III 11+, 12-, channel IV 15+, 16-
Transmitter supply voltage	min. 15 V at 20 mA ; 21.5 V at 4 mA
Input resistance	15 Ω
Conversion time	max. 100 ms
Line fault detection	can be switched on/off for each channel via configuration tool , configurable via configuration tool
Short-circuit	factory setting: > 22 mA configurable between 0 ... 26 mA
Open-circuit	factory setting: < 1 mA configurable between 0 ... 26 mA
HART communication	yes
HART secondary variable	no
Transfer characteristics	
Deviation	
After calibration	0.1 % of the signal range at 20 °C (68 °F)
Influence of ambient temperature	0.1 %/10 K of the signal range
Resolution	12 Bit (0 ... 26 mA)
Refresh time	100 ms
Indicators/settings	
LED indication	Power LED (P) green: supply Diagnostic LED (I) red: module fault , red flashing: communication error , white: fixed parameter set (parameters from com unit are ignored) , white flashing: requests parameters from com unit Status LED (1-4) red: line fault (lead breakage or short circuit)
Coding	optional mechanical coding via front socket
Directive conformity	
Electromagnetic compatibility	
Directive 2014/30/EU	EN 61326-1:2013
Conformity	
Electromagnetic compatibility	NE 21:2007
Degree of protection	IEC 60529:2000
Environmental test	EN 60068-2-14:2009
Shock resistance	EN 60068-2-27:2009
Vibration resistance	EN 60068-2-6:2008
Damaging gas	EN 60068-2-42:2003
Relative humidity	EN 60068-2-78:2001
Ambient conditions	
Ambient temperature	-40 ... 60 °C (-40 ... 140 °F) , 70 °C (non-Ex)
Storage temperature	-40 ... 85 °C (-40 ... 185 °F)
Relative humidity	95 % non-condensing
Altitude	max. 2000 m
Shock resistance	shock type I, shock duration 11 ms, shock amplitude 15 g, number of shocks 18

Release date: 2025-05-23 Date of issue: 2025-05-23 Filename: 254700_eng.pdf

Refer to "General Notes Relating to Pepperl+Fuchs Product Information".

Pepperl+Fuchs Group
www.pepperl-fuchs.comUSA: +1 330 486 0002
pa-info@us.pepperl-fuchs.comGermany: +49 621 776 2222
pa-info@de.pepperl-fuchs.comSingapore: +65 6779 9091
pa-info@sg.pepperl-fuchs.com

PEPPERL+FUCHS

Technical Data

Vibration resistance		frequency range 10 ... 150 Hz; transition frequency: 57.56 Hz, amplitude/acceleration ± 0.075 mm/1 g; 10 cycles frequency range 5 ... 100 Hz; transition frequency: 13.2 Hz amplitude/acceleration ± 1 mm/0.7 g; 90 minutes at each resonance
Damaging gas		designed for operation in environmental conditions acc. to ISA-S71.04-1985, severity level G3
Mechanical specifications		
Degree of protection		IP20 when mounted on backplane
Connection		removable front connector with screw flange (accessory) wiring connection via spring terminals (0.14 ... 1.5 mm ²) or screw terminals (0.08 ... 1.5 mm ²)
Mass		approx. 150 g
Dimensions		32.5 x 100 x 102 mm (1.28 x 3.9 x 4 inch)
Data for application in connection with hazardous areas		
Certificate		BVS 12 ATEX E 015 X
Supply		Ⓢ II 3G Ex nA [ic] IIC T4 Gc
Voltage	U _o	27 V
Current	I _o	90 mA
Power	P _o	588 mW (linear characteristic)
Input		
Voltage	U _o	0.7 V
Current	I _o	2.78 mA
Power	P _o	2 mW (trapezoid characteristic curve)
Voltage	U _i	30 V DC
Current	I _i	100 mA
Power	P _i	100 mW P _i < 100 mW is fulfilled by I _i < 100 mA, so a comparison of P _o < P _i is not necessary.
Internal capacitance	C _i	242 nF
Internal inductance	L _i	0 mH
Galvanic isolation		
Input/power supply, internal bus		safe electrical isolation acc. to EN 60079-11, voltage peak value 375 V
Directive conformity		
Directive 2014/34/EU		EN IEC 60079-0:2018+AC:2020 EN 60079-11:2012 EN 60079-15:2010
International approvals		
ATEX approval		BVS 12 ATEX E 105 X
IECEx approval		IECEx BVS 12.0055X
Approved for		Ex nA [ic] IIC T4 Gc
General information		
System information		The module has to be mounted in appropriate backplanes (LB9***) in Zone 2 or outside hazardous areas. Here, observe the corresponding declaration of conformity. For use in hazardous areas (e. g. Zone 2 or Zone 22) the module must be installed in an appropriate enclosure.
Supplementary information		EC-Type Examination Certificate, Statement of Conformity, Declaration of Conformity, Attestation of Conformity and instructions have to be observed where applicable. For information see www.pepperl-fuchs.com .

Assembly

Front view

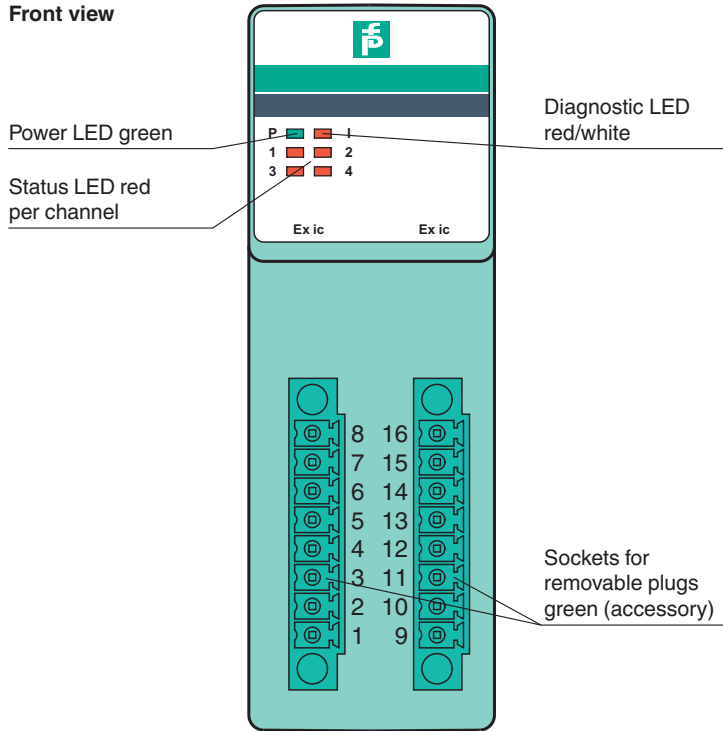

Release date: 2025-05-23 Date of issue: 2025-05-23 Filename: 254700_eng.pdf

Refer to "General Notes Relating to Pepperl+Fuchs Product Information".

Pepperl+Fuchs Group
www.pepperl-fuchs.com

USA: +1 330 486 0002
pa-info@us.pepperl-fuchs.com

Germany: +49 621 776 2222
pa-info@de.pepperl-fuchs.com

Singapore: +65 6779 9091
pa-info@sg.pepperl-fuchs.com