

EAM580R-SC0.7NC4.A3601.A

Solid shaft with clamping flange, magnetic singleturn encoder

Article number: 11205286

Overview

- Encoder singleturn / Analog
- E1 compliant design
- High protection IP 67
- High resistance to shock and vibrations
- Protection against corrosion CX (C5-M)
- Wire cross section 0,5 mm²
- Teach input for adjustment of measuring range
- Applicable up to PLd (ISO 13849)



Technical data

Technical data - electrical ratings

Voltage supply	14...30 VDC
Reverse polarity protection	Yes
Consumption typ.	20 mA (24 VDC, w/o load)
Initializing time	≤ 170 ms after power on
Response time	< 1 ms
Interface	Analog 0...10 V / 0.5...4.5 V / 4...20 mA / Resolution: 12 bit
Function	Singleturn
Teach range	5°...359.9° (singleturn)
Absolute accuracy	±0.15 ° (+20 ±15 °C) ±0.25 ° (-40...+85 °C) sensor
Accuracy analog output	±0.5 % of whole measuring range (-40...+85 °C)
Sensing method	Magnetic
Interference immunity	EN 61000-6-2 ISO 11452-2:2004* / -5:2002* ISO 7637-2:2004* ISO 10605:2008 + Amd 1:2014 (CD ±8 kV / AD ±15 kV) * Severity level according to ECE R10 (Rev. 4)
Emitted interference	EN 61000-6-4 CISPR 25:2008 (30...1000 MHz) ISO 7637-2:2004* * Severity level according to ECE R10 (Rev. 4)
MTTF _d (ISO 13849)	High (>100 years) Use in safety functions exclusively based on Application Note and MTTF _d reliability prediction (request separately).

Technical data - electrical ratings

Programmable parameters	Measuring range teachable
Diagnostic function	DATAVALID
Factory setting	360° and 10 revolutions (other on request)
Approval	UL approval / E217823

Technical data - mechanical design

Size (flange)	ø58 mm
Shaft type	ø10 x 20 mm, solid shaft with flat
Protection EN 60529	IP 67 (with shaft seal)
Operating speed	≤6000 rpm
Starting torque	≤2.5 Ncm (+20 °C, IP 67)
Moment of inertia	15.38 gcm ²
Admitted shaft load	≤40 N axial ≤80 N radial
Material	Housing: steel, powder-coated Flange: aluminium Shaft: stainless steel
Corrosion protection	IEC 60068-2-52 Salt mist for ambient conditions CX (C5-M) according to ISO 12944-2
Operating temperature	-40...+85 °C (see general information)
Relative humidity	95 %
Resistance	EN 60068-2-6 Vibration 30 g, 10-2000 Hz EN 60068-2-27 Shock 500 g, 1 ms
Weight approx.	250 g
Connection	Flange connector M12, 5-pin

General information

Self-heating interrelated to speed, protection, attachment method and ambient conditions as well electronics and supply voltage must be considered for precise thermal dimensioning. Self-heating is supposed to approximate 8 K (IP 67 protection) per 1000 rpm. Operating the encoder close to the maximum limits requires measuring the real prevailing temperature at the encoder flange. For the current output (version C4), a load >470 Ohm must be selected when supplied with 24 VDC in order to minimize the self-heating of the encoder and not to exceed the maximum operating temperature. For cable lengths >2 m, a current output (version C4) is to be preferred due to the voltage drop in order to avoid effects on the accuracy.

Terminal assignment

Flange connector M12, 5-pin

Pin	Signals	Description
1	0 V	Supply voltage
2	+Vs	Supply voltage
3	Uout/Iout	Analog output
4	DV	DATAVALID output
5	Teach	Teach input

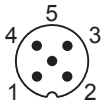

Cable

Core color	Signals	Description
white	0 V	Supply voltage
brown	+Vs	Supply voltage
green	Uout/Iout	Analog output
yellow	DV	DATAVALID output
grey	Teach	Teach input

Cable data: 5 x 0.5 mm²

Terminal significance

Iout	Current output Load: <500 Ω
Uout	Voltage output Current output: max. 10 mA Load resistor: >1 kΩ between Uout / 0 V (version 0...10 V) >2 kΩ (version 0.5...4.5 V)
Teach	Teach in Maximum 0...+Vs Level LOW: <1 V Level HIGH: >2.1 V
DV	Diagnostic output/Teach output Function normal operation: DATAVALID (Diagnostic output) Type NPN output, Pull-Up 10 kΩ integrated - No error: HIGH - Error: LOW Function teach process: Teach status

Output signals

Singleturn

Default: CW, 360°, rotating direction and measuring range teachable.

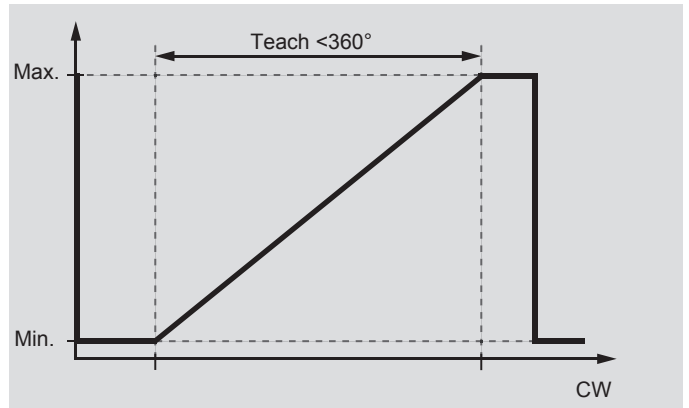
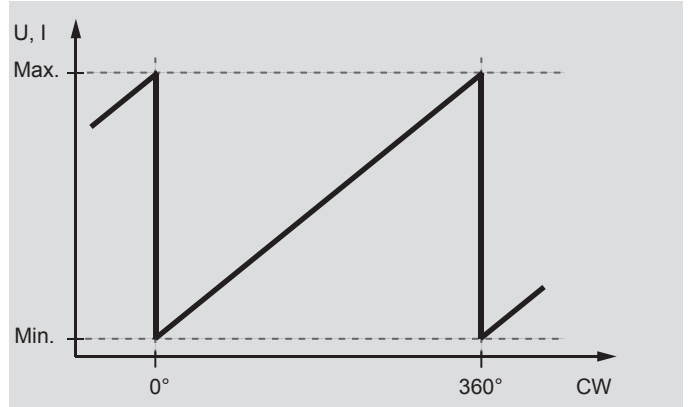

Multiturn

Default: CW, 10 turns, rotating direction and measuring range teachable (max. 32767 turns).

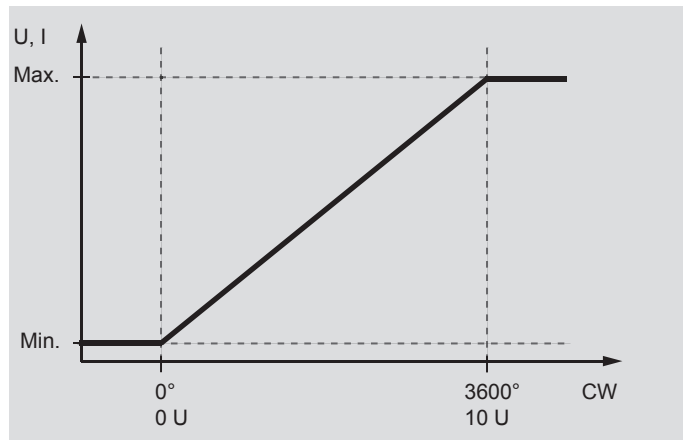

Note: The encoder can be mounted at a specific position and set to position 1 by means of factory preset.

Teach process**Activate teach process**

Start teach process within 5 minutes after power on. Set teach input for >5 seconds on HIGH and afterwards on LOW level.

DV/Status output: Oscillates after 5 seconds.

Position 1

Get encoder on position intended for min. voltage output / current output.

Set teach input for >0.1 seconds on HIGH.

DV/Status output: Switches to HIGH level for 3 seconds and flashes shortly.

Position 2

Get encoder on position intended for max. voltage output / current output.

Set teach input for >0.1 seconds on HIGH.

DV/Status output: Switches to HIGH level for 3 seconds and flashes shortly. If measuring range is exceeded or the limits are too close to each other, the teaching process was not successful and has to be repeated.

Default

Set teach input for >15 seconds on HIGH.

DV/Status output: Oscillates after 5 seconds.

EAM580R-SC0.7NC4.A3601.A

Solid shaft with clamping flange, magnetic singleturn encoder

Article number: 11205286

Dimensions

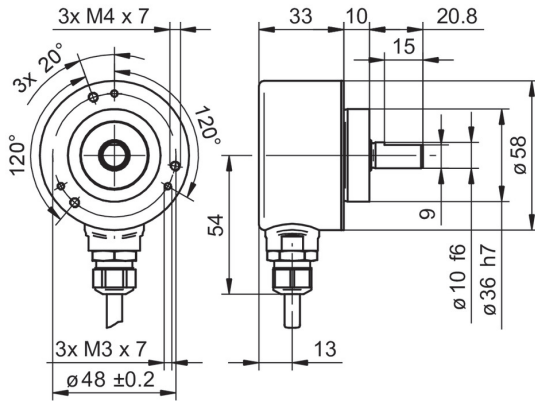

With cable

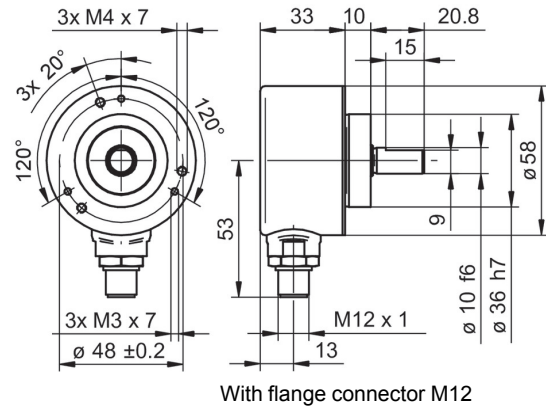

With flange connector M12

EAM580R-SC0.7NC4.A3601.A

Solid shaft with clamping flange, magnetic singleturn encoder

Article number: 11205286

Accessories**Mounting accessories**

11101893	Spring encoder arm
10125051	Mounting adaptor