

SD8600

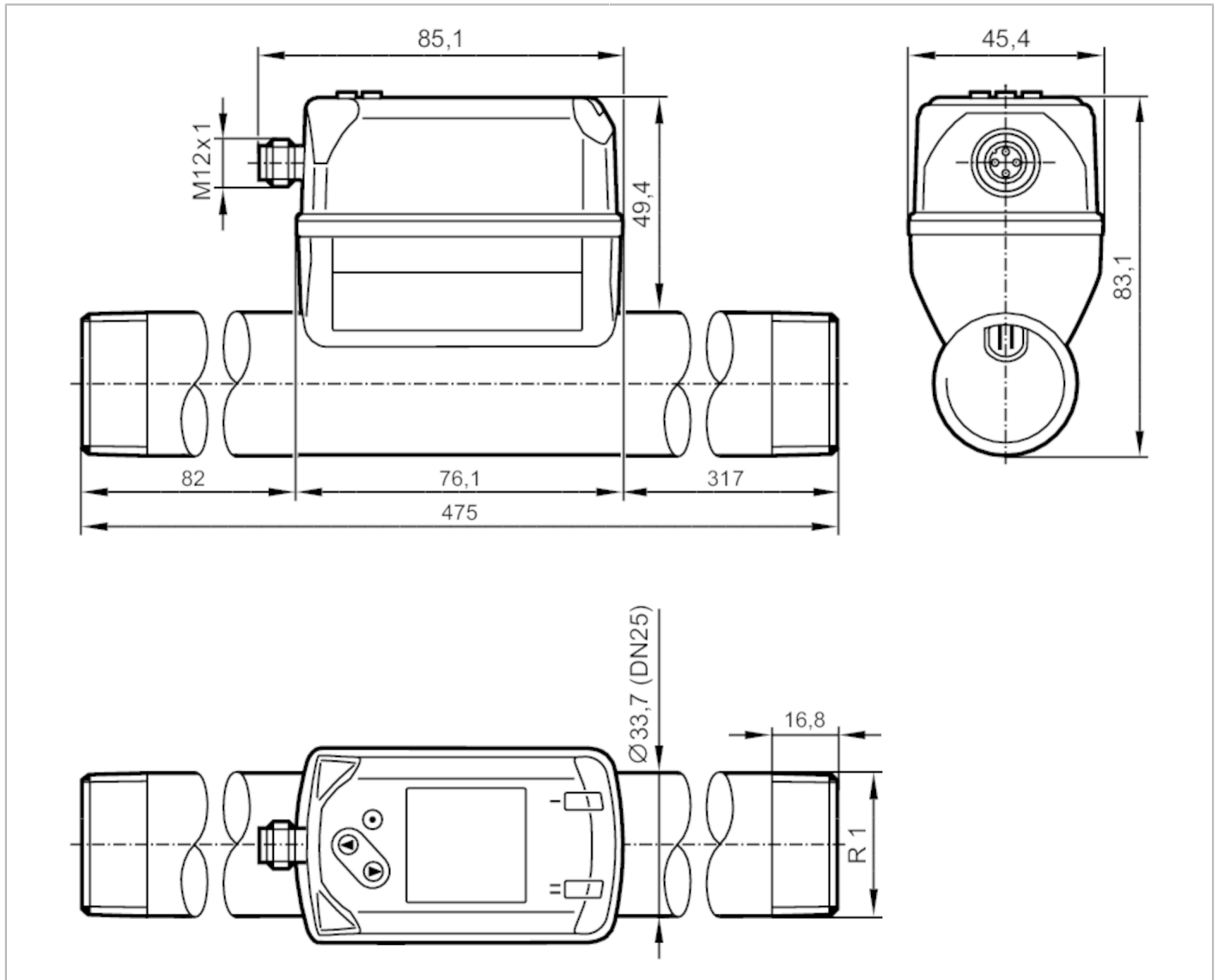

Industrial gas counter

SDR11DGXFRKG/US-100



Product characteristics

Number of inputs and outputs	Number of digital outputs: 2; Number of analogue outputs: 1		
Measuring range	14...3750 l/min	0.4...103.7 m/s	0.8...225 m³/h
Process connection	threaded connection R 1 external thread DN25		

Application

Application	for industrial applications		
Media	Argon (Ar); carbon dioxide (CO ₂); nitrogen (N ₂); compressed air		
Medium temperature [°C]	-10...60		
Min. burst pressure	64 bar	6.4 MPa	
Pressure rating	16 bar	1.6 MPa	
MAWP for applications according to CRN [bar]	10.5		

Electrical data

Operating voltage [V]	18...30 DC; (to SELV/PELV)		
-----------------------	----------------------------	--	--

SD8600



Industrial gas counter

SDR11DGXFRKG/US-100

Current consumption	[mA]	< 80
Protection class		III
Reverse polarity protection		yes
Power-on delay time	[s]	1

Inputs / outputs

Number of inputs and outputs	Number of digital outputs: 2; Number of analogue outputs: 1
------------------------------	---

Inputs

Inputs	counter reset
--------	---------------

Outputs

Output signal	switching signal; analogue signal; pulse signal; IO-Link; (configurable)
Electrical design	PNP/NPN
Number of digital outputs	2
Output function	normally open / normally closed; (parameterisable)
Max. voltage drop switching output DC	[V] 2.5
Permanent current rating of switching output DC	[mA] 150; (per output)
Number of analogue outputs	1
Analogue current output	[mA] 4...20; (scalable)
Max. load	[Ω] 500
Pulse output	consumed quantity meter
Short-circuit protection	yes
Type of short-circuit protection	pulsed
Overload protection	yes

Measuring/setting range

Measuring range	14...3750 l/min	0.4...103.7 m/s	0.8...225 m³/h
Display range	0...4500 l/min	0...124.4 m/s	0...270 m³/h
Resolution	2 l/min	0.1 m/s	0.1 m³/h
Set point SP	32...3749 l/min	0.9...103.7 m/s	1.9...224.9 m³/h
Reset point rP	14...3730 l/min	0.4...103.2 m/s	0.8...223.8 m³/h
Analogue start point ASP	0...3000 l/min	0...83 m/s	0...180 m³/h
Analogue end point AEP	750...3750 l/min	20.7...103.7 m/s	45...225 m³/h
Low flow cut-off LFC	4...40 l/min	0.1...1.1 m/s	0.3...2.4 m³/h
In steps of	1 l/min	0.1 m/s	0.1 m³/h

Pressure monitoring

Measuring range	[bar]	-1...16
Display range	[bar]	-1...20
Resolution	[bar]	0.05
Set point SP	[bar]	-0.92...16
Reset point rP	[bar]	-1...15.92
Analogue start point	[bar]	-1...12.8
Analogue end point	[bar]	2.2...16
In steps of	[bar]	0.01

SD8600



Industrial gas counter

SDR11DGXFRKG/US-100

Volumetric flow quantity monitoring		
Measuring range	0...100000000 m ³	0...353146667.2 scf
Display range	0...100000000 m ³	0...353146667.2 scf
Set point SP	0.001...10000000 m ³	0.05...353146667.2 scf
Pulse value	0.001...10000000 m ³	0.05...353146667.2 scf
In steps of	0.0001 m ³	0.005 scf
Pulse length [s]		0.007...2
Temperature monitoring		
Measuring range	-10...60 °C	14...140 °F
Display range	-24...74 °C	-11.2...165.2 °F
Resolution	0.2 °C	0.5 °F
Set point SP	-9.7...60 °C	14.6...140 °F
Reset point rP	-10...59.7 °C	14...139.4 °F
Analogue start point	-10...46 °C	14...114.8 °F
Analogue end point	4...60 °C	39.2...140 °F
In steps of	0.1 °C	0.1 °F
Accuracy / deviations		
Temperature coefficient [1/K]		± 0,07 % MW
Accuracy (in the measuring range)		± (6 % MW + 0,6 % MEW); at medium temperature 23 °C
Repeatability		± (0,4 % MW + 0,1 % MEW)
Pressure monitoring		
Repeatability [% of the final value]		± 0,2
Characteristics deviation [% of the final value]		< ± 0,5; (BFSL = Best Fit Straight Line)
Greatest TEMPCO of the span [% MEW / 10 K]		± 0,3
Greatest TEMPCO of the zero point [% MEW / 10 K]		± 0,1
Temperature monitoring		
Accuracy [K]		± 0,5; (medium flow in the limit area of the flow measurement range)
Response times		
Response time [s]		0.1; (dAP = 0)
Damping process value dAP [s]		0...5
Pressure monitoring		
Response time [s]		0.05
Temperature monitoring		
Dynamic response T05 / T09 [s]		T09 = 0,5
Software / programming		
Parameter setting options		hysteresis / window; normally open / normally closed; current/pulse output; display can be rotated and switched off; Display unit; totaliser
Interfaces		
Communication interface		IO-Link
Transmission type		COM2 (38,4 kBaud)

SD8600



Industrial gas counter

SDR11DGXFRKG/US-100

IO-Link revision	1.1	
SDCI standard	IEC 61131-9 CDV	
Profiles	Common - I&D	Identification and Diagnosis
	Function	Measurement data, standard resolution
SIO mode	yes	
Required master port type	A	
Process data analogue	8	
Process data binary	2	
Min. process cycle time [ms]	7.2	
Supported DeviceIDs	Type of operation	DeviceID
	default	868

Operating conditions		
Ambient temperature [°C]		0...60
Storage temperature [°C]		-20...85
Max. relative air humidity [%]		90
Protection		IP 65; IP 67

Tests / approvals		
EMC	DIN EN 60947-5-9	
CPA approval	model number	003TG
	accuracy class	-
	maximum allowable error	± 7 % FS
	Q (min)	0,8 m³/h
	Q (t)	-
	Q (max)	225 m³/h
Vibration resistance	DIN EN 68000-2-6	5 g (10...2000 Hz)
MTTF [years]		183
UL approval	UL approval no.	I012
	File number UL	E174189
Pressure Equipment Directive		Sound engineering practice; can be used for stable gases fluid group 2

Mechanical data		
Weight [g]		1530
Housing		rectangular
Dimensions [mm]		475 x 45.4 x 83.1
Materials		PBT+PC-GF30; PPS GF40; stainless steel (304/1.4301); stainless steel (303/1.4305); steel (1.5523) galvanised; 2.0401 (brass / CW614N); FKM
Materials (wetted parts)		stainless steel (304/1.4301); stainless steel (303/1.4305); FKM; ceramics glass passivated; PPS GF40; Al2O3 (ceramics); acrylate
Process connection		threaded connection R 1 external thread DN25

Displays / operating elements		
Display		colour display 1,44", 128 x 128 pixels 2 x LED, yellow

Remarks		
Remarks		MW = measured value MEW = Final value of the measuring range Standard conditions: 1013.25 mbar / 15 °C / 0 % relative humidity For information about installation and operation please see the operating instructions.

SD8600



Industrial gas counter

SDR11DGXFRKG/US-100

Pack quantity

1 pcs.

Electrical connection

Connector: 1 x M12; coding: A



Connection

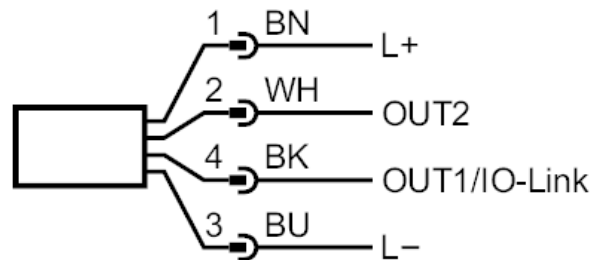

- OUT1/IO-Link: switching output flow
switching output temperature
switching output pressure
Pulse output quantity meter
signal output Preset counter
- OUT2/InD: switching output flow
switching output temperature
switching output pressure
analogue output flow
analogue output temperature
analogue output pressure
signal output Preset counter
Pulse output quantity meter
input counter reset