

SFOL-5M

**IP-Link Optical Fiber  
PUR Cable Jacket**

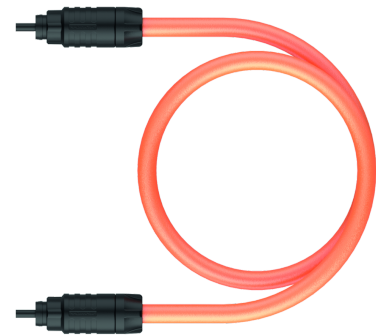
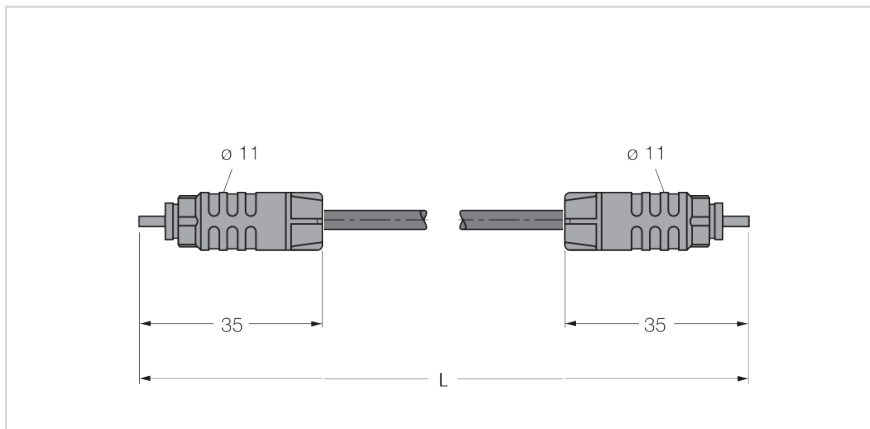

<b>Typ</b>	<b>SFOL-5M</b>
Ident-No.	6603386

**Technical data**

<b>Mechanical data</b>	
Bending cycles	≥2 Mio.
Bending radius	Ø55 mm
<b>Connector A</b>	
Protection class	Only in screwed condition
<b>Connector B</b>	
Protection class	Only when screwed together
<b>Cable</b>	
Cable diameter	5,5 mm
Cable length	5 m
Cable jacket	PUR, Orange
<b>Other properties</b>	
Qualified for drag chain use	yes
Halogen-free	yes
Oil-resistant	yes
<b>Comments</b>	
Packaging unit	1

**Features**

- POF optical fiber for IP-Link
- Fiber core PMMA 980 µm
- Fiber insulation PE 2.2 mm
- PUR jacket, 5.5 mm
- Muting (650 nm) < 190 dB/km
- Muting (660 nm) < 290 dB/km
- Numeric aperture 0.5
- Qualified for drag chain use
- Flame-retardant
- Halogen-free acc. to IEC60754
- Excellent resistance to oil, grease, acids and alkaline solutions
- Cable length: 5.0 m

**Functional principle**

The photoelectric sensor for IP-Link is a premoulded polymer optical fiber (POF) for the modular fieldbus I/O system piconet. The possibilities for industrial application range from static installations in cable ducts, pipes and racks up to dynamic installations such as dragchains.

The preassembled IP-Link fiber-optic cable together with the IP-Link socket of the piconet coupling and extension modules are a qualified IP67, shock and vibration tested combination.