

Product datasheet

Specifications



Regulated Power Supply, 100-240V AC, 12V 10 A, single phase, Optimized

ABLS1A12100

EAN Code: 3606481500229

Main

Range of product	Modicon Power Supply
Product or component type	Power supply
Power supply type	Regulated switch mode
Variant option	Optimized
Enclosure material	Aluminium
Nominal input voltage	100...240 V AC single phase 100...240 V AC phase to phase 140...340 V DC
Rated power in W	120 W
Output voltage	12 V DC
Power supply output current	10 A

Complementary

Input voltage limits	85...264 V AC without temperature derating 120...375 V DC without temperature derating
Nominal network frequency	50...60 Hz
Network system compatibility	TN TT IT
Maximum leakage current	1 mA 240 V AC
Input protection type	Integrated fuse (not interchangeable) 4 A External protection (recommended) 20 A Curve C External protection (recommended) 13 A Curve C
Inrush current	30.0 A at 115 V 60.0 A at 230 V
Power factor	0.55 at 115 V AC 0.45 at 230 V AC
Efficiency	84 % at 115 V AC 86 % at 230 V AC
Output voltage adjustment	11...14 V
Power dissipation in W	25 W
Current consumption	< 2.5 A 115 V AC < 1.4 A 230 V AC < 1.3 A 140 V DC
Turn-on time	< 1 s
Holding time	> 20 ms 115 V AC > 40 ms 230 V AC
Startup with capacitive loads	8000 µF

Disclaimer: This documentation is not intended as a substitute for and is not to be used for determining suitability or reliability of these products for specific user applications

Residual ripple	< 120 mV
Meantime between failure [MTBF]	700000 h at 25 °C, full load conforming to SR 332
Output protection type	Against overload and short-circuits, protection technology: automatic reset Against over temperature, protection technology: manual reset Against overvoltage, protection technology: manual reset
Connections - terminals	Screw connection: 0.5...4 mm ² , (AWG 20...AWG 12) without wire end ferrule for output Screw connection: 0.5...2.5 mm ² , (AWG 20...AWG 14) with wire end ferrule for output Screw connection: 0.75...4 mm ² , (AWG 18...AWG 12) without wire end ferrule for input Screw connection: 0.75...4 mm ² , (AWG 18...AWG 12) with wire end ferrule for input
Line and load regulation	< 0.5 % at 0 to 100 % load at 25 °C < 1 % at full voltage range in line at 25 °C
Status LED	1 LED (green) output voltage
Depth	117.6 mm
Height	123.6 mm
Width	40 mm
Net weight	0.52 kg
Output coupling	Parallel Serial
Mounting support	Top hat type TH35-15 rail conforming to IEC 60715 Top hat type TH35-7.5 rail conforming to IEC 60715 Double-profile DIN rail
Supply	SELV conforming to IEC 60950-1 SELV conforming to IEC 60204-1 SELV conforming to IEC 60364-4-41
Dielectric strength	3000 V AC with input to output
Service life	10 year(s)
Overvoltage category	II

Environment

Standards	IEC 62368-1 EN/IEC 61010-1 EN 61010-2-201 EN/IEC 61204-3 IEC 61000-6-1 IEC 61000-6-2 IEC 61000-6-3 IEC 61000-6-4 IEC 61000-3-2 EN 61000-3-3 UL 62368-1 UL 61010-1 UL 61010-2-201 CSA C22.2 No 62368-1 CSA C22.2 No 61010-1 CSA C22.2 No 61010-2-201
Product certifications	CE CUL listed CUL recognized RCM CB Scheme EAC KC
Operating altitude	< 5000 m
Shock resistance	150 m/s ² for 11 ms
IP degree of protection	IP20

Ambient air temperature for operation	-20...-10 °C with current derating of 2 % per °C mounting position A < 2000 m -10...40 °C without derating mounting position A 115 V AC < 2000 m -10...50 °C without derating mounting position A 230 V AC < 2000 m 40...70 °C with current derating of 1.67 % per °C mounting position A 115 V AC < 2000 m 50...70 °C with current derating of 2.5 % per °C mounting position A 230 V AC < 2000 m
Electrical shock protection class	Class I
Pollution degree	2
Vibration resistance	3 mm (f= 2...9 Hz) conforming to IEC 60068-2-6 10 m/s ² (f= 9...200 Hz) conforming to IEC 60068-2-6
Electromagnetic immunity	Immunity to electrostatic discharge - test level: 8 kV (contact discharge) conforming to IEC 61000-4-2 Immunity to electrostatic discharge - test level: 15 kV (air discharge) conforming to IEC 61000-4-2 Immunity to conducted RF disturbances - test level: 15 V/m (80 MHz...2 GHz) conforming to IEC 61000-4-3 Immunity to conducted RF disturbances - test level: 5 V/m (2...2.7 GHz) conforming to IEC 61000-4-3 Immunity to conducted RF disturbances - test level: 5 V/m (2.7...6 GHz) conforming to IEC 61000-4-3 Immunity to fast transients - test level: 4 kV (on input-output) conforming to IEC 61000-4-4 Surge immunity test - test level: 4 kV (between power supply and earth) conforming to IEC 61000-4-5 Surge immunity test - test level: 3 kV (between phases) conforming to IEC 61000-4-5 Immunity to conducted RF disturbances - test level: 15 V (0.15...80 MHz) conforming to IEC 61000-4-6 Immunity to magnetic fields - test level: 30 A/m (50...60 Hz) conforming to IEC 61000-4-8 Immunity to voltage dips conforming to IEC 61000-4-11 Disturbing field emission conforming to EN 55016-2-3 Limits for harmonic current emissions conforming to IEC 61000-3-2 conforming to EN 55016-1-2 conforming to EN 55016-2-1
Electromagnetic emission	Conducted emissions conforming to IEC 61000-6-3 Radiated emissions conforming to IEC 61000-6-4

Packing Units

Unit Type of Package 1	PCE
Number of Units in Package 1	1
Package 1 Height	5.4 cm
Package 1 Width	17.5 cm
Package 1 Length	18.0 cm
Package 1 Weight	674.0 g
Unit Type of Package 2	S03
Number of Units in Package 2	13
Package 2 Height	30.0 cm
Package 2 Width	30.0 cm
Package 2 Length	40.0 cm
Package 2 Weight	9.37 kg

Contractual warranty

Warranty (in months)	18
-----------------------------	----



Environmental Data

Schneider Electric aims to achieve Net Zero status by 2050 through supply chain partnerships, lower impact materials, and circularity via our ongoing “Use Better, Use Longer, Use Again” campaign to extend product lifetimes and recyclability.

[Environmental Data explained >](#)

[How we assess product sustainability >](#)



Environmental footprint

Total lifecycle Carbon footprint	1 249 kg CO2 eq.
Carbon footprint of the manufacturing phase [A1 to A3]	5 kg CO2 eq.
Carbon footprint of the distribution phase [A4]	0.2 kg CO2 eq.
Carbon footprint of the installation phase [A5]	0 kg CO2 eq.
Carbon footprint of the use phase [B2, B3, B4, B6]	1 243 kg CO2 eq.
Carbon footprint of the end-of-life phase [C1 to C4]	1 kg CO2 eq.

Use Better



Materials and Substances

Packaging made with recycled cardboard	No
Packaging without single use plastic	No
EU RoHS Directive	Pro-active compliance (Product out of EU RoHS legal scope)
SCIP Number	698d9b2a-7a6a-4b8f-a149-489156f55645
REACH Regulation	REACH Declaration

Use Longer



Lifetime extension

Repair	No
--------	----

Use Again



Repack and remanufacture

End of life manual availability	End of Life Information
Take-back	No
WEEE Label	 The product must be disposed on European Union markets following specific waste collection and never end up in rubbish bins

Dimensions Drawings

Electrical Safety

- If the unit is use in a manner not specified by the manufacturer, the protection provided by the equipment may be impaired.
- For means of disconnection a switch or circuit breaker, located near the product, must be included in the installation. A marking as disconnecting device for the product is required.
- The device has an internal fuse. The unit is tested and approved with branch circuit protective device up to 20A. This circuit breaker can be used as disconnecting device.
- The power supply is only suitable for audio, video, information, communication, industrial and control equipment.

Dimensions

Front and Side Views

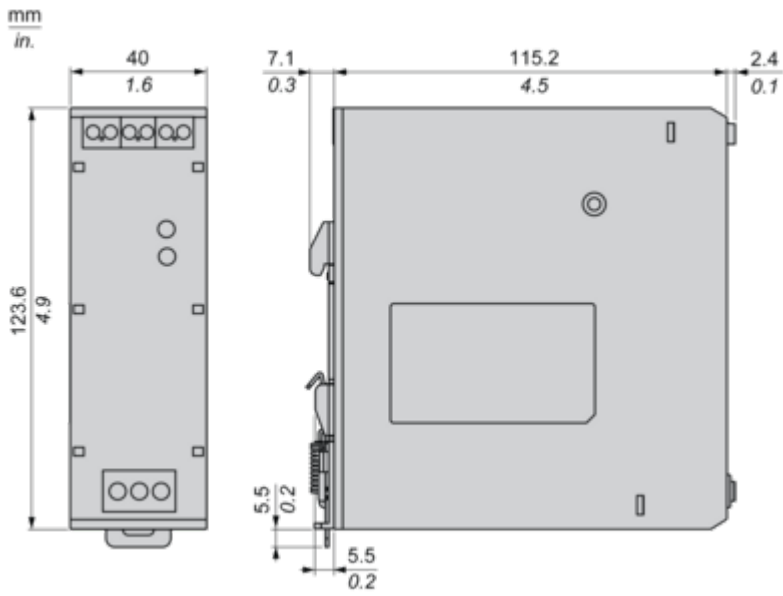

Connections and Schema

Connections and Schema

Correct Parallel Connection

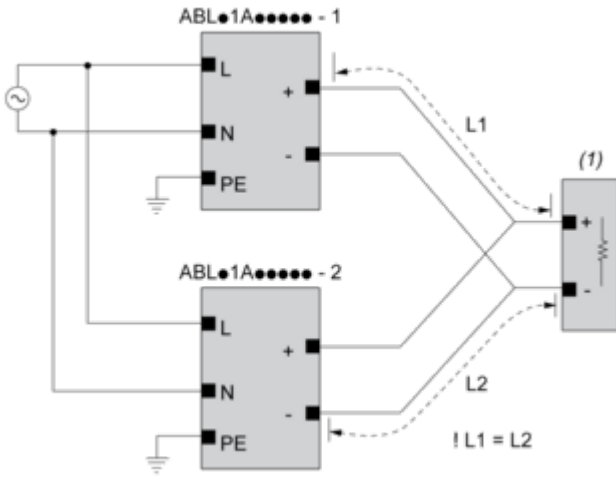

(1) : Load

Incorrect Parallel Connection

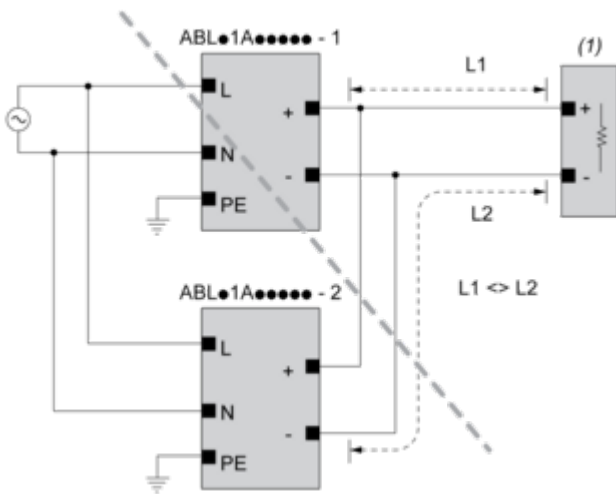

(1) : Load

$ABLx1Axxxx-1 = ABLx1Axxxx-2$

max 2 x ABLx1Axxxx

$L1 = L2$

ΔV max 25 mV

$I_{Load} < 90\% \cdot 2 \cdot I_{nom}$

Output Voltage Balancing

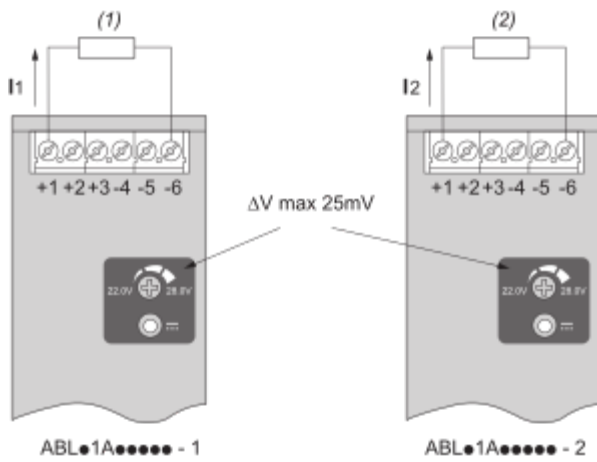

- (1) : R_{Load1}
- (2) : R_{Load2}
- $R_{Load1} = R_{Load2}$
- $I_1 = I_2 = \sim I_{nom}$

Series Connection

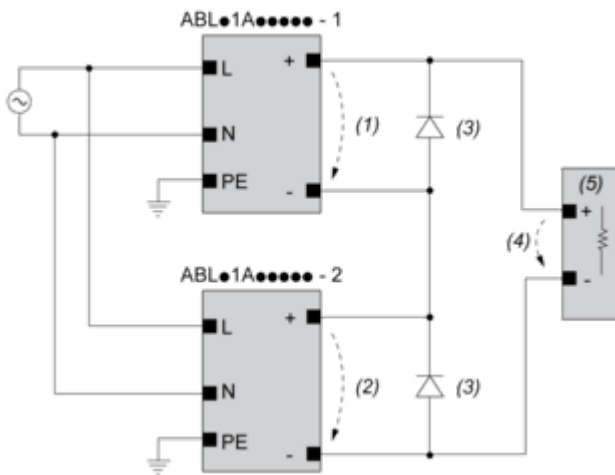

- (1) : V_{out1}
- (2) : V_{out2}
- (3) : 2 x Diode, $V_{RRM} > 2 \times V_{out1/2}$, $I_F > 2 \times I_{nom1/2}$
- (4) : $V_{Load} = 2 \times V_{out}$
- (5) : Load

Connections and Schema

	(1)		
	<40°C	<50°C	<70°C
ABLS1A24021	50°C	60°C	75°C
ABLS1A24038	50°C	60°C	75°C
ABLS1A12062	50°C	60°C	80°C
ABLS1A24031	50°C	60°C	80°C
ABLS1A12100	60°C	70°C	90°C
ABLS1A24050	60°C	70°C	90°C
ABLS1A48025	60°C	70°C	90°C
ABLS1A24100	60°C	70°C	90°C
ABLS1A24200	95°C	95°C	90°C

(1) : Ambient

Mounting and Clearance

Mounting

Mounting Position A

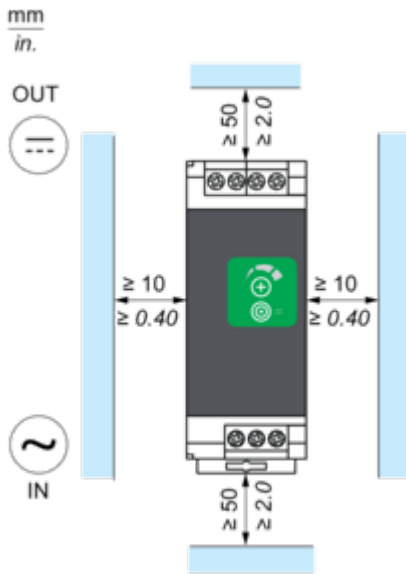

Mounting Position B

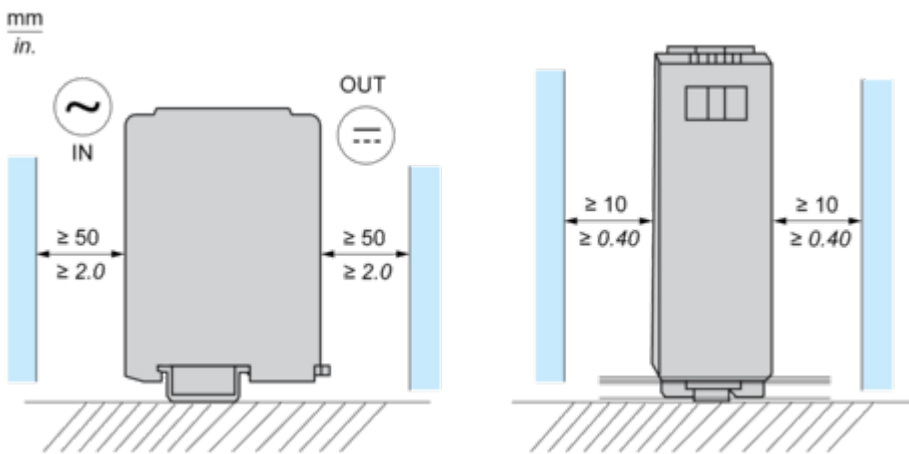

Incorrect Mounting

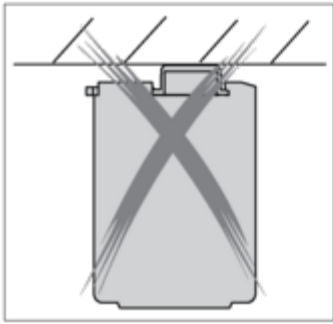
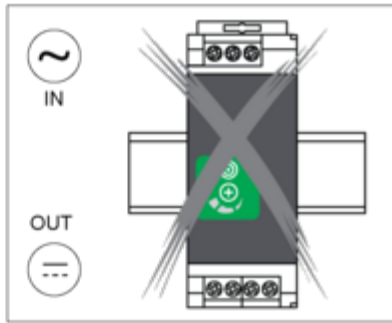
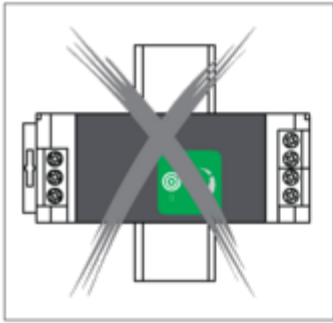

Performance Curves

Performance Curve

Mounting Position A

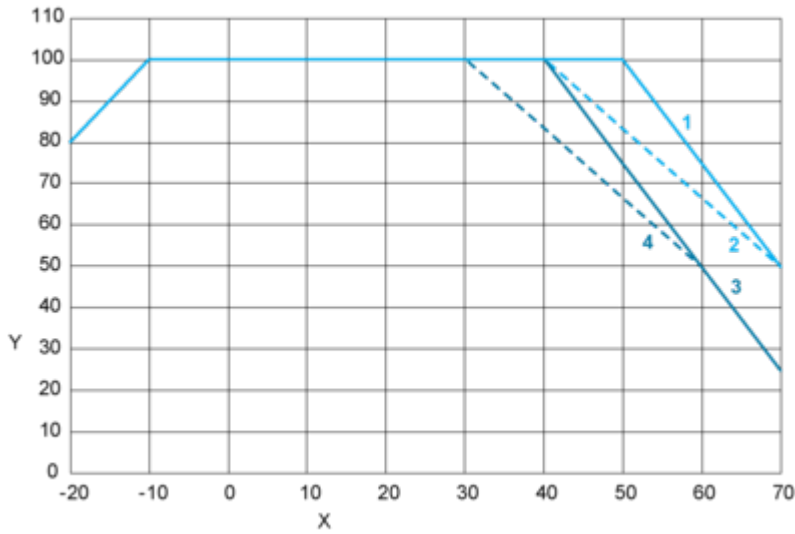

Mounting Position B

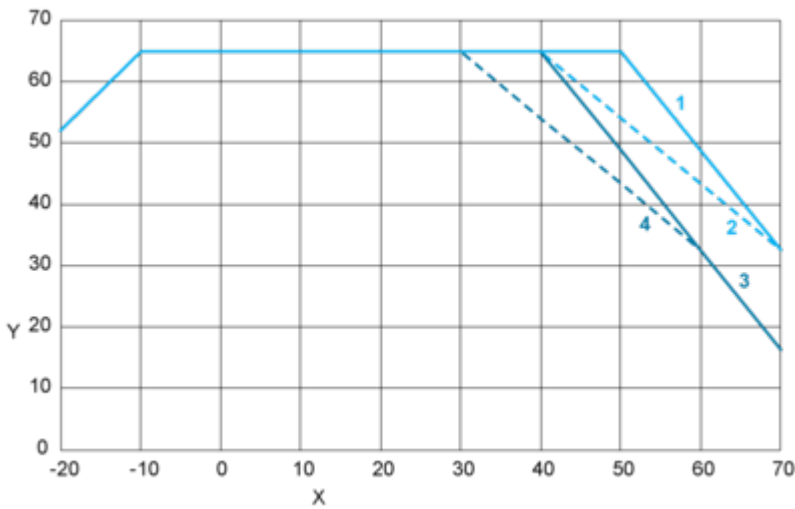

- X : Surrounding Air Temperature (°C)
- Y : Percentage of Maximum Load (%)
- 1 : Altitude ≤ 2000 m (6561 ft), Input voltage = 230 VAC / 325 VDC
- 2 : Altitude ≤ 2000 m (6561 ft), 115 VAC / 162 VDC
- 3 : Altitude ≤ 5000 m (16404 ft), Input voltage = 230 VAC / 325 VDC
- 4 : Altitude ≤ 5000 m (16404 ft), 115 VAC / 162 VDC

Image of product / Alternate images

Alternative





