

PSR-ESS-M0-H110 - Actuator



1221757

<https://www.phoenixcontact.com/gb/products/1221757>

Please be informed that the data shown in this PDF document is generated from our online catalog. Please find the complete data in the user documentation. Our general terms of use for downloads are valid.



Actuator with anti-lock collar for modular emergency stop switches, for combination with module holder and contact module as a functional unit, panel installation, bayonet lock

Product description

Phoenix Contact emergency stop switches are electromechanical switching devices with a safety function. They are used to safely shut down or stop machines and systems in order to prevent or minimize personal injury and property damage. The portfolio includes a modular system as well as a preconfigured solution. The modular emergency stop switch is comprised of the following components: - PSR-ESS-M0-H100 /...110 / ...120 actuator - PSR-ESS-ACC-CB1-C... module holder - PSR-ESS-ACC-CB1-NC-SC or PSR-ESS-ACC-CB1-SM-SC safe contact module Further contact modules can be combined if required.

Your advantages

- Modular system allows an efficient solution for individual applications
- Bayonet lock allows tool-free connection with the actuator
- Rapid on-site diagnostics with color-coded switching position indicator

Commercial data

Item number	1221757
Packing unit	1 pc
Minimum order quantity	1 pc
Sales key	DNA621
Product key	DNA621
GTIN	4063151310875
Weight per piece (including packing)	66.2 g
Weight per piece (excluding packing)	60.8 g
Country of origin	DE

Technical data

Notes

Note on application

Note on application	Only for industrial use
---------------------	-------------------------

Product properties

Product family	Modular emergency stop switches
----------------	---------------------------------

Electrical properties

Mechanical service life	50,000 switching cycles
-------------------------	-------------------------

Dimensions

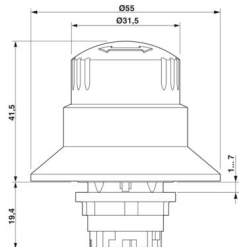
Dimensional drawing	
Depth	60.9 mm
Diameter	55 mm

Material specifications

Color (Mushroom head button)	red (RAL 3001)
Color (Front frame)	yellow (RAL 1018)
Flammability rating according to UL 94	V2
Housing material	PA

Environmental and real-life conditions

Ambient conditions

Degree of protection	IP65/IP67/IP69K (with professional installation in the appropriate installation space)
Ambient temperature (operation)	-30 °C ... 70 °C
Ambient temperature (storage/transport)	-50 °C ... 85 °C
Maximum altitude	max. 2000 m (Above sea level)
Shock	15g / 11 ms, in accordance with IEC 60068-2-27
Vibration (operation)	10 Hz ... 500 Hz, 0.35 mm amplitude, 5g, in accordance with IEC 60068-2-6

Mounting

Mounting type	Panel mount
---------------	-------------

PSR-ESS-M0-H110 - Actuator



1221757

<https://www.phoenixcontact.com/gb/products/1221757>

Assembly note	Mounting nut torque: max. 2.5 Nm
Mounting position	any
Mounting hole diameter	22.30 mm

Drawings

Dimensional drawing

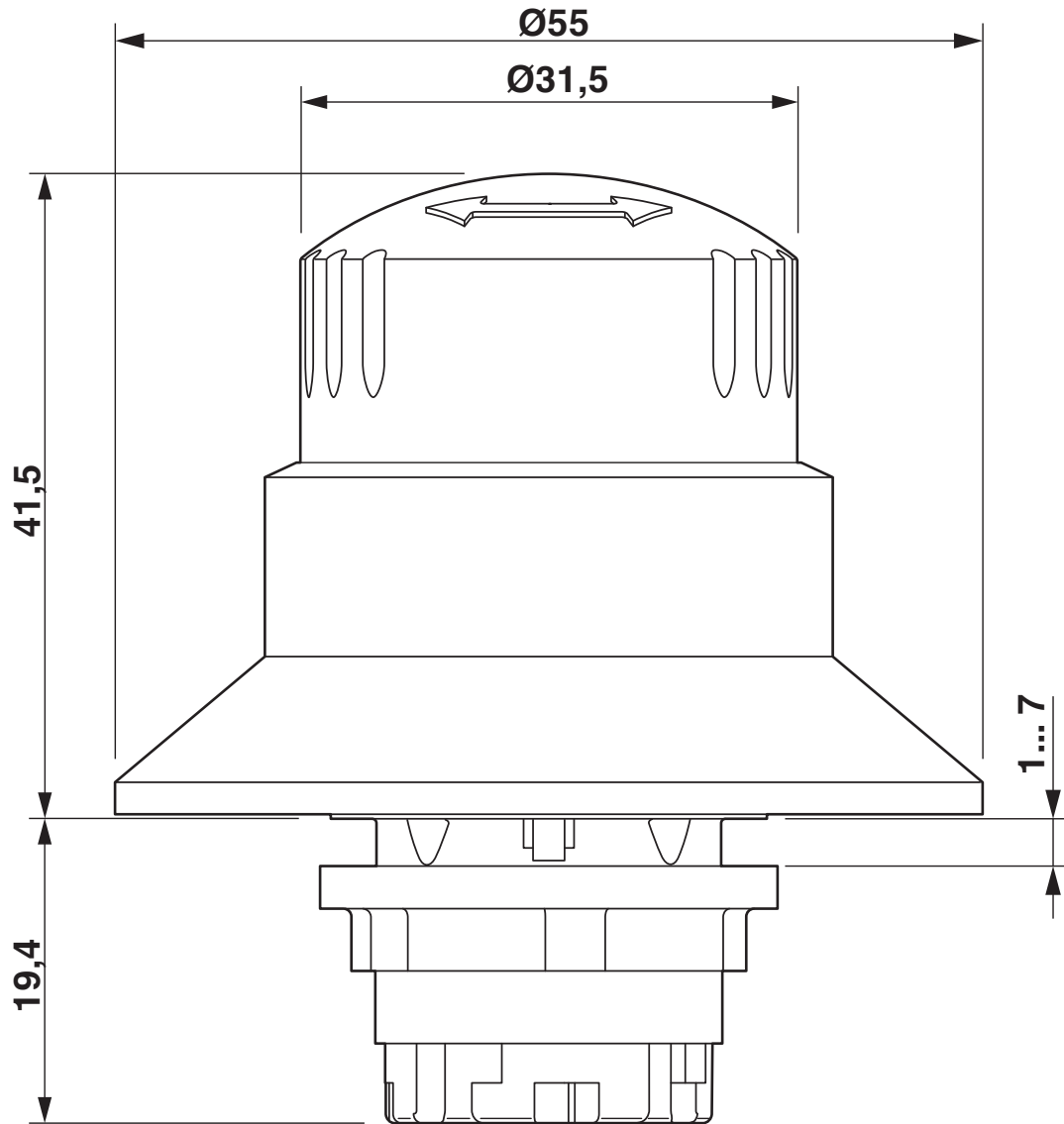

Dimensions (in mm)

1221757

<https://www.phoenixcontact.com/gb/products/1221757>

Approvals

To download certificates, visit the product detail page: <https://www.phoenixcontact.com/gb/products/1221757>



UL Recognized

Approval ID: E519465



UL Listed

Approval ID: E140324



cUL Listed

Approval ID: E140324



Functional Safety

Approval ID: B 029429 0031 Rev01

PSR-ESS-M0-H110 - Actuator



1221757

<https://www.phoenixcontact.com/gb/products/1221757>

Classifications

ECLASS

ECLASS-13.0	27371212
ECLASS-15.0	27371212

ETIM

ETIM 10.0	EC001038
-----------	----------

UNSPSC

UNSPSC 21.0	39122200
-------------	----------

PSR-ESS-M0-H110 - Actuator



1221757

<https://www.phoenixcontact.com/gb/products/1221757>

Environmental product compliance

EU RoHS

Fulfills EU RoHS substance requirements	Yes, No exemptions
---	--------------------

China RoHS

Environment friendly use period (EFUP)	EFUP-E
	No hazardous substances above the limits

EU REACH SVHC

REACH candidate substance (CAS No.)	No substance above 0.1 wt%
-------------------------------------	----------------------------

Phoenix Contact 2026 © - all rights reserved
<https://www.phoenixcontact.com>

PHOENIX CONTACT Ltd
Halesfield 13, Telford
Shropshire, TF7 4PG
01952 681700
info@phoenixcontact.co.uk