

VAL-CP-1S-175 - Type 2 surge arrester



2859479

<https://www.phoenixcontact.com/gb/products/2859479>

Please be informed that the data shown in this PDF document is generated from our online catalog. Please find the complete data in the user documentation. Our general terms of use for downloads are valid.



Plug-in surge arrester for 1-phase power supply networks with separate N and PE (3-conductor system: L1, N, PE), with remote indication contact.

Commercial data

Item number	2859479
Packing unit	1 pc
Minimum order quantity	1 pc
Product key	CL1311
GTIN	4046356045476
Weight per piece (including packing)	208.3 g
Weight per piece (excluding packing)	205.3 g
Country of origin	DE

VAL-CP-1S-175 - Type 2 surge arrester



2859479

<https://www.phoenixcontact.com/gb/products/2859479>

Technical data

Product properties

IEC test classification	II
	T2
EN type	T2
IEC power supply system	TN-S
	TT
Type	DIN rail module, two-section, divisible
Number of positions	2
Surge protection fault message	Optical, remote indicator contact

Insulation characteristics

Overvoltage category	III
Pollution degree	2

Electrical properties

Nominal frequency f_N	50 Hz (60 Hz)
Nominal voltage U_N	120 V AC

Indicator/remote signaling

Connection name	Remote fault indicator contact
Switching function	Changeover contact
Operating voltage	5 V AC ... 250 V AC
	125 V DC (200 mA DC)
Operating current	5 mA AC ... 1 A AC
	1 A DC (30 V DC)

Connection data

Connection method	Screw connection
Screw thread	M5
Tightening torque	4.5 Nm
Stripping length	16 mm
Conductor cross-section flexible	2.5 mm ² ... 16 mm ²
Conductor cross-section rigid	2.5 mm ² ... 25 mm ²
Conductor cross-section AWG	12 ... 4

Remote fault indicator contact

Connection method	Pluggable screw connection
Screw thread	M2
Tightening torque	0.25 Nm
Stripping length	7 mm
Conductor cross-section flexible	0.14 mm ² ... 1.5 mm ²
Conductor cross-section rigid	0.14 mm ² ... 1.5 mm ²
Conductor cross-section AWG	28 ... 16

VAL-CP-1S-175 - Type 2 surge arrester



2859479

<https://www.phoenixcontact.com/gb/products/2859479>

Dimensions

Dimensional drawing	
Width	25.3 mm
Height	98 mm
Depth	71.5 mm
Horizontal pitch	1.4 Div.

Material specifications

Flammability rating according to UL 94	V-0
CTI value of material	600
Insulating material	PBT-FR
Material group	I
Housing material	PBT-FR

Protective circuit

Mode of protection	L-N
	L-PE
	N-PE
Direction of action	1L-N & N-PE
Nominal voltage U_N	120 V AC (TN-S)
	120 V AC (TT)
Nominal frequency f_N	50 Hz (60 Hz)
Maximum continuous operating voltage U_C (L-N)	175 V AC
Maximum continuous operating voltage U_C (L-PE)	175 V AC
Maximum continuous operating voltage U_C (N-PE)	150 V AC
Rated load current I_L	40 A (Biconnect M4 fork-type cable lug 6 mm ²)
	63 A (TWIN ferrule 2 x 10 mm ²)
Protective conductor current I_{PE}	$\leq 1 \mu A$
Nominal discharge current I_n (8/20) μs (L-N)	20 kA
Nominal discharge current I_n (8/20) μs (N-PE)	20 kA
Maximum discharge current I_{max} (8/20) μs (L-N)	40 kA
Maximum discharge current I_{max} (8/20) μs (N-PE)	40 kA
Follow current interrupt rating I_{fi} (N-PE)	100 A (150 V AC)
Short-circuit current rating I_{SCCR}	25 kA
Voltage protection level U_p (L-N)	≤ 0.85 kV
Voltage protection level U_p (L-PE)	≤ 1.3 kV
Voltage protection level U_p (N-PE)	≤ 0.95 kV
	≤ 0.85 kV (at I_n)

VAL-CP-1S-175 - Type 2 surge arrester



2859479

<https://www.phoenixcontact.com/gb/products/2859479>

Residual voltage U_{res} (L-N)	≤ 0.75 kV (at 10 kA)
	≤ 0.65 kV (at 5 kA)
	≤ 0.63 kV (at 4 kA)
	≤ 0.57 kV (at 2 kA)
Residual voltage U_{res} (N-PE)	≤ 0.4 kV (at I_n)
	≤ 0.4 kV (at 10 kA)
	≤ 0.4 kV (at 5 kA)
	≤ 0.4 kV (at 4 kA)
	≤ 0.4 kV (at 2 kA)
TOV behavior at U_T (L-N)	240 V AC (5 s / withstand mode)
	240 V AC (120 min / safe failure mode)
TOV behavior at U_T (N-PE)	1200 V AC (200 ms / withstand mode)
Response time t_A (L-N)	≤ 25 ns
Response time t_A (N-PE)	≤ 100 ns
Max. backup fuse with V-type through wiring	40 A (gG / Biconnect M4 fork-type cable lug, 6 mm ²)
	63 A (gG / TWIN ferrule 2x 10mm ²)
Max. backup fuse with branch wiring	315 A (gG)

Environmental and real-life conditions

Ambient conditions

Degree of protection	IP20
Ambient temperature (operation)	-40 °C ... 80 °C
Ambient temperature (storage/transport)	-40 °C ... 80 °C
Altitude	≤ 2000 m (amsl)
Permissible humidity (operation)	5 % ... 95 %
Shock (operation)	30g (Half-sine / 11 ms / 3x $\pm X$, $\pm Y$, $\pm Z$)
Vibration (operation)	5g (10 ... 500 Hz / 2.5 h / X, Y, Z)

Approvals

UL specifications

Maximum continuous operating voltage MCOV (L-N)	175 V AC
Maximum continuous operating voltage MCOV (L-G)	175 V AC
Maximum continuous operating voltage MCOV (N-G)	150 V AC
Nominal discharge current I_n (L-N)	20 kA
Nominal discharge current I_n (L-G)	20 kA
Nominal discharge current I_n (N-G)	20 kA
Mode of protection	L-N
	L-G
	N-G
Nominal voltage	120 V AC
Power distribution system	Single phase
Nominal frequency	50/60 Hz
Measured limiting voltage MLV (L-N)	1510 V

VAL-CP-1S-175 - Type 2 surge arrester



2859479

<https://www.phoenixcontact.com/gb/products/2859479>

Measured limiting voltage MLV (L-G)	1630 V
Measured limiting voltage MLV (N-G)	560 V
Follow current (L-G)	200 A (150 V AC)
SPD Type	4CA

UL indicator/remote signaling

Operating voltage	125 V AC
AC operating current	1 A AC

UL connection data

Tightening torque	40 lb _F in. ... 50 lb _F in.
Conductor cross-section AWG	14 ... 2 (solid)
	14 ... 4 (flexible)

Standards and regulations

Air clearances and creepage distances

Standards/regulations	DIN VDE 0110-1 / IEC 60664-1 / IEC 61643-11 / UL 1449
Standards/specifications	IEC 61643-11
Note	2011
Standards/specifications	EN 61643-11
Note	2012

Mounting

Mounting type	DIN rail: 35 mm
---------------	-----------------

VAL-CP-1S-175 - Type 2 surge arrester

2859479

<https://www.phoenixcontact.com/gb/products/2859479>

Drawings

Dimensional drawing

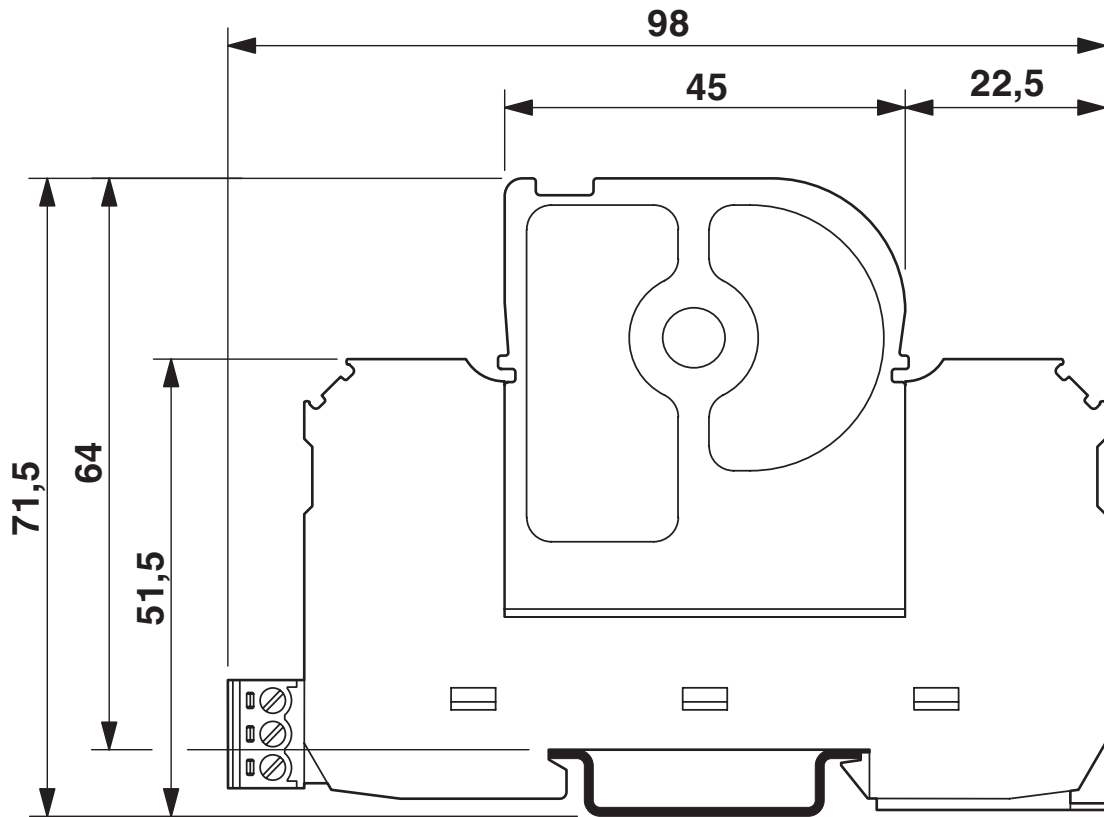

Circuit diagram

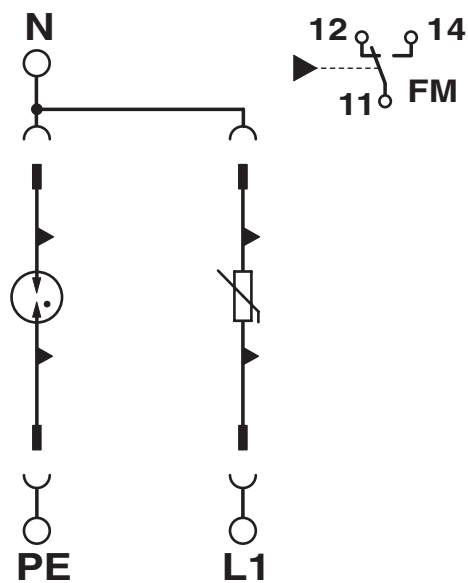

VAL-CP-1S-175 - Type 2 surge arrester



2859479

<https://www.phoenixcontact.com/gb/products/2859479>

Environmental product compliance

China RoHS

Environment friendly use period (EFUP)	EFUP-50
	An article-related China RoHS declaration table can be found in the download area for the respective article under "Manufacturer declaration". For all articles with EFUP-E, no China RoHS declaration table issued and required.

EU REACH SVHC

REACH candidate substance (CAS No.)	No substance above 0.1 wt%
-------------------------------------	----------------------------

Phoenix Contact 2026 © - all rights reserved
<https://www.phoenixcontact.com>

PHOENIX CONTACT Ltd
Halesfield 13, Telford
Shropshire, TF7 4PG
01952 681700
info@phoenixcontact.co.uk