

UPS-BAT/PB/24DC/1.2AH - Battery module



1274520

<https://www.phoenixcontact.com/gb/products/1274520>

Please be informed that the data shown in this PDF document is generated from our online catalog. Please find the complete data in the user documentation. Our general terms of use for downloads are valid.



Battery module (device with battery), VRLA-AGM, 24 V DC, 1.2 Ah, automatic detection and communication with QUINT UPS-IQ

Product description

For continuous monitoring and intelligent management, there is constant communication with the QUINT UPS. Thanks to automatic detection of the battery module and tool-free switching during operation, quick installation is possible. The battery modules for QUINT UPS with IQ Technology are fully charged before being sent to our warehouse.

Your advantages

- Maximum buffer times
- Lead AGM (Absorbent Glass Mat) technology

Commercial data

Item number	1274520
Packing unit	1 pc
Minimum order quantity	1 pc
Sales key	CMUEV3
Product key	CMUEV3
GTIN	4063151466640
Weight per piece (including packing)	2,275 g
Weight per piece (excluding packing)	1,840 g
Customs tariff number	85072080
Country of origin	CN

UPS-BAT/PB/24DC/1.2AH - Battery module



1274520

<https://www.phoenixcontact.com/gb/products/1274520>

Technical data

Notes

General

Note on the battery	This product contains a battery with a limited shelf life that must be charged every few months. The product packaging indicates when the battery must be started up or recharged. The general shelf life can be found in the energy storage devices area under "Latest startup".
---------------------	---

Energy storage

Input

Input voltage	24 V DC (SELV)
Nominal capacity	1.2 Ah
Charging current	0.36 A
End-of-charge voltage	27.6 V DC (20 °C)

Output

Output voltage	24 V DC
Output current	max. 15 A
Output fuse	1x 15 A
Buffer time	20 min (2 A) 5 min (5 A)

General

Connection in parallel	yes max. 5
Connection in series	no
Battery type	BB Battery BP1.2-12FR
Battery technology	VRLA-AGM
IQ-Technology	yes
Latest startup date (battery only)	3 Months (0 °C ... 20 °C) 1 Months (30 °C ... 40 °C)
Latest startup (battery only) - range	1 Months ... 3 Months (20 °C ... 30 °C)
Accumulator module service life (according to Eurobat)	6 (20 °C)
Size designation	Block
Battery pack	yes
Suitable for fast charging	yes
Temperature sensor	yes
Number of replacement battery kits	1x (UPS-BAT-KIT/PB/2X12V/1.2AH (1283114))

Connection data

Battery

Position	4.x
----------	-----

UPS-BAT/PB/24DC/1.2AH - Battery module



1274520

<https://www.phoenixcontact.com/gb/products/1274520>

Connection technology

Position marking	4.1 (+), 4.2 (-)
------------------	------------------

Conductor connection

Connection method	Screw connection
rigid	0.2 mm ² ... 4 mm ²
	2.5 mm ² ... 4 mm ² (recommended)
flexible	0.2 mm ² ... 2.5 mm ²
	2.5 mm ² (recommended)
AWG	24 ... 12
	14 ... 12 (recommended)
Stripping length	8 mm (recommended)
	8 mm
Tightening torque	0.5 Nm ... 0.6 Nm
	5 lb _f -in. ... 7 lb _f -in.
Drive form screw head	Slotted L

LIN

Position	4.x
----------	-----

Connection technology

Position marking	4.3 (┘┘  
------------------	---

Conductor connection

Connection method	Screw connection
rigid	0.2 mm ² ... 4 mm ² (LIN)
flexible	0.2 mm ² ... 2.5 mm ² (LIN)
AWG	24 ... 12 (LIN)
Stripping length	8 mm (LIN)
Tightening torque	0.5 Nm ... 0.6 Nm (LIN)
	5 lb _f -in. ... 7 lb _f -in. (LIN)
Drive form screw head	Slotted L

Product properties

Product family	Battery module (device with battery)
Application	for QUINT4 DC-UPS, QUINT-UPS, and TRIO-UPS-2G
Disposal	Used batteries must not be thrown away with household waste, they should instead be disposed of in accordance with applicable national regulations.

Insulation characteristics

Protection class	III
Degree of pollution	2

Dimensions

Item dimensions

UPS-BAT/PB/24DC/1.2AH - Battery module



1274520

<https://www.phoenixcontact.com/gb/products/1274520>

Width	54 mm
Height	157 mm
Depth	113 mm

Drill hole

Diameter	5 mm
----------	------

Installation dimensions

Installation distance right/left	0 mm / 0 mm
Installation distance top/bottom	5 mm / 5 mm

Mounting

Mounting position	horizontal DIN rail NS 35, EN 60715
-------------------	-------------------------------------

Material specifications

Housing material	Metal
Type of housing	Galvanized sheet steel, powder-coated

Environmental and real-life conditions

Ambient conditions

Degree of protection	IP20
Ambient temperature (storage/transport)	-20 °C ... 40 °C
Ambient temperature (charge)	0 °C ... 40 °C
Ambient temperature (discharge)	-20 °C ... 50 °C
Max. permissible relative humidity (operation)	≤ 95 %
Shock	15g, 11 ms, in each space direction (in accordance with IEC 60068-2-27)
Vibration (operation)	5 Hz ... 100 Hz, 0.7g (in accordance with DNV / IEC 60068-2-6)

Approvals

UL

Identification	UL/C-UL Listed UL 61010-1
----------------	---------------------------

UL

Identification	UL/C-UL Listed ANSI/UL 121201 Class I, Division 2, Groups A, B, C, D (Hazardous Location)
----------------	---

Shipbuilding

Identification	DNV
----------------	-----

Shipbuilding

Identification	ABS
----------------	-----

Shipbuilding

Identification	LR
----------------	----

Shipbuilding

UPS-BAT/PB/24DC/1.2AH - Battery module



1274520

<https://www.phoenixcontact.com/gb/products/1274520>

Identification	BV
----------------	----

Ex data

Suited for EX-applications	no
----------------------------	----

UPS-BAT/PB/24DC/1.2AH - Battery module



1274520

<https://www.phoenixcontact.com/gb/products/1274520>

Drawings

Block diagram

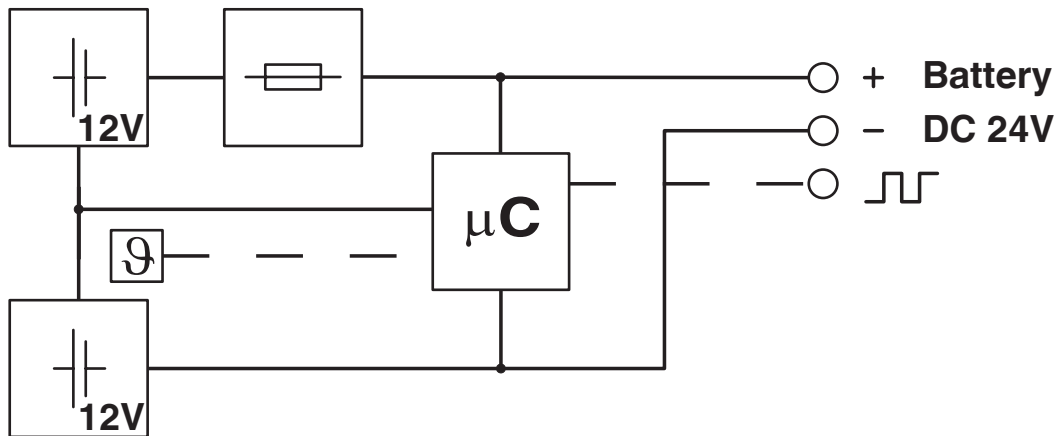

Block diagram

Graphic

Load Current	Buffertime																														
	Minutes										Hours																				
	1	2	3	4	5	6	7	8	9	10	20	30	40	45	50	1	2	3	4	5	6	7	8	9	10	12	14	16	18	20	50
1 A																							2x								
2 A																							2x								
3 A																							2x	2x	2x						
5 A																							2x	2x	2x	2x	2x				
7 A																							2x	2x	2x	2x	2x				
10 A																							2x	2x	2x	2x					
15 A																							2x	2x							
20 A																							2x	2x							
25 A																							2x								
30 A																							2x								
35 A																							2x	2x	2x						
40 A																							2x	2x	2x	2x					

2x: In this case, two battery modules of the same capacity are required. The data is based on an ambient temperature of +25 °C at the start of use.

- 1274520 UPS-BAT/PB/24DC/1.2AH
- 1274117 UPS-BAT/PB/24DC/4AH
- 1274118 UPS-BAT/PB/24DC/7AH
- 1274119 UPS-BAT/PB/24DC/12AH
- 1348516 UPS-BAT/PB/24DC/20AH
- 1354641 UPS-BAT/PB/24DC/40AH
- 1474660 UPS-BAT/PB/24DC/110AH

Lead battery buffer times for QUINT DC UPS

UPS-BAT/PB/24DC/1.2AH - Battery module



1274520

<https://www.phoenixcontact.com/gb/products/1274520>

Approvals

To download certificates, visit the product detail page: <https://www.phoenixcontact.com/gb/products/1274520>

ABS

Approval ID: 22-2244289-PDA



EAC

Approval ID: RU*DE*01.B.78948/21



cULus Listed

Approval ID: FILE E 123528



LR

Approval ID: LR22136091TA



BV

Approval ID: 41516/B0 BV

DNV

Approval ID: TAA0000265

	Nominal voltage U_N	Nominal current I_N	Cross section AWG	Cross section mm^2
keine				
	500 V	41 A	-	- 6



IECEE CB Scheme

Approval ID: DK-134807-A1-UL



cULus Listed

Approval ID: FILE E 199827

UPS-BAT/PB/24DC/1.2AH - Battery module



1274520

<https://www.phoenixcontact.com/gb/products/1274520>

Classifications

ECLASS

ECLASS-13.0	27050403
ECLASS-15.0	27050403

ETIM

ETIM 10.0	EC003893
-----------	----------

UNSPSC

UNSPSC 21.0	26111700
-------------	----------

1274520

<https://www.phoenixcontact.com/gb/products/1274520>

Environmental product compliance

EU RoHS

Fulfills EU RoHS substance requirements	Yes
Exemption	7(c)-I

China RoHS

Environment friendly use period (EFUP)	EFUP-8
	An article-related China RoHS declaration table can be found in the download area for the respective article under "Manufacturer declaration". For all articles with EFUP-E, no China RoHS declaration table issued and required.

EU REACH SVHC

REACH candidate substance (CAS No.)	Diboron trioxide(CAS: 1303-86-2)
	Lead monoxide (lead oxide)(CAS: 1317-36-8)
	Lead(CAS: 7439-92-1)
SCIP	db7d1870-c776-4a04-810c-10eed5bb3e7f

EF3.1 Climate Change

CO2e kg	20.89 kg CO2e
---------	---------------

Phoenix Contact 2026 © - all rights reserved

<https://www.phoenixcontact.com>

PHOENIX CONTACT Ltd
Halesfield 13, Telford
Shropshire, TF7 4PG
01952 681700
info@phoenixcontact.co.uk