

Product datasheet

Specifications



Harmony, Miniature plug-in relay pre-assembled, 6 A, 4 CO, with lockable test button, mixed terminals socket, 24 V DC

RXM4AB1BDPVM

EAN Code: 3606489563127

Main

Range of product	Harmony Electromechanical Relays
Series name	RXM series
Product or component type	Pre-assembled plug-in relay with socket
Relay type	Miniature relay
Contacts type and composition	4 C/O
Status LED	Without
Control type	Lockable test button
[Uc] control circuit voltage	24 V DC
[Ithe] conventional enclosed thermal current	6 A
Continuous output current	5 A

Complementary

[Uimp] rated impulse withstand voltage	2.5 kV during 1.2/50 μ s
[Ie] rated operational current	3 A at 28 V (DC) NC conforming to IEC 3 A at 250 V (AC) NC conforming to IEC 6 A at 28 V (DC) NO conforming to IEC 6 A at 250 V (AC) NO conforming to IEC 6 A at 277 V (AC) conforming to UL 8 A at 30 V (DC) conforming to UL
Minimum switching current	10 mA
Minimum switching voltage	17 V
Minimum switching capacity	170 mW at 10 mA, 17 V
Electrical durability	100000 cycles for resistive load
Rated operational voltage limits	19.2...26.4 V DC
[Ui] rated insulation voltage	250 V conforming to IEC
Maximum switching voltage	250 V
Drop-out voltage threshold	$\geq 0.1 U_c$ DC
Load current	6 A at 250 V AC 6 A at 28 V DC
Operating time	20 ms
Maximum switching capacity	1500 VA/168 W AC/DC
Average resistance	650 Ohm at 20 °C +/- 10 %
Average coil consumption	0.9 W, DC
Mechanical durability	1000000 cycles

Safety reliability data	B10d = 100000
Operating rate	<= 1200 cycles/hour under load <= 18000 cycles/hour no-load
Utilisation coefficient	20 %
CAD overall width	26.9 mm
CAD overall height	79 mm
CAD overall depth	78.45 mm
torque value	1 N.m
reset time	20 ms
Contact terminal arrangement	Mixed
Connections - terminals	Connector, 1 x 0.25...1 x 2.5 mm ² (AWG 22...AWG 14) flexible with cable end Connector, 2 x 0.25...2 x 1 mm ² (AWG 22...AWG 17) flexible with cable end Connector, 1 x 0.5...1 x 2.5 mm ² (AWG 20...AWG 14) solid without cable end Connector, 2 x 0.5...2 x 1.5 mm ² (AWG 20...AWG 16) solid without cable end
Dielectric strength	1300 V AC between contacts with micro disconnection 2000 V AC between coil and contact with basic insulation 2000 V AC between poles with basic insulation
Compatibility code	RXM
Protection category	RT I
Pollution degree	2
Operating position	Any position
Test levels	Level A group mounting
Device presentation	Complete product
Sale per indivisible quantity	30
Contacts material	AgNi
Shape of pin	Flat (faston type)
Net weight	0.096 kg

Environment

Ambient air temperature for operation	-40...55 °C
IP degree of protection	IP20 conforming to IEC 60529
Standards	UL 508 IEC 61810-1 CSA C22.2 No 14 IEC 61984
Product certifications	UL Lloyd's CE CSA GOST IECEE CB Scheme
Ambient air temperature for storage	-40...85 °C
Vibration resistance	3 gn, amplitude = +/- 1 mm (f = 10...150 Hz)5 cycles in operation 5 gn, amplitude = +/- 1 mm (f = 10...150 Hz)5 cycles not operating
Shock resistance	10 gn for in operation 30 gn for not operating

Packing Units

Unit Type of Package 1	PCE
-------------------------------	-----

Number of Units in Package 1	1
Package 1 Height	2.500 cm
Package 1 Width	8.000 cm
Package 1 Length	8.000 cm
Package 1 Weight	92.000 g
Unit Type of Package 2	BB1
Number of Units in Package 2	30
Package 2 Height	10.000 cm
Package 2 Width	25.000 cm
Package 2 Length	29.600 cm
Package 2 Weight	3.110 kg
Unit Type of Package 3	S03
Number of Units in Package 3	60
Package 3 Height	30.000 cm
Package 3 Width	30.000 cm
Package 3 Length	40.000 cm
Package 3 Weight	7.125 kg

Logistical informations

Country of origin	ID
--------------------------	----

Contractual warranty

Warranty (in months)	18
-----------------------------	----



Environmental Data

Schneider Electric aims to achieve Net Zero status by 2050 through supply chain partnerships, lower impact materials, and circularity via our ongoing “Use Better, Use Longer, Use Again” campaign to extend product lifetimes and recyclability.

[Environmental Data explained >](#)

[How we assess product sustainability >](#)



Environmental footprint

Total lifecycle Carbon footprint	15 kg CO2 eq.
Environmental Disclosure	Product Environmental Profile
Carbon footprint of the manufacturing phase [A1 to A3]	0.7 kg CO2 eq.
Carbon footprint of the distribution phase [A4]	0 kg CO2 eq.
Carbon footprint of the installation phase [A5]	0 kg CO2 eq.
Carbon footprint of the use phase [B2, B3, B4, B6]	14 kg CO2 eq.
Carbon footprint of the end-of-life phase [C1 to C4]	0 kg CO2 eq.

Use Better



Materials and Substances

Packaging made with recycled cardboard	Yes
Packaging without single use plastic	Yes
EU RoHS Directive	Pro-active compliance (Product out of EU RoHS legal scope)
REACH Regulation	REACH Declaration

Use Longer



Lifetime extension

Repair	No
--------	----

Use Again



Repack and remanufacture

End of life manual availability	End of Life Information
Take-back	No

Dimensions Drawings

Dimensions

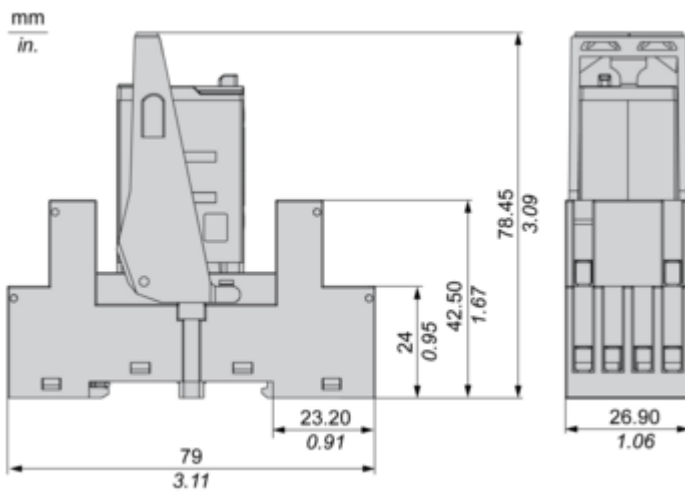

Connections and Schema

Wiring Diagram



Symbols shown in blue correspond to Nema marking.

Performance Curves

Electrical Durability of Contacts

Durability (inductive load) = durability (resistive load) x reduction coefficient.
Resistive AC load

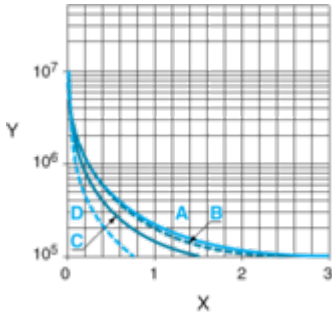

- X Switching capacity (kVA)
- Y Durability (Number of operating cycles)
- A RXM2AB...
- B RXM3AB...
- C RXM4AB...
- D RXM4GB...

Reduction coefficient for inductive AC load (depending on power factor $\cos \phi$)

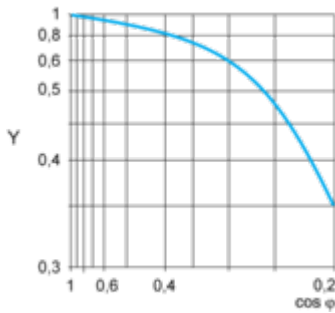

- Y Reduction coefficient (A)
- Maximum switching capacity on resistive DC load

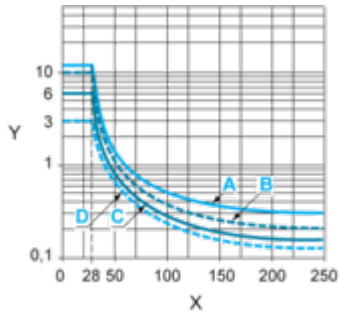

- X Voltage DC
- Y Current DC
- A RXM2AB...
- B RXM3AB...
- C RXM4AB...
- D RXM4GB...

Note : These are typical curves, actual durability depends on load, environment, duty cycle, etc.
For inductive load, to increase relay life cycles, please add a proper load protection circuit (eg: RC protection/Varistor/free Wheeling diode -DC load only-).
For low level loads (below 10mA), we recommend to use RXM*GB series with bifurcated contacts relays instead.

Technical Illustration

Dimensions

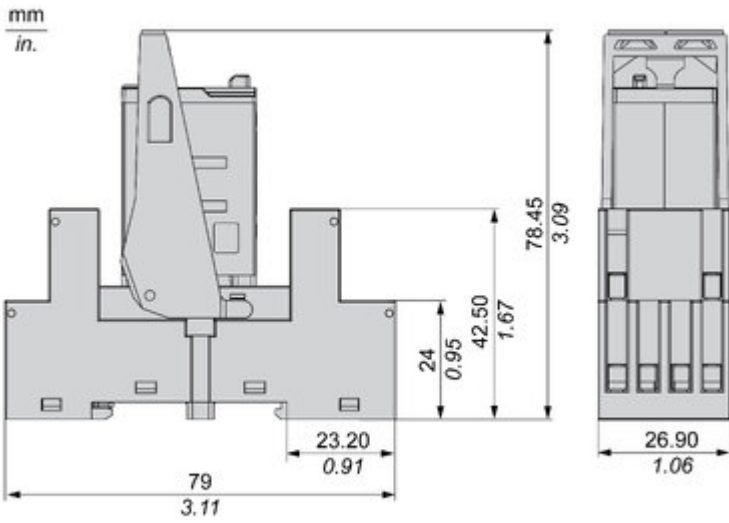

Offer Marketing Illustration

Product benefits / Features

Technical Benefits

Harmony RXMAB Relay

RXM*AB sockets:

- Mixed or separate contact arrangement
- Push-in, screw clamp or screw connector terminal

Plastic or metal maintaining clamp to protect against vibration

RXM*AB relays:

- 2CO-12A, 3CO-10A, 4CO-6A
- 12-220VDC, 24-240VAC

Push button (Blue for DC, Red for AC) and lockable test button for contact testing

Mechanical indicator for relay contact status

"Power On" LED for relay status



Offer Marketing Illustration

Product benefits / Features

Features

Harmony RXMAB Relay



- 

Pluggable relay module for easy replacement and retrofitting of relays
- 

Conforms to international standards: IEC, CE, UL, CSA, EAC, Lloyd's, RoHS and REACH
- 

Save time and cost with pre-assembled relays and push-in sockets
- 

Add-on protection modules and timer relay for flexibility

Image of product / Alternate images

Alternative

