

Product datasheet

Specifications



discrete module X80 - 8 NO Type A - Isolated relays - 125 V DC/250 V AC

BMXDRA0815

EAN Code: 3606481275608

Main

Range of product	Modicon X80
Product or component type	Relay discrete output module
Discrete output number	8 conforming to IEC 61131-2
Discrete output type	Relay
Discrete output logic	Positive
Discrete output voltage	24...240 V 19...264 V AC 24...125 V 5...150 V DC

Complementary

Electrical connection	20 ways terminal block
Network frequency	50/60 Hz
Network frequency limits	47...63 Hz
Sensor power supply	5...150 V 19...264 V
[I _{th}] conventional free air thermal current	3 A
Insulation resistance	> 10 MOhm 500 V DC
Power dissipation in W	3.6 W
Response time on output	<= 10 ms activation <= 13 ms deactivation
Typical current consumption	40 mA at 3.3 V DC 101 mA at 24 V DC
MTBF reliability	3200000 H
Protection type	External short-circuit protection External overload protection External overvoltage protection, inductive AC network External overvoltage protection, inductive DC network
Output overload protection	Use 1 fast blow fuse per channel or group of channel
Output overvoltage protection	Use discharge diode on each output DC Use RC circuit on each output AC Use ZNO surge limiter on each output AC
Output short-circuit protection	Use 1 fast blow fuse per channel or group of channel
Minimum switching current	1 mA 5 V DC

Disclaimer: This documentation is not intended as a substitute for and is not to be used for determining suitability or reliability of these products for specific user applications

Electrical durability	AC-12: 200000 cycles at 48 VA 24 V at 0...60 °C AC-12: 300000 cycles at 48 VA 48 V at 0...60 °C AC-12: 150000 cycles at 96 VA 48 V at 0...60 °C AC-12: 300000 cycles at 110 VA 100...120 V at 0...60 °C AC-12: 150000 cycles at 220 VA 100...120 V at 0...60 °C AC-12: 300000 cycles at 220 VA 200...250 V at 0...60 °C AC-12: 150000 cycles at 500 VA 200...250 V at 0...60 °C AC-15: 700000 cycles at 10 VA 24 V at 0...60 °C (load factor 0.4) AC-15: 500000 cycles at 24 VA 24 V at 0...60 °C (load factor 0.4) AC-15: 200000 cycles at 48 VA 24 V at 0...60 °C (load factor 0.4) AC-15: 700000 cycles at 10 VA 48 V at 0...60 °C (load factor 0.4) AC-15: 500000 cycles at 24 VA 48 V at 0...60 °C (load factor 0.4) AC-15: 300000 cycles at 48 VA 48 V at 0...60 °C (load factor 0.4) AC-15: 100000 cycles at 96 VA 48 V at 0...60 °C (load factor 0.4) AC-15: 1000000 cycles at 10 VA 100...120 V at 0...60 °C (load factor 0.4) AC-15: 300000 cycles at 50 VA 100...120 V at 0...60 °C (load factor 0.4) AC-15: 200000 cycles at 110 VA 100...120 V at 0...60 °C (load factor 0.4) AC-15: 70000 cycles at 220 VA 100...120 V at 0...60 °C (load factor 0.4) AC-15: 1000000 cycles at 10 VA 200...250 V at 0...60 °C (load factor 0.4) AC-15: 500000 cycles at 50 VA 200...250 V at 0...60 °C (load factor 0.4) AC-15: 200000 cycles at 110 VA 200...250 V at 0...60 °C (load factor 0.4) AC-15: 150000 cycles at 220 VA 200...250 V at 0...60 °C (load factor 0.4) DC-12: 200000 cycles at 24 W 24 V at 0...60 °C DC-12: 150000 cycles at 48 W 24 V at 0...60 °C DC-12: 150000 cycles at 40 W 48...60 V at 0...60 °C DC-12: 100000 cycles at 45 W 100...125 V at 0...60 °C DC-13: 100000 cycles at 10 W 24 V at 0...60 °C DC-13: 60000 cycles at 24 W 24 V at 0...60 °C DC-13: 40000 cycles at 48 W 24 V at 0...60 °C DC-13: 40000 cycles at 40 W 48...60 V at 0...60 °C DC-13: 100000 cycles at 15 W 100...125 V at 0...60 °C
------------------------------	--

Status LED	1 LED (green) RUN 1 LED per channel (green) channel diagnostic 1 LED (red) ERR 1 LED (red) I/O
-------------------	---

Net weight	0.169 kg
-------------------	----------

Environment

IP degree of protection	IP20
Dielectric strength	1780 V AC at 50/60 Hz 1 min
Vibration resistance	3 gn
Shock resistance	30 gn
Ambient air temperature for storage	-40...85 °C
Ambient air temperature for operation	0...60 °C
Relative humidity	5...95 % at 60 °C without condensation
Protective treatment	Standard version
Operating altitude	0...2000 m 2000...5000 m with derating factor

Packing Units

Unit Type of Package 1	PCE
Number of Units in Package 1	1
Package 1 Height	5.700 cm
Package 1 Width	11.700 cm
Package 1 Length	11.700 cm
Package 1 Weight	200.000 g
Unit Type of Package 2	S02
Number of Units in Package 2	15

Package 2 Height	15.000 cm
Package 2 Width	30.000 cm
Package 2 Length	40.000 cm
Package 2 Weight	3.319 kg

Logistical informations

Country of origin	FR
-------------------	----

Contractual warranty

Warranty (in months)	18
----------------------	----



Environmental Data

Schneider Electric aims to achieve Net Zero status by 2050 through supply chain partnerships, lower impact materials, and circularity via our ongoing “Use Better, Use Longer, Use Again” campaign to extend product lifetimes and recyclability.

[Environmental Data explained >](#)

[How we assess product sustainability >](#)



Environmental footprint

Total lifecycle Carbon footprint	157 kg CO2 eq.
Carbon footprint of the manufacturing phase [A1 to A3]	26 kg CO2 eq.
Carbon footprint of the distribution phase [A4]	0 kg CO2 eq.
Carbon footprint of the installation phase [A5]	0.1 kg CO2 eq.
Carbon footprint of the use phase [B2, B3, B4, B6]	131 kg CO2 eq.
Carbon footprint of the end-of-life phase [C1 to C4]	0.4 kg CO2 eq.
Environmental Disclosure	Product Environmental Profile

Use Better



Materials and Substances

Packaging made with recycled cardboard	Yes
EU RoHS Directive	Compliant By Exemption
REACH Regulation	Reference contains Substances of Very High Concern above the threshold

Use Longer



Lifetime extension

Repair	No
--------	----

Use Again



Repack and remanufacture

Recyclability potential, in %	3
End of life manual availability	End of Life Information
Take-back	Nej

Dimensions Drawings

Modules Mounted on Racks

Dimensions



(1) With removable terminal block (cage, screw or spring).

(2) With FCN connector.

(3) On AM1 ED rail: 35 mm wide, 15 mm deep. Only possible with BMXXBP0400/0400H/0600/0600H/0800/0800H rack.

Rack references	a in mm	a in in.
BMXXBP0400 and BMXXBP0400H	242.4	09.54
BMXXBP0600 and BMXXBP0600H	307.6	12.11
BMXXBP0800 and BMXXBP0800H	372.8	14.68
BMXXBP1200 and BMXXBP1200H	503.2	19.81

Connections and Schema

Connecting the Module

Output Circuit Diagram

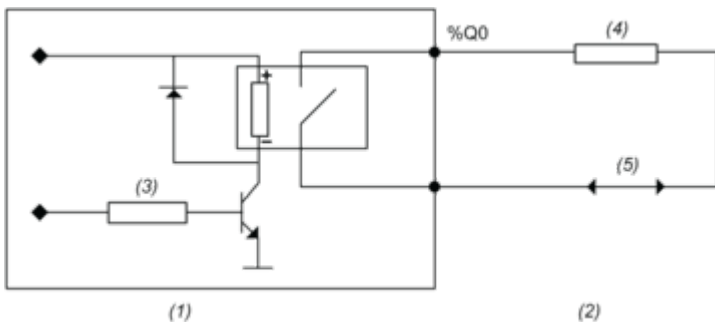

- (1) Module
- (2) Output
- (3) Command
- (4) Pre-actuator
- (5) Power supply

Module Connection

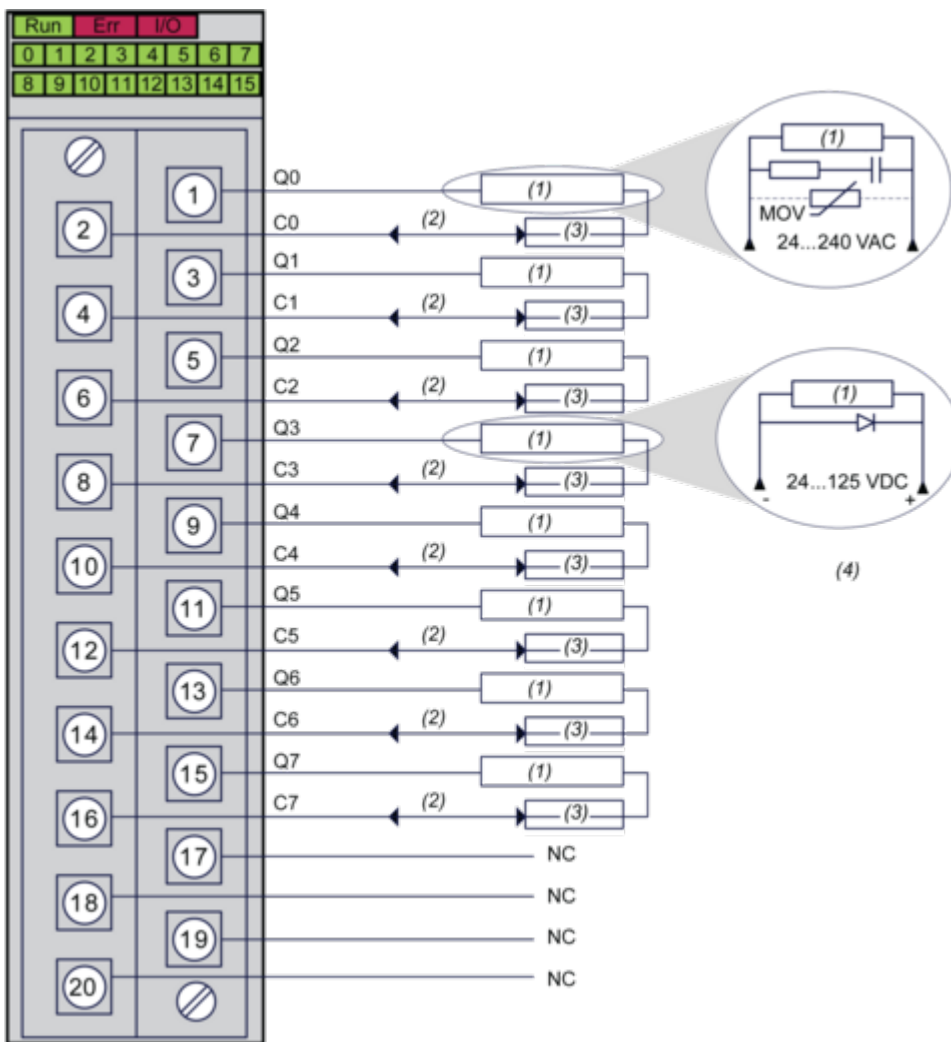

- (1) Pre-actuator
- (2) Power supply : 24...125 Vdc or 24...240 Vac

(3) Fuse : Use appropriate fast-blow fuse for each relay

(4) We recommend installing this type of protection on the terminals of each pre-actuator

N/C : Not connected

Image of product / Alternate images

Alternative

