

# EKM36-0KF0A018A

EKS/EKM36

MOTOR FEEDBACK SYSTEMS

**SICK**  
Sensor Intelligence.

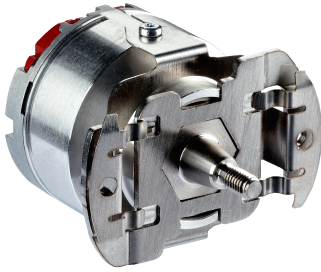

Illustration may differ

### Ordering information

Type	part no.
EKM36-0KF0A018A	1053849

Other models and accessories → [www.sick.com/EKS\\_EKM36](http://www.sick.com/EKS_EKM36)

### Detailed technical data

#### Performance

<b>Resolution per revolution</b>	18 bit
<b>Number of the absolute ascertainable revolutions</b>	4,096
<b>Measuring step per revolution</b>	262,144
<b>Signal noise (<math>\sigma</math>)</b>	$\pm 5^\circ$ <sup>1)</sup>
<b>Error limits positional values integral non-linearity in angular seconds</b>	$\pm 80$
<b>Error limits positional values differential non-linearity in angular seconds</b>	$\pm 40$
<b>Max. speed when switching on and resetting the motor feedback system</b>	$\leq 6,000 \text{ min}^{-1}$
<b>Available memory area</b>	8,192 Byte

<sup>1)</sup> See diagrams 1 and 2.

#### Interfaces

<b>Type of code for the absolute value</b>	Binary
<b>Code sequence</b>	Increasing, when turning the shaft For clockwise rotation, looking in direction "A" (see dimensional drawing)
<b>Communication interface</b>	HIPERFACE DSL®
<b>Initialization time</b>	Max. 500 ms <sup>1)</sup>
<b>Measurement external temperature resistance</b>	32 bit value, without prefix (1 $\Omega$ ) 0 ... 209.600 $\Omega$ At $-40^\circ \text{C}$ ... $+160^\circ \text{C}$ : NTC $+2\text{K}$ ; PTC $+3\text{K}$
<b>Available memory area</b>	8,192 Byte

<sup>1)</sup> From reaching a permitted operating voltage.

#### Electrical data

<b>Supply voltage range</b>	7 V ... 12 V
<b>Warm-up time voltage ramp</b>	Max. 180 ms <sup>1)</sup>
<b>Operating current</b>	Max. 150 mA (see diagram 3) <sup>2)</sup> 150 mA

<sup>1)</sup> Duration of voltage ramp between 0 and 7.0 V.

<sup>2)</sup> Current rating applies when using interface circuit suggestions as shown in HIPERFACE DSL® manual (8017595).

<b>Output frequency for the digital position value</b>	0 kHz ... 75 kHz
--	------------------

<sup>1)</sup> Duration of voltage ramp between 0 and 7.0 V.

<sup>2)</sup> Current rating applies when using interface circuit suggestions as shown in HIPERFACE DSL ® manual (8017595).

## Mechanical data

<b>Shaft version</b>	Tapered shaft
<b>Flange type / stator coupling</b>	Stator coupling
<b>Dimensions</b>	See dimensional drawing
<b>Weight</b>	0.1 kg
<b>Moment of inertia of the rotor</b>	4.5 gcm <sup>2</sup>
<b>Operating speed</b>	12,000 U/min
<b>Operating torque</b>	0.2 Ncm
<b>Start up torque</b>	0.3 Ncm
<b>Permissible shaft movement, radial static/dynamic</b>	± 0.1 mm / ± 0.05 mm
<b>Permissible shaft movement, axial static/dynamic</b>	± 0.1 mm
<b>Life of ball bearings</b>	3.6 x 10 <sup>9</sup> revolutions
<b>Connection type</b>	Connector, 4-pin

## Ambient data

<b>Operating temperature range</b>	-20 °C ... +115 °C <sup>1)</sup>
<b>Storage temperature range</b>	-40 °C ... +125 °C
<b>Resistance to shocks</b>	100 g, 6 ms (according to EN 60068-2-27)
<b>Frequency range of resistance to vibrations</b>	50 g, 10 Hz ... 2,000 Hz (EN 60068-2-6)
<b>EMC</b>	According to EN 61000-6-2, EN 61000-6-4 and IEC 61326-3 <sup>2)</sup>
<b>Enclosure rating</b>	IP50, with mating connector inserted and closed cover (acc. to EN 60529-1) <sup>3)</sup>

<sup>1)</sup> Given typical thermal connection between motor flange and encoder stator coupling. The max. internal sensor temperature may not exceed 125 °C.

<sup>2)</sup> The EMC according to the standards quoted is achieved when the motor feedback system is mounted in an electrically conductive housing, which is connected to the central earthing point of the motor controller via a cable screen. The GND-(0 V) connection of the supply voltage is also grounded here. If other shielding concepts are used, users must perform their own tests.

<sup>3)</sup> With mating connector inserted and closed cover.

## Classifications

<b>ECLASS 5.0</b>	27270590
<b>ECLASS 5.1.4</b>	27270590
<b>ECLASS 6.0</b>	27270590
<b>ECLASS 6.2</b>	27270590
<b>ECLASS 7.0</b>	27270590
<b>ECLASS 8.0</b>	27270590
<b>ECLASS 8.1</b>	27270590
<b>ECLASS 9.0</b>	27270590
<b>ECLASS 10.0</b>	27273805
<b>ECLASS 11.0</b>	27273901
<b>ECLASS 12.0</b>	27273901

<b>ETIM 5.0</b>	EC001486
<b>ETIM 6.0</b>	EC001486
<b>ETIM 7.0</b>	EC001486
<b>ETIM 8.0</b>	EC001486
<b>UNSPSC 16.0901</b>	41112113

### Dimensional drawing EKx36-xxFOA0xxA

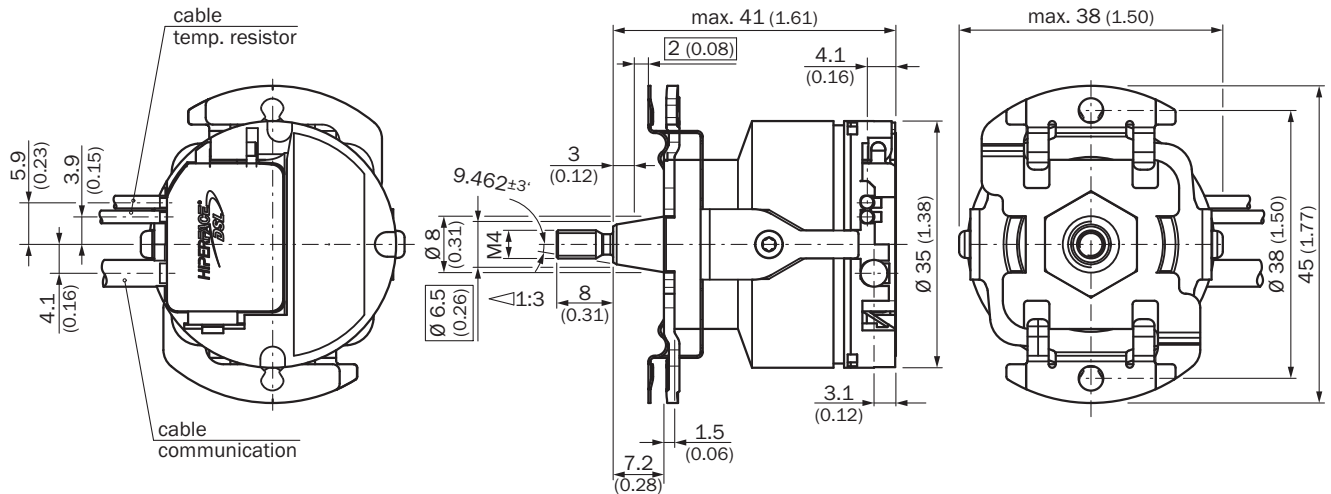

Dimensions in mm (inch)

### Attachment specifications

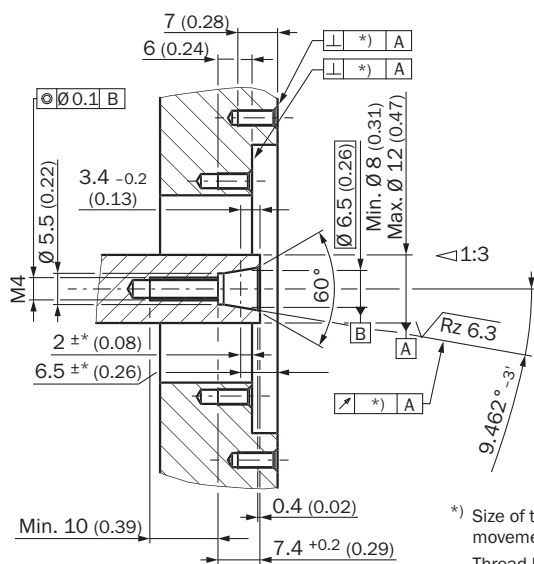

\*) Size of tolerance reduce the allowed movement of the shaft, see data sheet.  
Thread holes according DIN 13 with counterbore according DIN 76 min. 1.05 x diameter of thread.

- ① Nominal position
- ② The size of the tolerance reduces the permissible wave movement, see data sheet
- ③ Threaded holes in accordance with DIN 13 with recesses in accordance with DIN 76 min. 1.05 x thread diameter

Anschlussbelegung Supply/Communication pin assignment

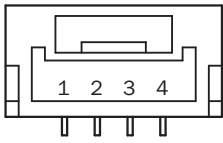

integrated in motor cable = J, K

PIN	Signal	Explanation
1	-	Not connected - no function
2	+U <sub>S</sub> /DSL+	Supply 7 V ... 12 V
3	GND/DSL-	Ground connection
4	-	Not connected - no function

Recommended outer diameter of set of stranded wires: 4 mm +0/-0.3 mm  
 Recommended mating connector: JST (GHR-04V-S)

Diagrams

Position noise ["]

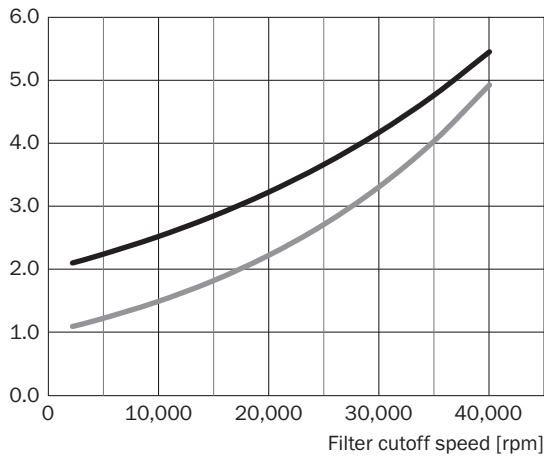

- 18 Bit
- 20 Bit

Signal noise is measured as 1 standard deviation ( $\sigma$ ) of the value distribution. Position filter cutoff speed is set by ressource 10Ah, see page 11.

### Diagrams

Typ. current consumption [A]

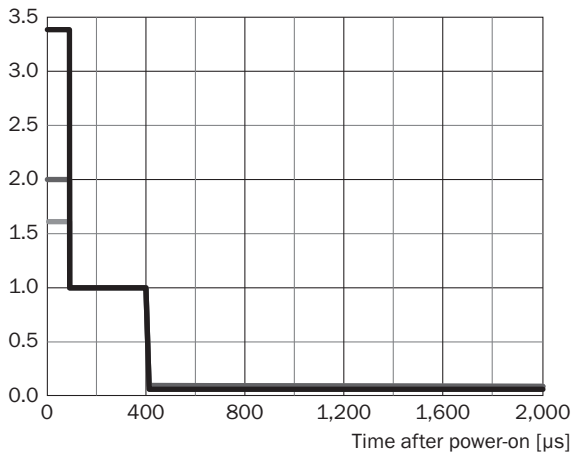

- 7 V
- 8 V
- 12 V



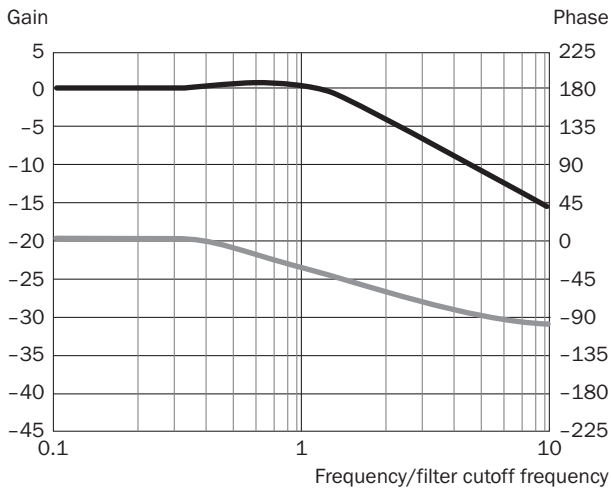

### Diagrams



- Gain [dB]
- Phase [°]

## Recommended accessories

Other models and accessories → [www.sick.com/EKS\\_EKM36](http://www.sick.com/EKS_EKM36)

	Brief description	Type	part no.
Mounting systems			
	<ul style="list-style-type: none"> <li><b>Description:</b> Mounting tools</li> <li><b>Suitable for:</b> Anschlussart T,J,K</li> </ul>	BEF-MW-EKX36	2060224
connectors and cables			
	<ul style="list-style-type: none"> <li><b>Description:</b> HIPERFACE DSL<sup>®</sup>, twisted, unshielded</li> <li><b>Connection type head A:</b> Female connector, stranded wire, 2-pin, straight</li> <li><b>Connection type head B:</b> Flying leads</li> <li><b>Signal type:</b> HIPERFACE DSL<sup>®</sup></li> <li><b>Cable:</b> 0.2 m, 2-wire</li> </ul>	DOL-0B02-G0M2XC1	2062083
	<ul style="list-style-type: none"> <li><b>Description:</b> HIPERFACE DSL<sup>®</sup>, twisted, unshielded</li> <li><b>Connection type head A:</b> Female connector, stranded wire, 2-pin, straight</li> <li><b>Connection type head B:</b> Flying leads</li> <li><b>Signal type:</b> HIPERFACE DSL<sup>®</sup></li> <li><b>Cable:</b> 0.4 m, 2-wire</li> </ul>	DOL-0B02-G0M4XC1	2086286
	<ul style="list-style-type: none"> <li><b>Description:</b> HIPERFACE DSL<sup>®</sup>, shielded</li> <li><b>Connection type head A:</b> Female connector, stranded wire, 4-pin, straight</li> <li><b>Connection type head B:</b> Flying leads</li> <li><b>Signal type:</b> HIPERFACE DSL<sup>®</sup></li> <li><b>Cable:</b> 0.43 m, 2-wire</li> <li><b>Note:</b> Non-isolated drain wire</li> </ul>	DOL-0B03-G0M4XC1	2087314
	<ul style="list-style-type: none"> <li><b>Description:</b> HIPERFACE DSL<sup>®</sup>, twisted, unshielded</li> <li><b>Connection type head A:</b> Female connector, stranded wire, 2-pin, straight</li> <li><b>Connection type head B:</b> Flying leads</li> <li><b>Signal type:</b> HIPERFACE DSL<sup>®</sup></li> <li><b>Cable:</b> 0.3 m, 2-wire</li> </ul>	DOL-0B02-G0M3XC1	2091818
	<ul style="list-style-type: none"> <li><b>Description:</b> HIPERFACE DSL<sup>®</sup>, twisted, shielded</li> <li><b>Connection type head A:</b> Female connector, stranded wire, 4-pin, straight</li> <li><b>Connection type head B:</b> Flying leads</li> <li><b>Signal type:</b> HIPERFACE DSL<sup>®</sup></li> <li><b>Cable:</b> 0.36 m, 2-wire</li> </ul>	DOL-0B02-G0M3AC2	2108944

## SICK AT A GLANCE

SICK is one of the leading manufacturers of intelligent sensors and sensor solutions for industrial applications. A unique range of products and services creates the perfect basis for controlling processes securely and efficiently, protecting individuals from accidents and preventing damage to the environment.

We have extensive experience in a wide range of industries and understand their processes and requirements. With intelligent sensors, we can deliver exactly what our customers need. In application centers in Europe, Asia and North America, system solutions are tested and optimized in accordance with customer specifications. All this makes us a reliable supplier and development partner.

Comprehensive services complete our offering: SICK LifeTime Services provide support throughout the machine life cycle and ensure safety and productivity.

For us, that is “Sensor Intelligence.”

## WORLDWIDE PRESENCE:

Contacts and other locations –[www.sick.com](http://www.sick.com)