

Article No. : 1FT2205-2AF12-1MB0



Figure similar

Client order no. :  
Order no. :  
Offer no. :  
Remarks :

Item no. :  
Consignment no. :  
Project :

### Basic motor data

Motor type	Permanent-magnet synchronous motor, Natural cooling, IP67
Motor type	Compact
Static torque	3.60 Nm
Static current	2.9 A
Maximum torque	10.80 Nm
Maximum current	9.5 A
Maximum speed	6,500 rpm
Rotor moment of inertia	4.0500 kgcm <sup>2</sup>
Weight	4.8 kg

### Rated data

SINAMICS S120, BLM/SLM 3AC 400V

Rated speed	3,000 rpm
Rated torque	3.00 Nm
Rated current	2.5 A
Rated power	0.94 kW

### Encoder system

Encoder system	Encoder AM22DQC: Absolute encoder 22 bit + 12 bit multiturn
Safety Integrated - Suitable encoder	Yes

### Motor connection

Connection type	Double cable connection for S120
Connector size power connector	M17
Connector size signal connector	M17

### Mechanical data

Design acc. to Code I	IM B5 (IM V1, IM V3)
Vibration severity grade	Grade A
Shaft height	48
Flange size (AB)	95 mm
Centering ring (N)	80 mm
Hole circle (M)	100 mm
Screw-on hole (S)	6.5 mm
Overall length (LB)	188 mm
Diameter of shaft (D)	19 mm
Length of shaft (E)	40 mm
Length of flange diagonal (P)	120 mm
Shaft end	Fitted key
Color of the housing	Standard (Anthracite, similar to RAL 7016)

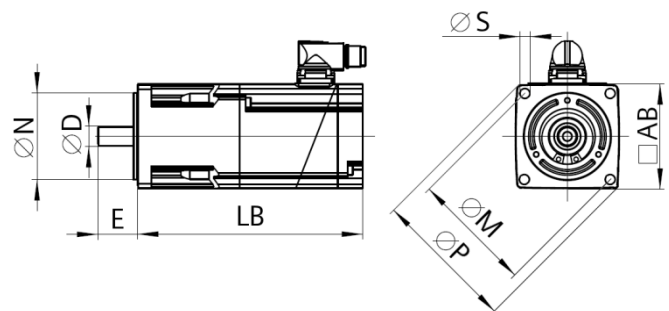

### Holding brake

Holding torque	8.00 Nm
Average dynamic torque	5.00 Nm
Opening time	90 ms
Closing time	25 ms
Maximum single switching energy <sup>1)</sup>	570 J
Service life, operating energy	284,000 J
Rated current <sup>2)</sup>	0.6 A

<sup>1)</sup>Up to three consecutive emergency stops and up to 25% of all emergency stops as a W<sub>max</sub> high energy stop possible.

<sup>2)</sup>Typical value for 20°C ambient temperature. At -15°C the break-induced currents can be increased by up to 30%.