

PNI021

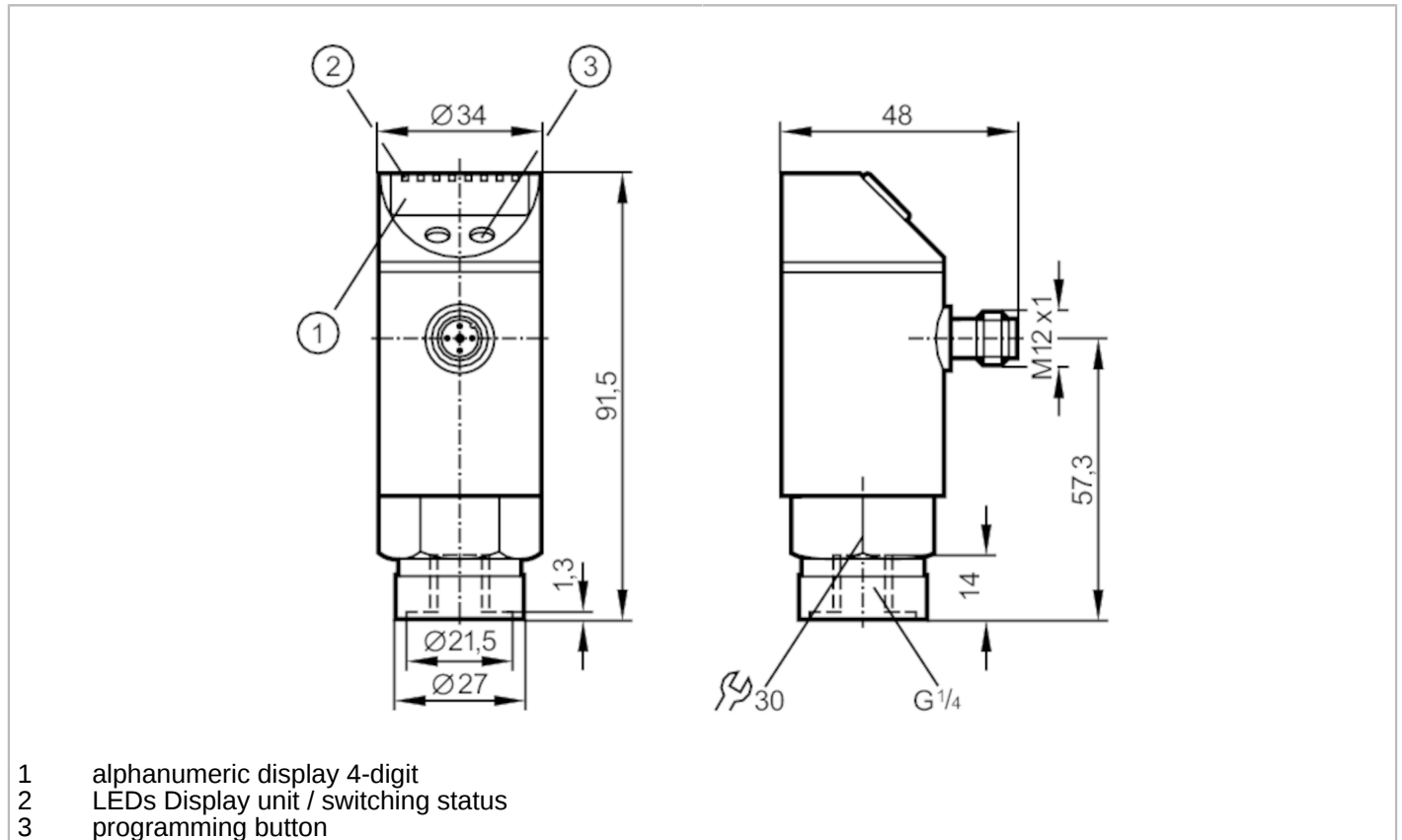

Pressure sensor with analogue input

PNI250-SBR14-QFRKG/US/ V



Application	
Media	liquids and gases
Conditionally suitable for	use in gases at pressures > 25 bar only on request
Medium temperature [°C]	-25...80
Pressure rating [bar]	400
Min. bursting pressure [bar]	850
Type of pressure	relative pressure
Electrical data	
Operating voltage [V]	18...30 DC
Current consumption [mA]	< 90
Min. insulation resistance [MΩ]	100; (500 V DC)
Protection class	III
Reverse polarity protection	yes
Power-on delay time [s]	0.2
Integrated watchdog	yes
Inputs / outputs	
Number of inputs and outputs	Number of digital outputs: 2

PNI021



Pressure sensor with analogue input

PNI250-SBR14-QFRKG/US/ V

Inputs		
Analogue input (current)	[mA]	0...20
Max. load	[Ω]	300
Analogue input (voltage)	[V]	0...10
Min. load resistance	[Ω]	90000
Outputs		
Total number of outputs		2
Output signal		switching signal
Electrical design		PNP/NPN
Number of digital outputs		2
Output function		normally open / normally closed; (parameterisable)
Max. voltage drop switching output DC	[V]	2
Permanent current rating of switching output DC	[mA]	250
Switching frequency DC	[Hz]	< 170
Short-circuit protection		yes
Type of short-circuit protection		pulsed
Overload protection		yes
Measuring/setting range		
Measuring range	[bar]	0...250
Set point SP	[bar]	-62...250
Note on setpoint SP		differential pressure
Reset point rP	[bar]	-63...249
Note on setpoint SP		differential pressure
In steps of	[bar]	1
Accuracy / deviations		
Characteristics deviation [% of the final value]		< ± 0,6
Temperature drift per 10 K		< ± 0,3
Temperature drift per 10 K		< ± 0,3
Characteristics deviation analogue input		< ± 0,3
Temperature drift analogue input per 10 K		< ± 0,1
Temperature drift analogue input	[°C]	0...80
Response times		
Response time	[ms]	< 3
Delay time programmable dS, dr	[s]	0, 0,1...50
Damping for the switching output dAP	[s]	0...4

PNI021



Pressure sensor with analogue input

PNI250-SBR14-QFRKG/US/ V

Software / programming		
Adjustment of the switch point	programming button	
Parameter setting options	hysteresis / window; normally open / normally closed; switching logic; current/voltage input; Damping; adaptation of displayed values; display can be rotated and switched off; Display unit	
Operating conditions		
Ambient temperature [°C]	-25...80	
Storage temperature [°C]	-40...100	
Protection	IP 67	
Tests / approvals		
EMC	EN 61000-4-2 ESD	4 kV CD / 8 kV AD
	EN 61000-4-3 HF radiated	10 V/m
	EN 61000-4-4 Burst	2 kV
	EN 61000-4-6 HF conducted	10 V
Shock resistance	DIN IEC 68-2-27	50 g (11 ms)
Vibration resistance	DIN IEC 68-2-6	20 g (10...2000 Hz)
MTTF [years]	152	
Mechanical data		
Weight [g]	292.6	
Materials	stainless steel (1.4305 / 303); PBT; PC; PA; FKM	
Materials (wetted parts)	stainless steel (1.4305 / 303); ceramics; FKM	
Min. pressure cycles	100 million	
Process connection	threaded connection G 1/4 internal thread	
Displays / operating elements		
Display	Display unit	3 x LED, green
	display mode	3 x LED, green
	function display	alphanumeric display, 4-digit
	measured values	alphanumeric display, 4-digit
Display unit	bar; psi; MPa	
Remarks		
Pack quantity	1 pcs.	
Electrical connection		
Connector: 1 x M12; Contacts: gold-plated		
		

PNI021



Pressure sensor with analogue input

PNI250-SBR14-QFRKG/US/ V

Connection

