

E35060

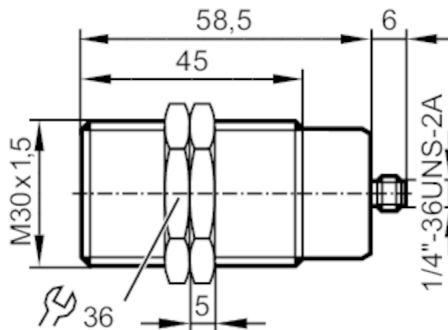

Measuring head for infrared temperature sensors

SENSOR HEAD



1 3/4" Clamp ISO 2852

Operating conditions

Ambient temperature [°C] -20...250

Mechanical data

Weight [g] 165.2

Materials AIMg3 black anodised; stainless steel (1.4305 / 303);
lock nuts: stainless steel (1.4301 / 304); O-ring: FKM

Lens material tempered optical glass

Tightening torque [Nm] 0.165

Remarks

Pack quantity 1 pcs.

Diagrams and graphs

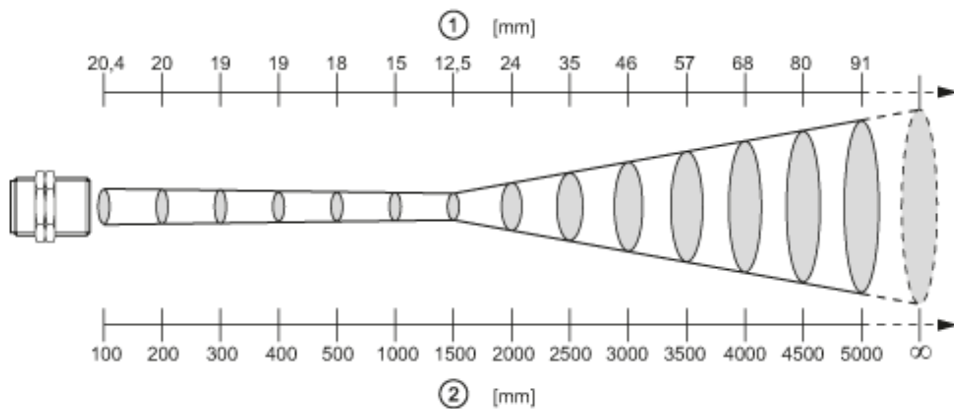

1 diameter of the measured spot

2 measuring distance