

PN2597

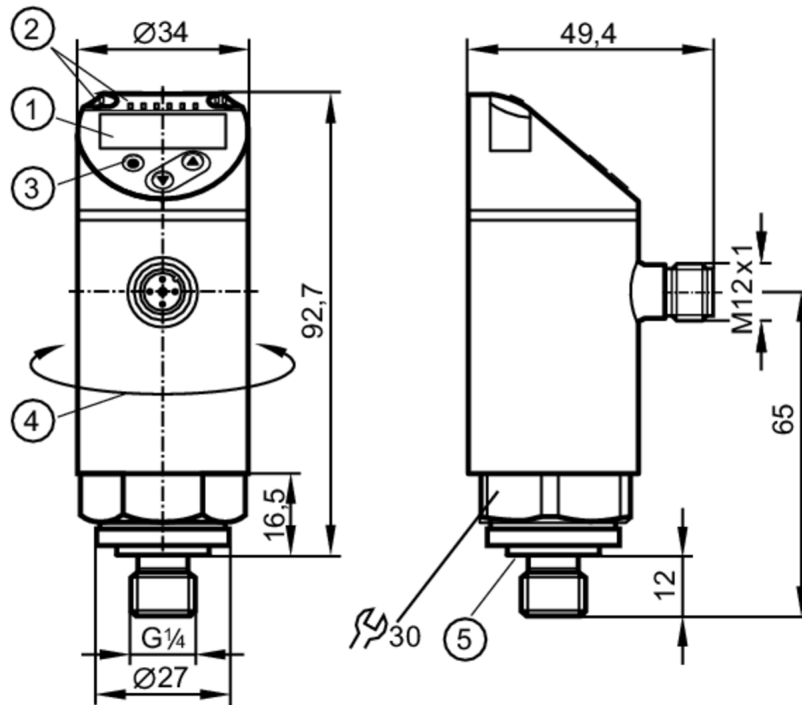

Pressure sensor with display

PN-001BREG14-MFRKG/US/ IV



- 1 alphanumeric display 4-digit red/green
- 2 LEDs Display unit / switching status
- 3 programming button
- 4 upper part of the housing can be rotated 345°
- 5 Sealing



Application

Measuring element	ceramic-capacitive pressure measuring cell		
Application	for industrial applications		
Media	liquids and gases		
Medium temperature [°C]	-25...80		
Pressure rating	10000 mbar	145 psi	1000 kPa
Min. bursting pressure	30000 mbar	450 psi	3000 kPa
Vacuum resistance [mbar]	-1000		
Type of pressure	relative pressure		

Electrical data

Operating voltage [V]	18...30 DC; (according to EN 50178 SELV/PELV)		
Current consumption [mA]	< 35		
Min. insulation resistance [MΩ]	100; (500 V DC)		
Protection class	III		
Reverse polarity protection	yes		
Power-on delay time [s]	0.3		
Integrated watchdog	yes		



Pressure sensor with display

PN-001BREG14-MFRKG/US/ IV

Outputs			
Total number of outputs		2	
Output signal		switching signal; analogue signal; IO-Link; (configurable)	
Electrical design		PNP/NPN	
Number of digital outputs		2	
Output function		normally open / normally closed; (parameterisable)	
Max. voltage drop switching output DC	[V]	2	
Permanent current rating of switching output DC	[mA]	250	
Switching frequency DC	[Hz]	< 500	
Number of analogue outputs		1	
Analogue current output	[mA]	4...20; (scalable 1:5)	
Max. load	[Ω]	500	
Analogue voltage output	[V]	0...10; (scalable 1:5)	
Min. load resistance	[Ω]	2000	
Short-circuit protection		yes	
Type of short-circuit protection		pulsed	
Overload protection		yes	
Measuring/setting range			
Measuring range		-50...1000 mbar	-0.72...14.5 psi
			-5...100 kPa
Set point SP		-44...1000 mbar	-0.64...14.5 psi
			-4.4...100 kPa
Reset point rP		-48...996 mbar	-0.7...14.44 psi
			-4.8...99.6 kPa
Analogue start point		-50...800 mbar	-0.72...11.6 psi
			-5...80 kPa
Analogue end point		150...1000 mbar	2.18...14.5 psi
			15...100 kPa
In steps of		2 mbar	0.02 psi
			0.2 kPa
Accuracy / deviations			
Switch point accuracy	[% of the span]	< ± 0,4; (Turn down 1:1)	
Repeatability	[% of the span]	< ± 0,1; (with temperature fluctuations < 10 K; Turn down 1:1)	
Characteristics deviation	[% of the span]	< ± 0,25 (BFSL) / < ± 0,5 (LS); (Turn down 1:1; BFSL = Best Fit Straight Line; LS = limit value setting)	
Hysteresis deviation	[% of the span]	< ± 0,1; (Turn down 1:1)	
Long-term stability	[% of the span]	< ± 0,05; (Turn down 1:1; per 6 months)	
Temperature coefficient zero point	[% of the span / 10 K]	0,2; (-25...80 °C)	
Temperature coefficient span	[% of the span / 10 K]	0,2; (-25...80 °C)	

PN2597



Pressure sensor with display

PN-001BREG14-MFRKG/US/ IV

Response times		
Response time	[ms]	< 1.5
Delay time programmable dS, dr	[s]	0...50
Damping for the switching output dAP	[s]	0...4
Damping for the analogue output dAA	[s]	0...4
Max. response time analogue output	[ms]	3
Software / programming		
Parameter setting options	hysteresis / window; normally open / normally closed; switch-on/ switch-off delay; Damping; Display unit; current/voltage output	
Interfaces		
Communication interface	IO-Link	
Transmission type	COM2	
IO-Link revision	1.1	
SDCI standard	IEC 61131-9	
IO-Link device ID	465 d / 00 01 d1 h	
Profiles	Smart Sensor: Process Data Variable; Device Identification, Device Diagnosis	
SIO mode	yes	
Required master port type	A	
Process data analogue	1	
Process data binary	2	
Min. process cycle time	[ms]	2.3
Operating conditions		
Ambient temperature	[°C]	-25...80
Storage temperature	[°C]	-40...100
Protection	IP 65; IP 67	
Tests / approvals		
EMC	DIN EN 61000-6-2	
	DIN EN 61000-6-3	
Shock resistance	DIN EN 60068-2-27	50 g (11 ms)
Vibration resistance	DIN EN 60068-2-6	20 g (10...2000 Hz)
MTTF	[years]	138
UL approval	UL Approval no.	J012
Pressure Equipment Directive	Sound Engineering Practice; can be used for group 2 fluids; group 1 fluids on request	

PN2597



Pressure sensor with display

PN-001BREG14-MFRKG/US/ IV

Mechanical data	
Weight [g]	263.2
Materials	stainless steel (1.4404 / 316L); PBT+PC-GF30; PBT-GF20; PC
Materials (wetted parts)	stainless steel (1.4404 / 316L); Al2O3 (96 %; ceramics); FKM
Min. pressure cycles	100 million
Tightening torque [Nm]	25...35; (recommended tightening torque; depends on lubrication, seal and pressure rating)
Process connection	threaded connection G 1/4 external thread (DIN EN ISO 1179-2); internal thread M5
Process connection sealing	FKM (to DIN 3869)
Restrictor element integrated	no (can be retrofitted)

Displays / operating elements		
Display	Display unit	3 x LED, green (bar, psi, MPa)
	switching status	2 x LED, yellow
	measured values	alphanumeric display, red/green 4-digit

Remarks	
Pack quantity	1 pcs.

Electrical connection

Connector: 1 x M12; Contacts: gold-plated



PN2597



Pressure sensor with display

PN-001BREG14-MFRKG/US/ IV

Connection

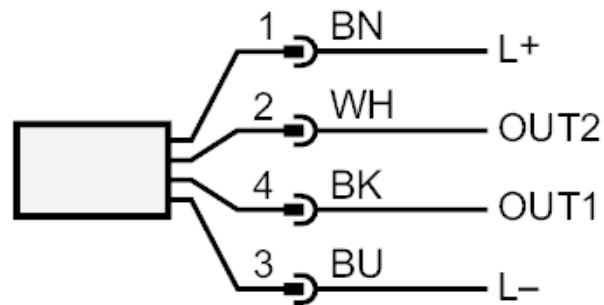

OUT1 switching output

OUT2 switching output

analogue output

Core colours :

BK = black

BN = brown

BU = blue

WH = white