

LR8300

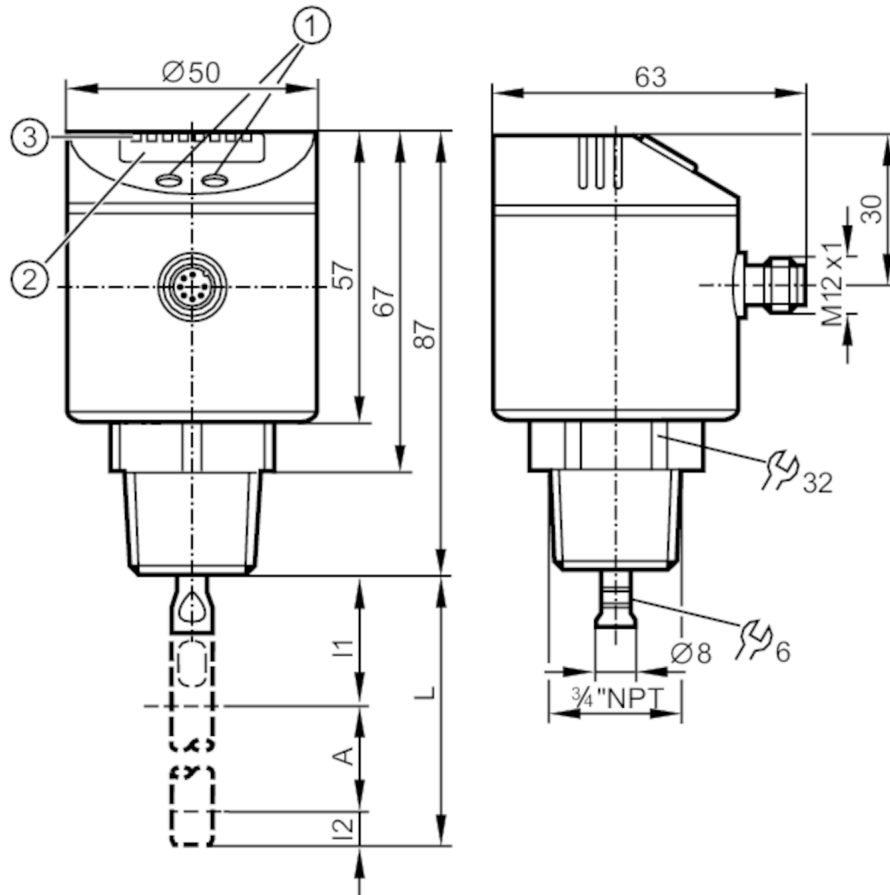

Continuous level sensor (guided wave radar)

LR0000B-BN34ASPKG/US



- 1 alphanumeric display 4-digit
- 2 LEDs Display unit / switching status
- 3 programming buttons
- A active range
- I1 / I2 inactive ranges



Application

Media	hydrous coolants; water; media similar to water
Dielectric constant of the medium	≥ 20
Cannot be used for	oils; greases; granulates; bulk material; acids; alkali; heavily foaming media
Medium temperature [°C]	0...80; (90 < 1 h)
Tank pressure [bar]	-1...16
MAWP (for applications according to CRN) [bar]	25

LR8300



Continuous level sensor (guided wave radar)

LR0000B-BN34ASPKG/US

Electrical data		
Operating voltage	[V]	18...30 DC
Current consumption	[mA]	< 80
Protection class		III
Reverse polarity protection		yes
Power-on delay time	[s]	< 3
Inputs / outputs		
Number of inputs and outputs		Number of digital outputs: 4
Outputs		
Total number of outputs		4
Output signal		switching signal; IO-Link
Electrical design		PNP
Number of digital outputs		4
Output function		normally open / normally closed; (parameterisable)
Max. voltage drop switching output DC	[V]	2.5
Permanent current rating of switching output DC	[mA]	200
Short-circuit protection		yes
Type of short-circuit protection		thermal, pulsed
Measuring/setting range		
Probe length L	[mm]	100...1600
Active range A	[mm]	L-40
Inactive range I1 / I2	[mm]	30 / 10
Setting range		
Set point SP	[mm]	$\geq 15 / \leq L-30$
Reset point rP	[mm]	$\geq 10 / \leq L-35$
In steps of	[mm]	5
Hysteresis	[mm]	> 5
Accuracy / deviations		
Repeatability	[mm]	± 5
Switch point accuracy	[mm]	$\pm (15 + 0,5 \%)$; (% of the final value of the measuring range: L - 30 mm)

LR8300



Continuous level sensor (guided wave radar)

LR0000B-BN34ASPKG/US

Interfaces		
Communication interface	IO-Link	
Transmission type	COM2 (38,4 kBaud)	
IO-Link revision	1.1	
SDCI standard	IEC 61131-9 CDV	
IO-Link device ID	011 d / 00 00 B h	
Profiles	no profile	
SIO mode	yes	
Required master port type	A	
Process data analogue	1	
Process data binary	4	
Min. process cycle time [ms]	2.3	
Operating conditions		
Ambient temperature [°C]	0...60	
Storage temperature [°C]	-25...80	
Protection	IP 67	
Tests / approvals		
EMC	IEC 60947-1	
Shock resistance	DIN IEC 68-2-27	50 g (11 ms)
Vibration resistance	DIN IEC 68-2-6	5 g (10...2000 Hz)
MTTF [years]	182.01	
Mechanical data		
Weight [g]	332.2	
Materials	stainless steel (1.4301 / 304); FKM; PBT; PC; PEI; TPE-V; PTFE	
Materials (wetted parts)	stainless steel (1.4305 / 303); probe connection: stainless steel (1.4435 / 316L); PTFE; FKM	
Process connection	3/4" NPT	
Displays / operating elements		
Display	Display unit	3 x LED, green
	switching status	4 x LED, yellow
	level	alphanumeric display, 4-digit
	parameter setting	alphanumeric display, 4-digit
Accessories		
Accessories (optional)	Probe:, E43203...E43205 / E43207...E43210	
Remarks		
Notes	For 8-pole sockets the core colours are not standardised.; Please note the wiring of the sensor and the sockets (see data sheet).	
Pack quantity	1 pcs.	
Electrical connection		
Connector: 1 x M12; Contacts: gold-plated		

LR8300



Continuous level sensor (guided wave radar)

LR0000B-BN34ASPKG/US

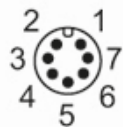

Connection

