

O5P202

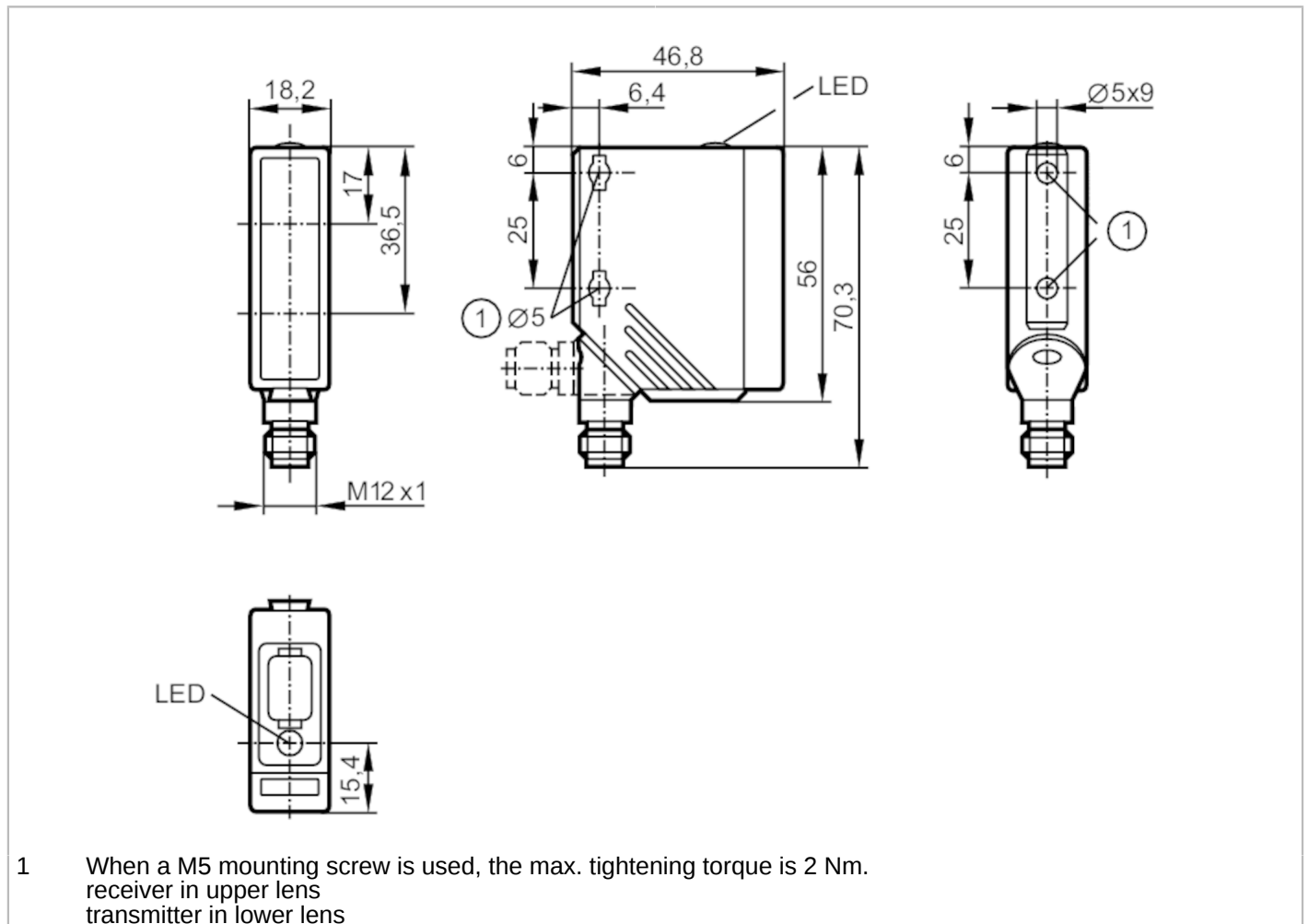

Retro-reflective sensor

O5P-CPKG/US100



Application	
Function principle	Retro-reflective sensor
Electrical data	
Operating voltage [V]	10...36 DC
Current consumption [mA]	20
Protection class	II
Reverse polarity protection	yes
Type of light	red light
Wave length [nm]	624

O5P202



Retro-reflective sensor

O5P-CPKG/US100

Outputs		
Electrical design		PNP
Output function		complementary
Max. voltage drop switching output DC	[V]	2.5
Permanent current rating of switching output DC	[mA]	200
Switching frequency DC	[Hz]	1000
Short-circuit protection		yes
Type of short-circuit protection		pulsed
Overload protection		yes
Detection zone		
Range referred to prismatic reflector	[m]	0.1...7; (Prismatic reflector Ø 80 E20005)
Range adjustable		no
Max. light spot diameter	[mm]	175
Light spot dimensions refer to		at maximum range
Polarisation filter available		yes
Operating conditions		
Ambient temperature	[°C]	-25...60
Protection		IP 67
Tests / approvals		
EMC		EN 60947-5-2
MTTF	[years]	456
Mechanical data		
Weight	[g]	62.2
Housing		rectangular
Dimensions	[mm]	56 x 18.2 x 46.8
Materials		housing: PA; bezel: stainless steel; operator interface: TPE
Lens material		PMMA
Lens alignment		side lens
Displays / operating elements		
Display	switching status	1 x LED, yellow
Remarks		
Pack quantity		1 pcs.
Electrical connection		
Connector: 1 x M12		
		

Retro-reflective sensor

O5P-CPKG/US100

Connection

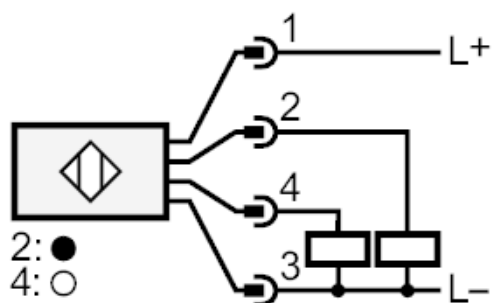

Diagrams and graphs

excess gain graph

