

SBG434

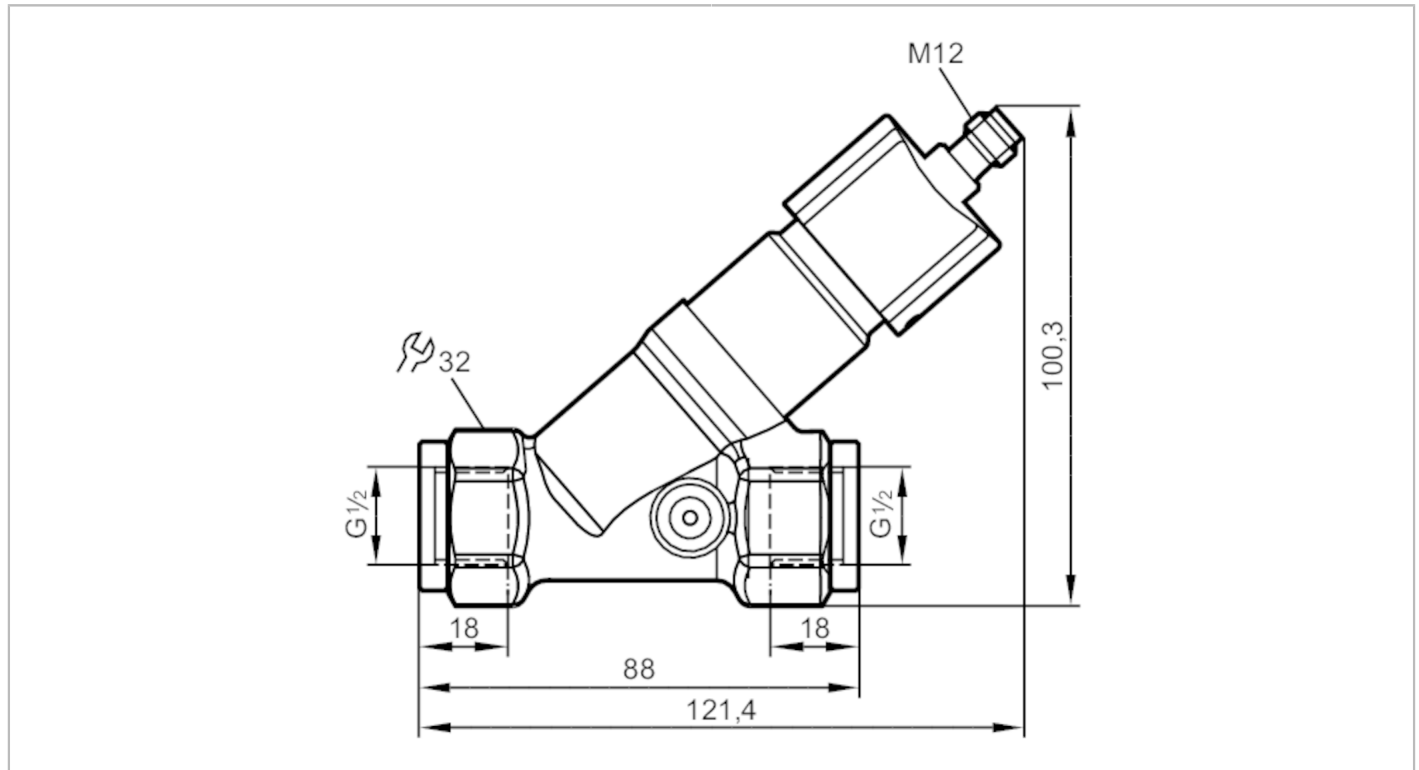

Flow transmitter with integrated backflow prevention

SBG12HF010KG/US



Application	
Media	Liquids; water; glycol solutions; oils; coolants
Medium temperature [°C]	-10...100
Pressure rating [bar]	40
Electrical data	
Operating voltage [V]	18...32 DC; (to SELV/PELV)
Current consumption [mA]	< 35
Protection class	III
Reverse polarity protection	yes
Outputs	
Output signal	analogue signal
Analogue current output [mA]	4...20
Max. load [Ω]	500
Short-circuit protection	yes
Overload protection	yes
Measuring/setting range	
Measuring range [l/min]	2...50
Accuracy / deviations	
Repeatability [% of the final value]	1
Measuring error [% of the final value]	± 5

SBG434



Flow transmitter with integrated backflow prevention

SBG12HF010KG/US

Response times		
Response time	[s]	< 0.01
Operating conditions		
Ambient temperature	[°C]	0...60
Storage temperature	[°C]	-15...80
Protection		IP 65; IP 67
Tests / approvals		
EMC	DIN EN 61000-6-2	
	DIN EN 61000-6-3	
Shock resistance	DIN EN 60068-2-27	20 g (11 ms)
Vibration resistance	DIN EN 60068-2-6	5 g (10...2000 Hz)
Mechanical data		
Weight	[g]	554.2
Materials	brass chemically nickel-plated; PP; stainless steel (1.4404 / 316L); aluminium anodised; PA	
Materials (wetted parts)	stainless steel (1.4401 / 316); brass; brass chemically nickel-plated; PP; PPS; O-ring: FKM	
Process connection	G 1/2	
Switching cycles mechanical	10 million	
Remarks		
Remarks	Recommendation Use 200 micron filtration All data refer to water (20 °C).	
Pack quantity	1 pcs.	

Electrical connection

Connector: 1 x M12



SBG434



Flow transmitter with integrated backflow prevention

SBG12HF010KG/US

Connection

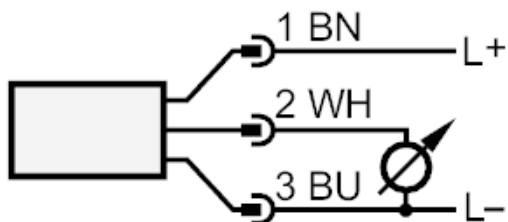

colours to DIN EN 60947-5-2

Core colours :

BN = brown
BU = blue
WH = white

Diagrams and graphs

Pressure loss

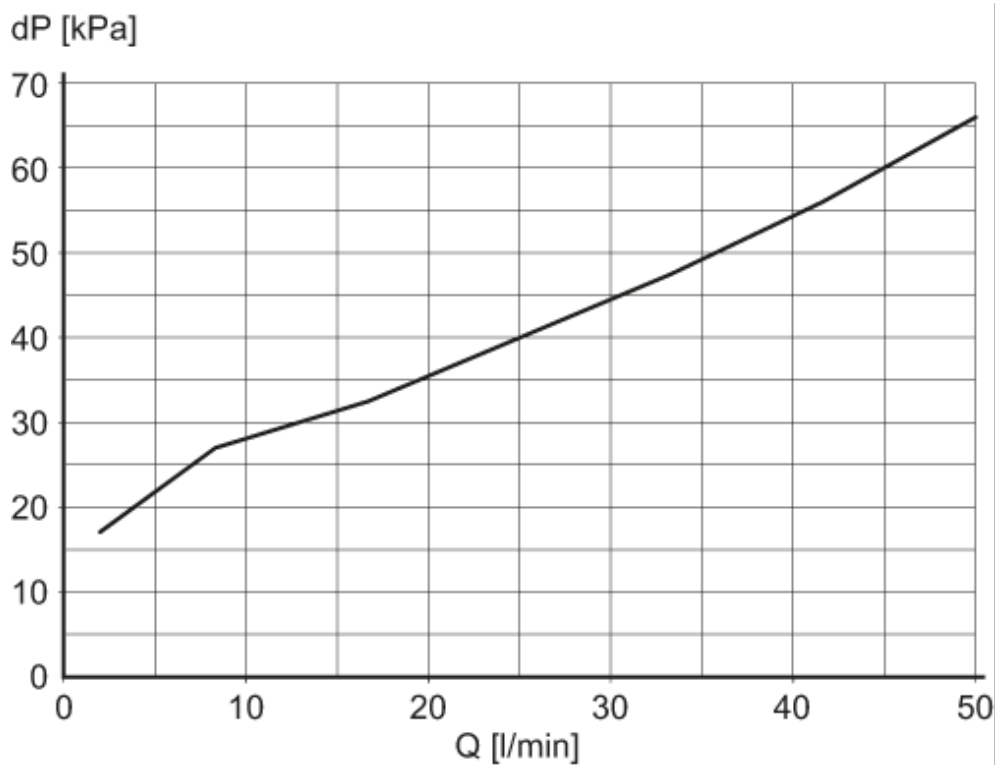

dP Pressure loss

Q volumetric flow quantity