

EVF530

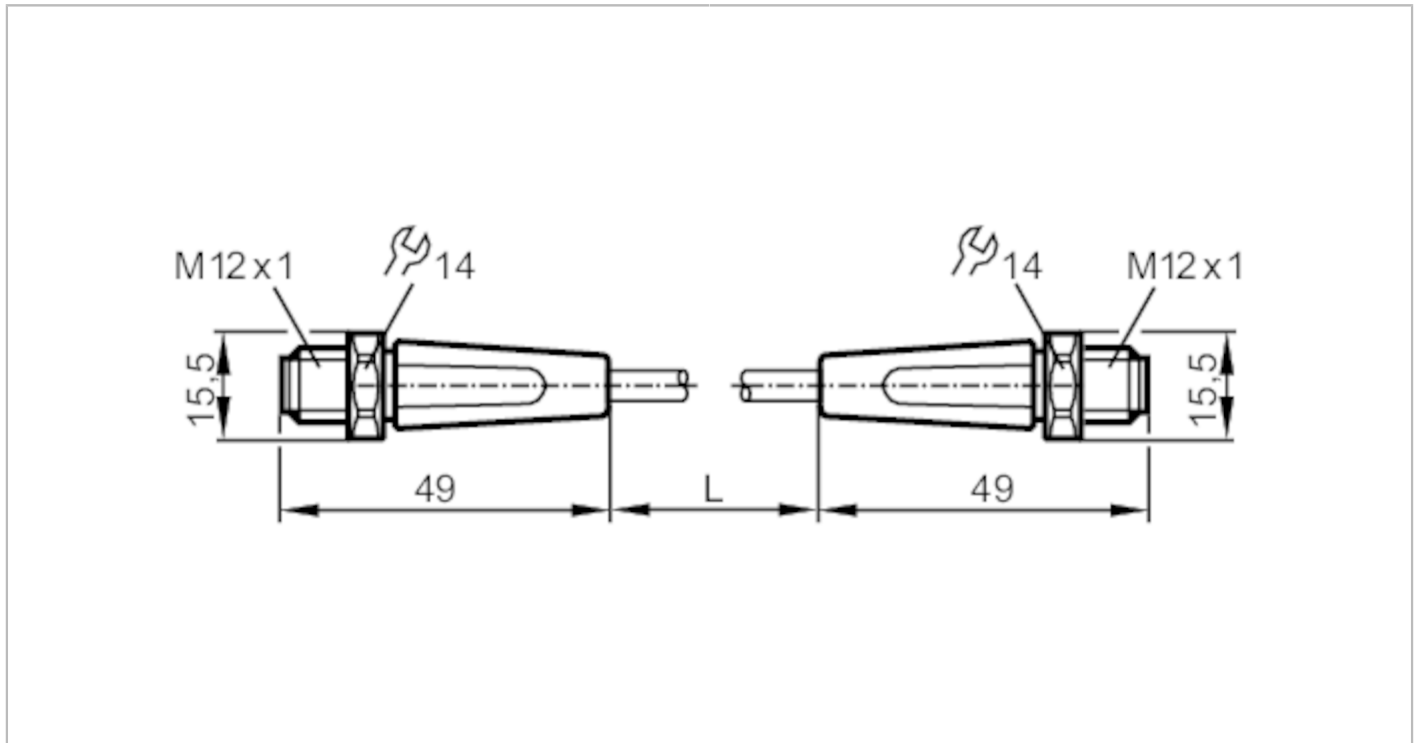

Connection cable

VSTGN040VAS0001P04STGN040VAS



Application		
Application	Industrial Ethernet; CAT5/CAT5e; 100 Mbit/s; hygienic and wet areas in the food industry	
Free from silicone	yes	
Electrical data		
Operating voltage [V]	< 50 AC / < 60 DC	
Protection class	III	
Max. current load total [A]	4	
Operating conditions		
Ambient temperature [°C]	-25...80	
Ambient temperature (moving) [°C]	0...80	
Protection	IP 65; IP 67; IP 68; IP 69K	
Mechanical data		
Weight [g]	92.2	
Dimensions [mm]	15.5 x 15.5 x 49	
Materials	PP Halogen-free	
Material nut	stainless steel (1.4404 / 316L)	
Drag chain suitability	bending radius for flexible use	min. 10 x cable diameter
	travel speed	max. 3.3 m/s for a horizontal travel length of 5 m and max. acceleration of 5 m/s ²
	bending cycles	> 1 Mio.
	torsional strain	± 180 °/m
Drag chain suitability	yes	

EVF530



Connection cable

VSTGN040VAS0001P04STGN040VAS

Remarks

Pack quantity

1 pcs.

Electrical connection

Cable: 1 m, MPPE, Halogen-free, grey, Ø 6.5 mm, shielded; 4 x 0.34 mm² (7 x Ø 0.25 mm)

Electrical connection - plug

Connector: 1 x M12, straight; Moulded body: PP, Halogen-free; Locking: stainless steel (1.4404 / 316L); Contacts: gold-plated;
Tightening torque: 0.6...1.2 Nm; Shielded connection cable: screen connected



Connection

