

SM6050

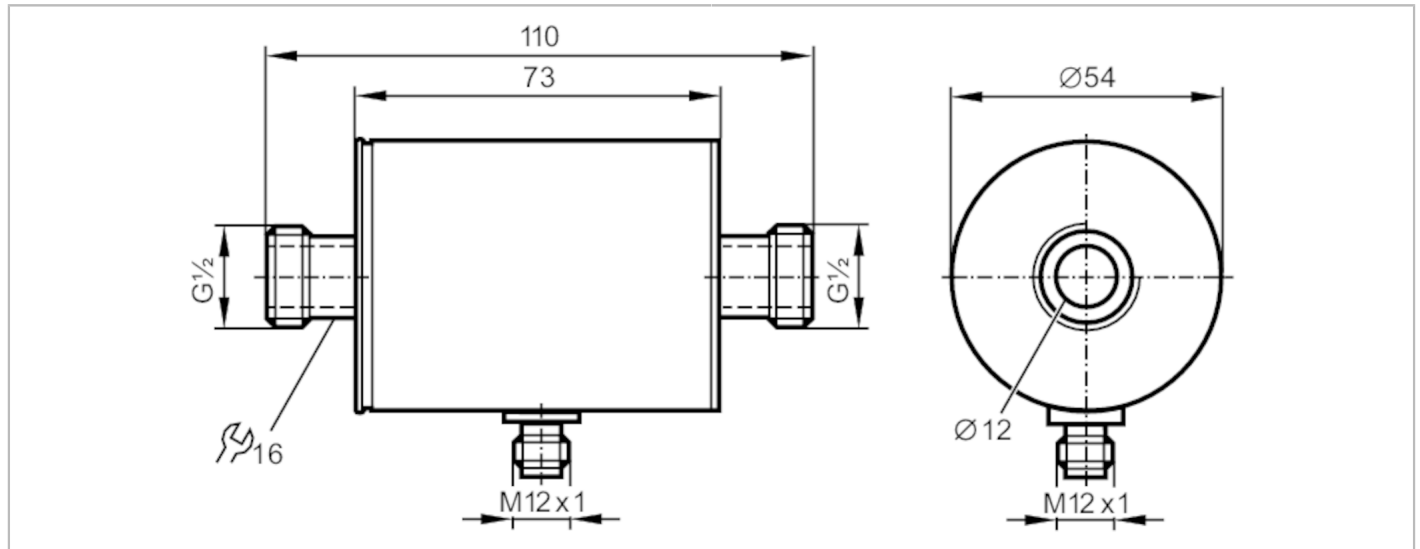

Magnetic-inductive flow meter

SMR12GGX10KG/US-100



Application	
Application	for industrial applications
Installation	connection to pipe by means of an adapter
Media	conductive liquids; water; hydrous media
Medien	conductivity: $\geq 20 \mu\text{S/cm}$ viscosity: $< 70 \text{ mm}^2/\text{s}$ (40 °C)
Medium temperature	[°C] -10...70
Pressure rating	[bar] 16
Electrical data	
Operating voltage	[V] 18...30 DC; (according to EN 50178 SELV/PELV)
Current consumption	[mA] 95; (24 V)
Min. insulation resistance	[MΩ] 100; (500 V DC)
Protection class	III
Reverse polarity protection	yes
Power-on delay time	[s] 5
Outputs	
Total number of outputs	1
Output signal	analogue signal; IO-Link; (configurable)
Permanent current rating of switching output DC	[mA] 250
Number of analogue outputs	1
Analogue current output	[mA] 4...20
Max. load	[Ω] 500
Overload protection	yes
Measuring/setting range	
Measuring range	[l/min] 0...25

SM6050



Magnetic-inductive flow meter

SMR12GGX1OKG/US-100

Accuracy / deviations		
Flow monitoring		
Accuracy (in the measuring range)		$\pm (0,8 \% MW + 0,5 \% MEW)$
Repeatability		$\pm 0,2\% MEW$
Response times		
Flow monitoring		
Response time	[s]	0.15
Temperature monitoring		
Dynamic response T05 / T09	[s]	T09 = 20 (Q > 1 l/min)
Interfaces		
Communication interface		IO-Link
Transmission type		COM2 (38,4 kBaud)
IO-Link revision		1.1
SDCI standard		IEC 61131-9
IO-Link device ID		571 / 00 02 3b h
Profiles		Smart Sensor: Process Data Variable; Device Identification, Device Diagnosis
SIO mode		yes
Required master port type		A
Process data analogue		2
Min. process cycle time	[ms]	3
Operating conditions		
Ambient temperature	[°C]	-10...60
Storage temperature	[°C]	-25...80
Protection		IP 67
Tests / approvals		
EMC		DIN EN 60947-5-9
Shock resistance		DIN IEC 68-2-27
Vibration resistance		DIN IEC 68-2-6
MTTF	[years]	167
Pressure Equipment Directive		Sound Engineering Practice; can be used for group 2 fluids; group 1 fluids on request
Mechanical data		
Weight	[g]	490.6
Materials		stainless steel (1.4404 / 316L); PBT-GF20; FKM; TPE
Materials (wetted parts)		stainless steel (1.4404 / 316L); PEEK; FKM
Process connection		threaded connection G 1/2 flat seal
Remarks		
Remarks		MW = measured value MEW = Final value of the measuring range
Pack quantity		1 pcs.
Electrical connection		

Connector: 1 x M12; Contacts: gold-plated

SM6050



Magnetic-inductive flow meter

SMR12GGX10KG/US-100



Connection

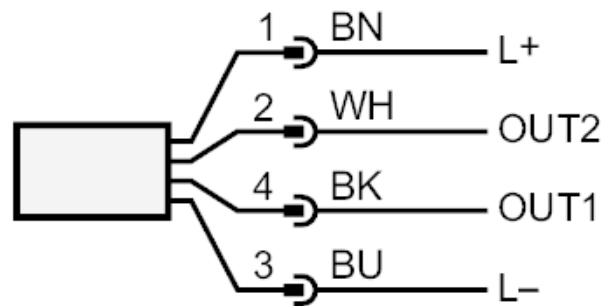

colours to DIN EN 60947-5-2

OUT1: IO-Link
OUT2: analogue output

Core colours :

BN = brown
WH = white
BK = black
BU = blue

SM6050



Magnetic-inductive flow meter

SMR12GGX10KG/US-100

Diagrams and graphs

Pressure loss

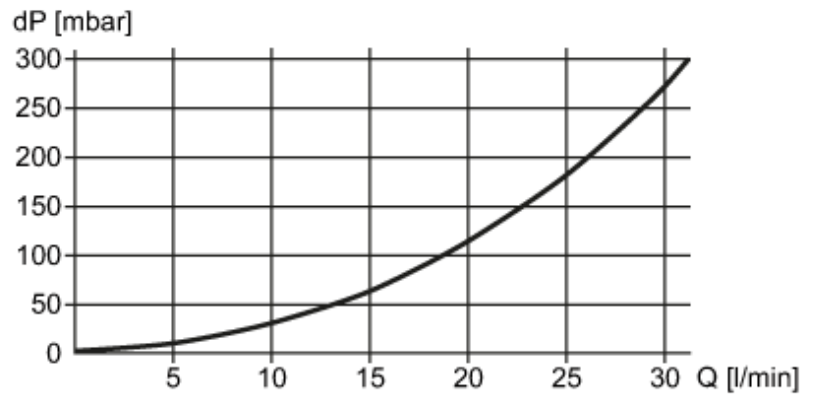

dP Pressure loss

Q volumetric flow quantity