

IFT208

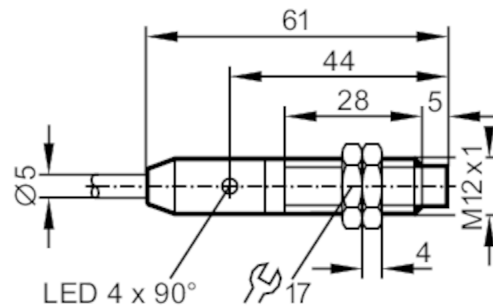

Inductive sensor

IFB3007-BPKG/M/V4A/6M/WH



Electrical data

Operating voltage	[V]	10...36 DC
Current consumption	[mA]	10; (24 V)
Protection class		II
Reverse polarity protection		yes

Outputs

Electrical design		PNP
Output function		normally open
Max. voltage drop switching output DC	[V]	2.5
Permanent current rating of switching output DC	[mA]	100
Switching frequency DC	[Hz]	800
Short-circuit protection		yes
Type of short-circuit protection		pulsed
Overload protection		yes

Detection zone

Sensing range	[mm]	7
Real sensing range Sr	[mm]	7 ± 10 %
Operating distance	[mm]	0...5.7
Increased sensing range		yes

Accuracy / deviations

Correction factor		steel: 1 / stainless steel: 0.7 / brass: 0.5 / aluminium: 0.4 / copper: 0.3
Hysteresis	[% of Sr]	1...20
Switch point drift	[% of Sr]	-10...10

Operating conditions

Ambient temperature	[°C]	0...100
Protection		IP 68; IP 69K; ("COP")

IFT208



Inductive sensor

IFB3007-BPKG/M/V4A/6M/WH

Tests / approvals		
EMC	EN 61000-4-2 ESD	4 kV CD / 8 kV AD
	EN 61000-4-3 HF radiated	10 V/m
	EN 61000-4-4 Burst	2 kV
	EN 61000-4-6 HF conducted	10 V
	EN 55011	class B
MTTF	[years]	2006
UL approval	Ta	0...40 °C
	Enclosure type	Type 1
	voltage supply	Limited Voltage/Current
	File number UL	E174191

Mechanical data		
Weight	[g]	247.8
Housing		threaded type
Mounting		non-flush mountable
Dimensions	[mm]	M12 x 1 / L = 61
Thread designation		M12 x 1
Materials		stainless steel (1.4404 / 316L); sensing face: PEEK

Displays / operating elements		
Display	switching status	4 x 90° LED, yellow

Accessories		
Accessories (supplied)		lock nuts: 2

Remarks		
Pack quantity		1 pcs.

Electrical connection		
Cable: 6 m, PVC; 3 x 0.34 mm ²		

Connection

