

# E20987

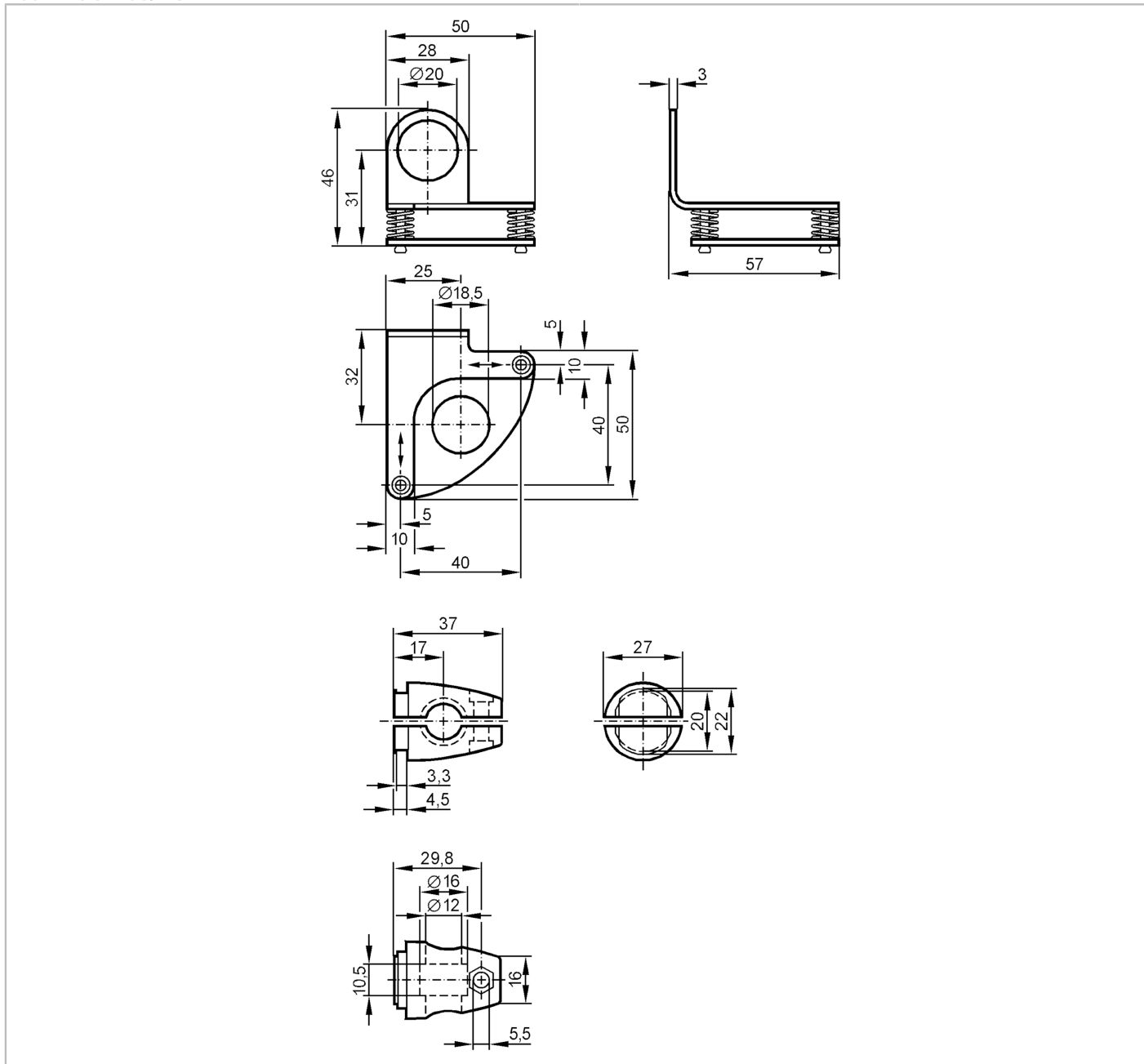

## Fixture for mounting and fine adjustment of laser sensors

MOUNTING SET OG/LASER



Application	
Design	clamp mounting
Mechanical data	
Weight [g]	232.4
Type of mounting	Mounting rod; (Ø 12 mm)
Materials	fixture: stainless steel (1.4571/316Ti); Clamp: diecast zinc
Alignment range	fine adjustment in 2 axes ± 3°
Accessories	
Accessories (supplied)	head cap screw: 1 x M10 x 55
Remarks	
Pack quantity	1 pcs.