

IN0117

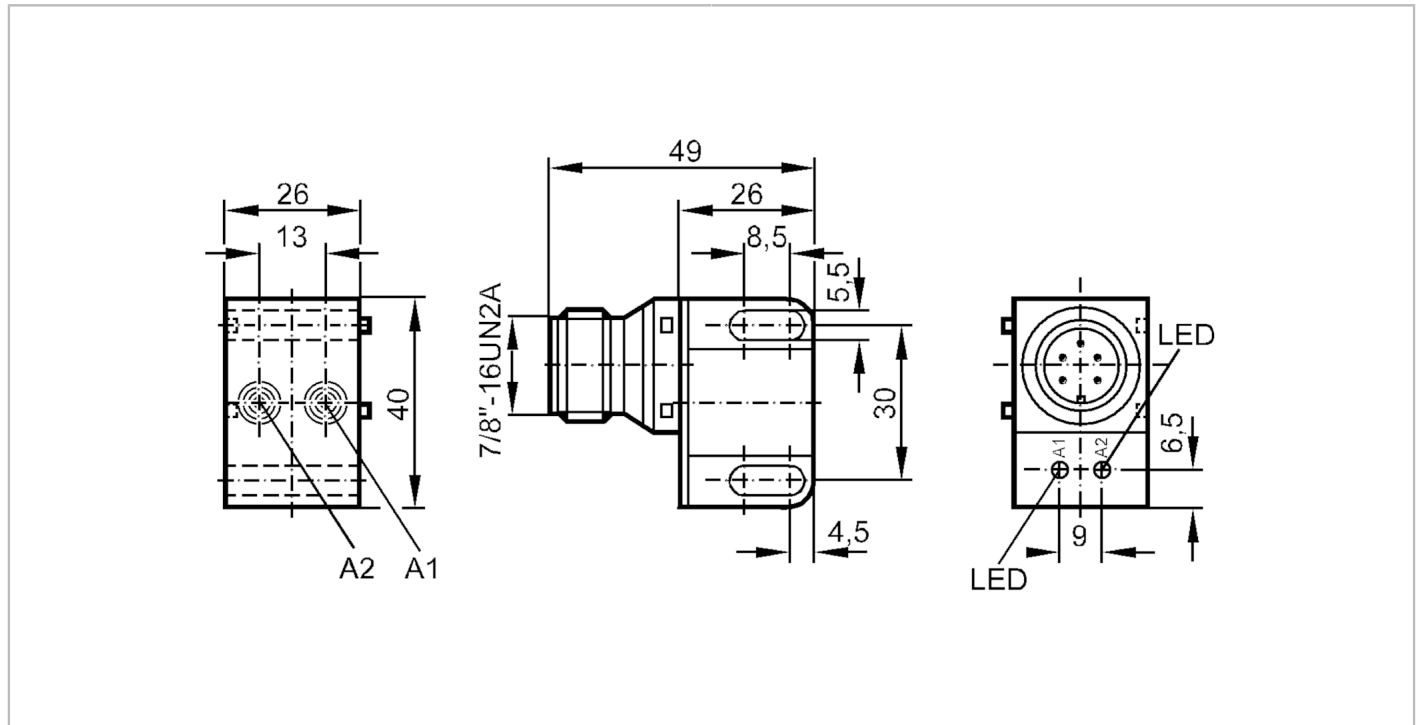

Inductive dual sensor for valve actuators

IND2004DAROA/SL/LS-500 RT



Electrical data

Frequency AC	[Hz]	47...63
Operating voltage	[V]	20...140 AC / 10...140 DC
Protection class		I
Reverse polarity protection		no

Outputs

Output function		2 x normally open
Max. voltage drop switching output DC	[V]	5
Max. voltage drop switching output AC	[V]	5
Minimum load current	[mA]	5
Max. leakage current	[mA]	0.8
Permanent current rating of switching output AC	[mA]	200
Permanent current rating of switching output DC	[mA]	200
Short-time current rating of switching output	[mA]	900; (20 ms / 0,5 Hz)
Switching frequency AC	[Hz]	25
Switching frequency DC	[Hz]	25
Short-circuit proof		no
Overload protection		no

IN0117



Inductive dual sensor for valve actuators

IND2004DAROA/SL/LS-500 RT

Detection zone		
Sensing range	[mm]	4
Real sensing range Sr	[mm]	4 ± 10 %
Operating distance	[mm]	0...3.25
Accuracy / deviations		
Correction factor		steel: 1 / stainless steel: 0.7 / brass: 0.4 / aluminium: 0.3 / copper: 0.2
Hysteresis	[% of Sr]	3...15
Switch point drift	[% of Sr]	-10...10
Operating conditions		
Ambient temperature	[°C]	-25...80
Protection		IP 67
Tests / approvals		
EMC		EN 60947-5-2
		EN 55011 class B
MTTF	[years]	502
Mechanical data		
Weight	[g]	90.5
Housing		rectangular
Mounting		non-flush mountable
Materials		stainless steel (1.4305 / 303); PBT
Displays / operating elements		
Display	switching status	2 x LED, red
Electrical connection		
Required protection		miniature fuse to IEC60127-2 sheet 1; ≤ 2 A; fast acting; Place the fuse outside the hazardous area.
Remarks		
Remarks		Recommendation: Check the safe functioning of the unit after a short circuit.
Pack quantity		1 pcs.
Electrical connection - plug		
Connector: 1 x 7/8"		
		

IN0117

Inductive dual sensor for valve actuators

IND2004DAROA/SL/LS-500 RT

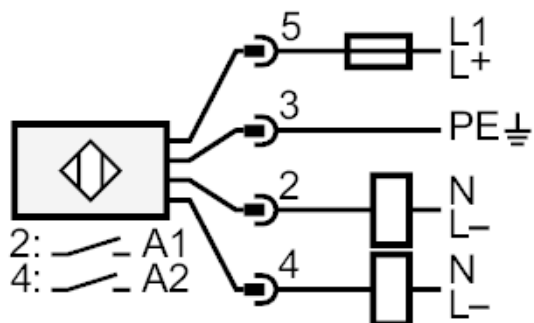

Note miniature fuse to IEC60127-2 sheet 1 \leq 2 A fast acting

Place the fuse outside the hazardous area.