

# IIS700

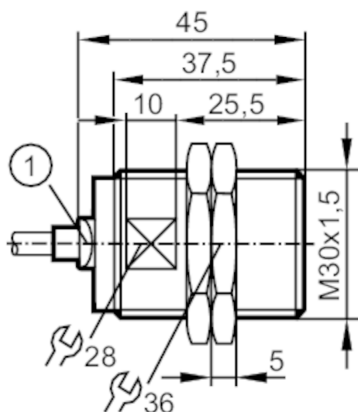

## Inductive sensor

IIB3015BANKG/2M/PUR



1 LED yellow



### Electrical data

Operating voltage [V]	10...30 DC; ("supply class 2" according to UL)
Current consumption [mA]	< 10
Protection class	III
Reverse polarity protection	yes

### Outputs

Electrical design	NPN
Output function	normally open
Max. voltage drop switching output DC [V]	2.5
Permanent current rating of switching output DC [mA]	100
Switching frequency DC [Hz]	100
Short-circuit protection	yes
Overload protection	yes

### Detection zone

Sensing range [mm]	15
Real sensing range $S_r$ [mm]	$15 \pm 10\%$
Operating distance [mm]	0...12.15
Increased sensing range	yes

### Accuracy / deviations

Correction factor	steel: 1 / stainless steel: 0.7 / brass: 0.5 / aluminium: 0.4 / copper: 0.3
Hysteresis [% of $S_r$ ]	3...15
Switch point drift [% of $S_r$ ]	-10...10

### Operating conditions

Ambient temperature [°C]	-40...85
Protection	IP 65; IP 66; IP 67; IP 68; IP 69K

# IIS700



## Inductive sensor

IIB3015BANKG/2M/PUR

Tests / approvals		
EMC	EN 61000-4-2 ESD	4 kV CD / 8 kV AD
	EN 61000-4-3 HF radiated	10 V/m
	EN 61000-4-4 Burst	2 kV
	EN 61000-4-6 HF conducted	10 V
	EN 55011	class B
Vibration resistance	EN 60068-2-6 Fc	20 g (10...3000 Hz) / 50 sweep cycles per frequency; 1 octave per minute in 3 axes
Shock resistance	EN 60068-2-27 Ea	100 g 11 ms half-sine; 3 shocks each in every direction of the 3 coordinate axes
Continuous shock resistance	EN 60068-2-29 Eb	40 g 6 ms; 4000 shocks each in every direction of the 3 coordinate axes
Fast temperature changes	EN 60068-2-14 Na	TA = -40 °C; TB = 85 °C; t1 = 30 min; t2 = < 10 s; 50 cycles
Salt spray test	EN 60068-2-52 Kb	severity level 5 (4 test cycles)
MTTF	[years]	808
UL approval	Ta	-25...75 °C
	Enclosure type	Type 1
	voltage supply	Limited Voltage/Current
	UL Approval no.	A002
	File number UL	E174191
Mechanical data		
Weight	[g]	153.4
Housing		threaded type
Mounting		flush mountable
Dimensions	[mm]	M30 x 1.5 / L = 45
Thread designation		M30 x 1.5
Materials		brass white bronze coated; sensing face: PBT orange; LED window: PEI; lock nuts: brass white bronze coated
Displays / operating elements		
Display	switching status	1 x LED, yellow
Accessories		
Accessories (supplied)		lock nuts: 2 Tooth lock washer: 1, galvanised spring steel
Remarks		
Pack quantity		1 pcs.

# IIS700



## Inductive sensor

IIB3015BANKG/2M/PUR

### Electrical connection

Cable: 2 m, PUR, Ø 4 mm; burning behaviour to ECE R118 rev. 2; 3 x 0.34 mm<sup>2</sup>

### Connection

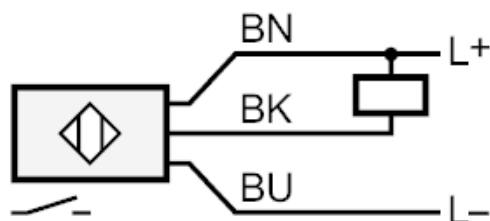

Core colours :

BK = black  
BN = brown  
BU = blue