

EVC675

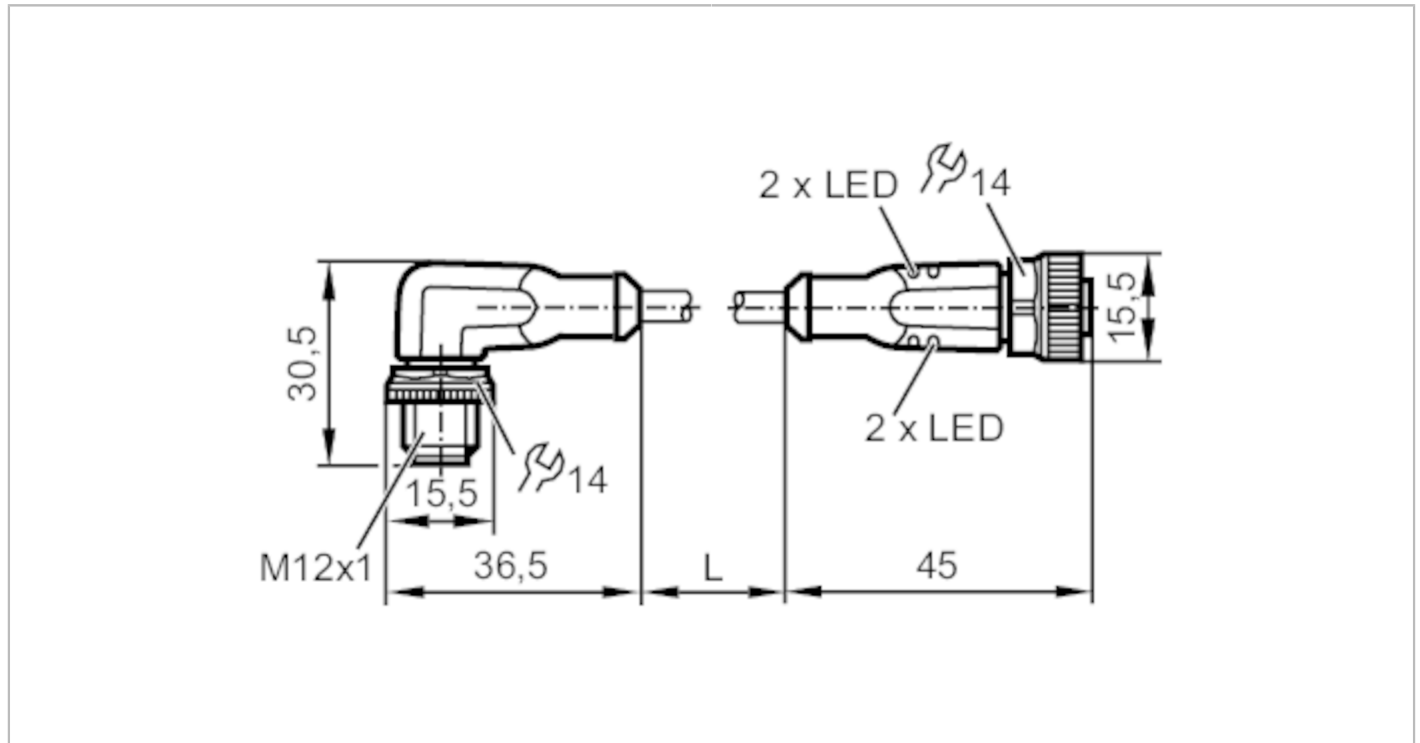

Connection cable

VDOGH034MSS00,3H03STAH030MSS



Application	
Free from silicone	yes
Electrical data	
Operating voltage [V]	10...36 DC
Protection class	II
Max. current load total [A]	4
Outputs	
Electrical design	PNP
Operating conditions	
Ambient temperature [°C]	-25...90
Note on ambient temperature	cULus: ...75 °C
Ambient temperature (moving) [°C]	-25...90
Note on ambient temperature (moving)	cULus: ...75 °C
Protection	IP 65; IP 67; IP 68; IP 69K

EVC675



Connection cable

VDOGH034MSS00,3H03STAH030MSS

Mechanical data		
Weight [g]	41.6	
Materials	connector housing: TPU orange; socket housing: TPU black transparent; Sealing: FKM	
Material nut	brass / brass	
Drag chain suitability	bending radius for flexible use	min. 10 x cable diameter
	travel speed	max. 3.3 m/s for a horizontal travel length of 5 m and max. acceleration of 5 m/s ²
	bending cycles	> 5 Mio.
	torsional strain	± 180 °/m
Drag chain suitability	yes	

Displays / operating elements		
Display	switching status	2 x LED, yellow
	operation	2 x LED, green

Remarks	
Pack quantity	1 pcs.

Electrical connection
Cable: 0.3 m, PUR, Halogen-free, black, Ø 4.9 mm; 3 x 0.34 mm² (42 x Ø 0.1 mm)

Electrical connection - socket

Connector: 1 x M12, straight; Locking: brass, nickel-plated; Contacts: gold-plated; Tightening torque: 0.6...1.5 Nm

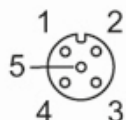

Electrical connection - plug

Connector: 1 x M12, angled; Locking: brass, nickel-plated; Contacts: gold-plated; Tightening torque: 0.6...1.5 Nm



EVC675



Connection cable

VDOGH034MSS00,3H03STAH030MSS

Connection

