

OJE200

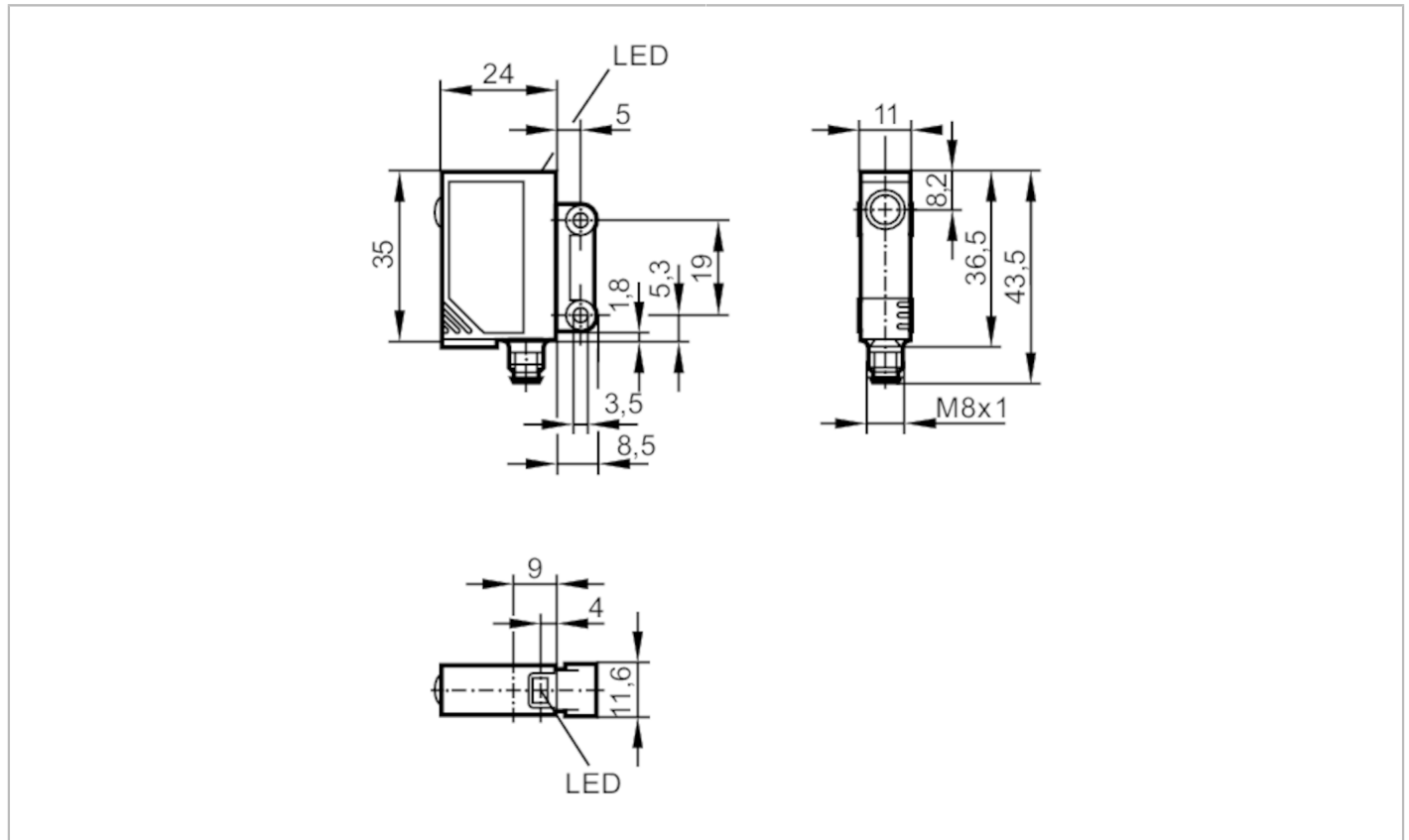

Through-beam sensor receiver

OJE-DPKG/SO/IAS



Application	
Function principle	Through-beam sensor
Electrical data	
Operating voltage [V]	10...30 DC
Current consumption [mA]	< 10
Protection class	III
Reverse polarity protection	yes
Outputs	
Electrical design	PNP
Output function	dark-on mode
Max. voltage drop switching output DC [V]	2.5
Permanent current rating of switching output DC [mA]	200
Switching frequency DC [Hz]	1000
Short-circuit protection	yes
Type of short-circuit protection	pulsed
Overload protection	yes

OJE200



Through-beam sensor receiver

OJE-DPKG/SO/AS

Detection zone		
Transmitter / receiver		receiver
Range [m]		< 10
Range adjustable		no
Operating conditions		
Ambient temperature [°C]		-25...60
Protection		IP 67
Tests / approvals		
EMC	EN 60947-5-2	
MTTF [years]		1152
Mechanical data		
Weight [g]		15
Housing		rectangular
Dimensions [mm]		35 x 11 x 24
Materials		ABS; SEPS
Lens material		PMMA
Lens alignment		side lens
Displays / operating elements		
Display	switching status	1 x LED, yellow
Remarks		
Remarks	operating voltage "supply class 2" according to cULus	
Pack quantity	1 pcs.	
Electrical connection		
Connector: 1 x M8		
		



Through-beam sensor receiver

OJE-DPKG/SO/IAS

Connection

