

OGH301

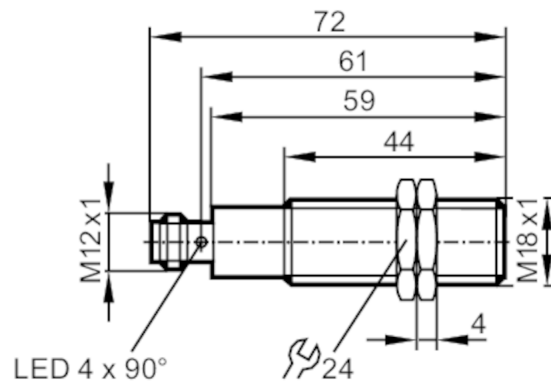

Diffuse reflection sensor with background suppression

OGH-DPKG/US100



transmitter in lower lens
receiver in upper lens



Application

Function principle Diffuse reflection sensor

Electrical data

Operating voltage [V]	10...36 DC
Current consumption [mA]	25
Protection class	II
Reverse polarity protection	yes
Type of light	red light
Wave length [nm]	624

Outputs

Electrical design	PNP
Output function	dark-on mode
Max. voltage drop switching output DC [V]	2.5
Permanent current rating of switching output DC [mA]	150; (200 (...60 °C))
Switching frequency DC [Hz]	1000
Short-circuit protection	yes
Type of short-circuit protection	pulsed
Overload protection	yes

OGH301



Diffuse reflection sensor with background suppression

OGH-DPKG/US100

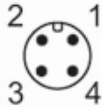
Detection zone		
Range	[mm]	< 100; (white paper 200 x 200 mm 90 % remission)
Range on white object (90 % remission)	[mm]	< 100
Range on grey object (18 % remission)	[mm]	< 100
Range on black object (6 % remission)	[mm]	< 100
Range adjustable		no
Max. light spot diameter	[mm]	9
Light spot dimensions refer to		Range
Background suppression available		yes
Operating conditions		
Ambient temperature	[°C]	-25...80
Protection		IP 67; IP 68; IP 69K
Tests / approvals		
EMC		EN 60947-5-2
MTTF	[years]	372
Mechanical data		
Weight	[g]	59.1
Housing		threaded type
Dimensions	[mm]	M18 x 1 / L = 72
Thread designation		M18 x 1
Materials		housing: stainless steel (1.4404 / 316L); Sealing: EPDM
Lens material		PMMA
Displays / operating elements		
Display	switching status	1 x LED, yellow
Accessories		
Accessories (supplied)		lock nuts: 2 x
Remarks		
Remarks		operating voltage "supply class 2" according to cULus
Pack quantity		1 pcs.
Electrical connection		
Connector: 1 x M12		
		

OGH301



Diffuse reflection sensor with background suppression

OGH-DPKG/US100

Connection

