

E11226

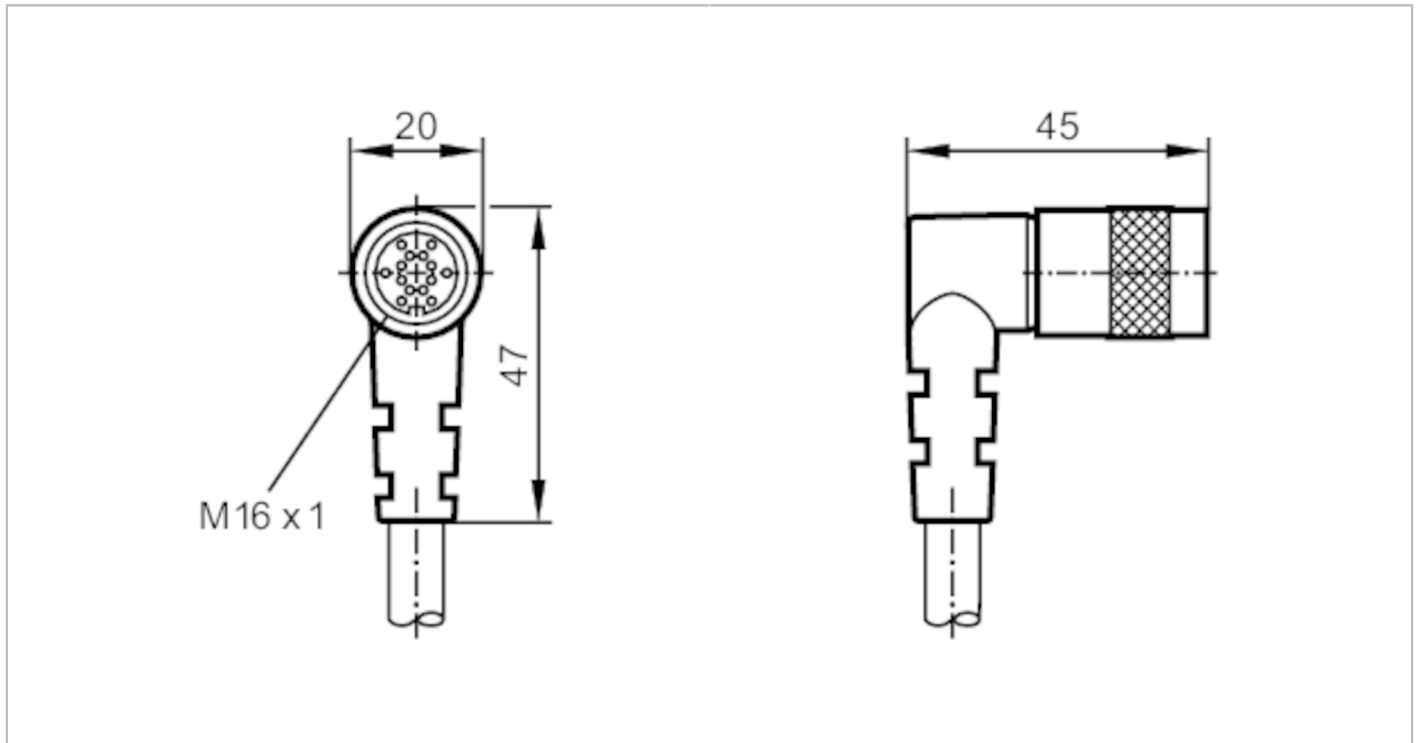

Connecting cable with socket

ADOAO140MSS0005H10



Application		
Free from silicone	yes	
Electrical data		
Operating voltage [V]	< 30 DC	
Max. current load total [A]	3	
Operating conditions		
Ambient temperature [°C]	-25...80	
Protection	IP 67	
Mechanical data		
Weight [g]	565.2	
Dimensions [mm]	45 x 20 x 47	
Materials	PUR	
Material nut	brass	
Drag chain suitability	bending radius for flexible use	min. 12.5 x cable diameter
	travel speed	max. 3.3 m/s for a horizontal travel length of 5 m and max. acceleration of 5 m/s ²
	torsional strain	± 180 °/m
Drag chain suitability	yes	
Remarks		
Pack quantity	1 pcs.	
Electrical connection		
Cable: 5 m, PUR, Halogen-free, black, Ø 9.2 mm; 8 x 0.34 mm ² + 2 x 0.75 mm ²		
Electrical connection - socket		
Connector: 1 x M16, angled; Moulded body: PUR; Locking: brass, nickel-plated		

E11226



Connecting cable with socket

ADAOA140MSS0005H10

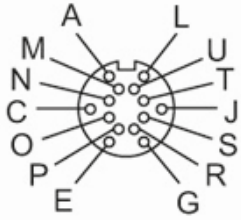

Connection

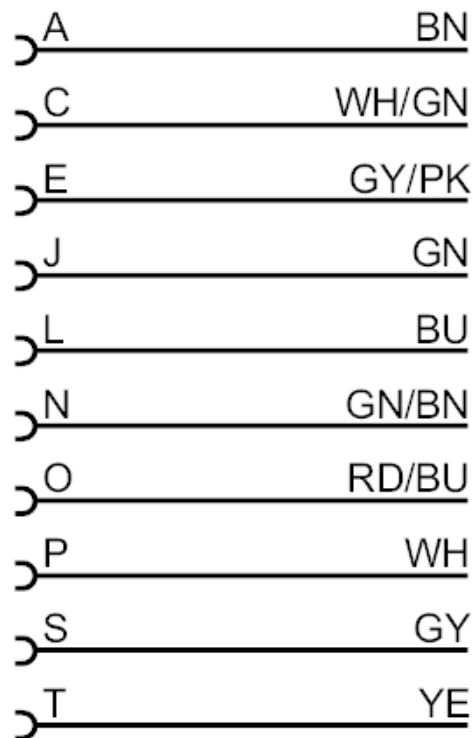

U: not used

R: not used

G: not used

M: not used

Core colours :

BN = brown

BU = blue

GN = green

GY = grey

PK = pink

RD = red

WH = white

YE = yellow